



**EUROPEAN NEW CAR ASSESSMENT PROGRAMME
(Euro NCAP)**

**POLE SIDE IMPACT
TESTING PROTOCOL**

Version 4.2
May 2008

Preface

- Where text is contained within square brackets this denotes that the procedure being discussed is currently being trialled in Euro NCAP. Its incorporation in the Test Protocol will be reviewed at a later date.
- During the test preparation, vehicle manufacturers are encouraged to liaise with the laboratory and to check that they are satisfied with the way cars are set up for testing. Where a manufacturer feels that a particular item should be altered, they should ask the laboratory staff to make any necessary changes. Manufacturers are forbidden from making changes to any parameter that will influence the test, such as dummy positioning, vehicle setting, laboratory environment etc.
- It is the responsibility of the test laboratory to ensure that any requested changes satisfy the requirements of Euro NCAP. Where a disagreement exists between the laboratory and manufacturer, the Euro NCAP secretariat should be informed immediately to pass final judgment. Where the laboratory staff suspect that a manufacturer has interfered with any of the set up, the manufacturer's representative should be warned that they are not allowed to do so themselves. They should also be informed that if another incident occurs, they will be asked to leave the test site.
- Where there is a recurrence of the problem, the manufacturer's representative will be told to leave the test site and the Secretary General should be immediately informed. Any such incident may be reported by the Secretary General to the manufacturer and the person concerned may not be allowed to attend further Euro NCAP tests.

In addition to the settings specified in this protocol, the following information will be required from the manufacturer of the car being tested in order to facilitate the vehicle preparation.

Manufacturer-Specified Settings	
Adjustment	Section Reference
Frontal Impact	
Fuel Tank Capacity	Manufacturer's Handbook
Unladen Kerb Weight	Manufacturer's Handbook
Tyre Pressures	Manufacturer's Handbook
Seat Back/Torso Angle	
95th Percentile Male Seating Position	Section 6.1
Seat Base Tilt	Section 6.1
Child Seat Make/Model	
Door Handle Pull Angle	Section 9.4
Seat belt anchorage position	Section 6.0
Seat Lumbar Support Position	
Engine Running	
Driver Airbag Removal Instructions	
Side Impact	
As Front, in addition:	
Height of non-adjustable version of front seat	Section 5.2
R-Point	Section 1.4

Contents

Page No.

Side Impact Pole Test

1 VEHICLE PREPARATION	6
1.1 Unladen Kerb Mass	6
1.2 Rated cargo and luggage mass	6
1.3 Reference Loads	6
1.4 Impact location	6
1.5 Vehicle Preparation	7
1.6 Vehicle Markings	7
2 DUMMY PREPARATION AND CERTIFICATION	8
2.1 General	8
2.2 Certification	8
2.3 Additions and Modifications to the ES-2 Dummy	8
2.4 Dummy Clothing and Footwear	8
2.5 Dummy Test Condition	8
2.6 Dummy painting	9
2.7 Post Test Dummy Inspection	9
3 INSTRUMENTATION	10
3.1 Dummy Instrumentation	10
3.2 Vehicle Instrumentation	11
3.3 Carrier Instrumentation	11
4 CAMERA LOCATIONS	12
5 PASSENGER COMPARTMENT ADJUSTMENTS	13
5.1 Overview of settings	13
5.2 Determination of and Setting the Fore/aft Position of the Seat.	14
5.3 Setting the Seat Base Tilt and Lumber Positions	14
5.4 Setting the Rear Seats	14
5.5 Setting the Steering Wheel Horizontal Adjustment	14
5.6 Setting the Steering Wheel Vertical Adjustment	15
6 DUMMY POSITIONING AND MEASUREMENTS	16
6.1 Determine the H-point of the driver's seat	17
6.2 Dummy Installation	18
6.3 Dummy Placement	18
6.4 Dummy Positioning Measurements	19
7 STILL PHOTOGRAPHY	21
8 TEST PARAMETERS	22
8.1 Carrier	22
Version 4.1	4
March 2004	

8.2 Pole	22
8.3 Impact Speed	23
8.4 Impact Angle	23
9 AFTER TEST	24
9.1 Door Opening Force	24
9.2 Dummy Removal	24
10 Calculation of Injury Parameters	25
10.1 Head	26
10.2 Ribs	26
10.3 Abdomen	26
10.4 Pelvis	27
10.5 Pubic Symphysis	27

1 VEHICLE PREPARATION

1.1 Unladen Kerb Mass

- 1.1.1 The capacity of the fuel tank will be specified in the manufacturer's booklet. This volume will be referred to throughout as the "fuel tank capacity".
- 1.1.2 Siphon most of the fuel from the tank and then run the car until it has run out of fuel.
- 1.1.3 Refill the tank with fuel, water or other ballast to a mass equivalent to 100% of the tank's capacity of fuel.
- 1.1.4 Check the oil level and top up to its maximum level if necessary. Similarly, top up the levels of all other fluids to their maximum levels if necessary.
- 1.1.5 Ensure that the vehicle has its spare wheel on board along with any tools supplied with the vehicle. Nothing else should be in the car.
- 1.1.6 Ensure that all tyres are inflated according to the manufacturer's instructions for half load.
- 1.1.7 Measure the front and rear axle masses and determine the total mass of the vehicle. The total mass is the 'unladen kerb mass' of the vehicle. Record this mass in the test details.
- 1.1.8 Measure and record the ride heights of the vehicle at all four wheels.

1.2 Rated cargo and luggage mass

- 1.2.1 Calculate the rated cargo and luggage mass as follows: Subtract the measured unladen kerb mass and the rated occupants mass from the maximum permitted laden mass. The rated occupant mass is equal to rated number of occupants times 68 kg. The maximum permitted laden mass can be found on the Manufacturer's Plate, usually in the engine compartment.

1.3 Reference Loads

- 1.3.1 Place both front seats in their mid-positions, this may not be the same. If there is no notch at this position, set the seat in the nearest notch rearward.
- 1.3.2 Place weights equivalent to a ES-2 test dummy (80kg) in the front driver's seating position.
- 1.3.3 Place weights with a mass of the rated cargo and luggage mass or 136kg whichever is less, in the luggage compartment of the vehicle. The normal luggage compartment should be used i.e. rear seats should not be folded to increase the luggage capacity. Spread the weights as evenly as possible over the base of the luggage compartment. If the weights can not be evenly distributed, concentrate weights towards the centre of the compartment.
- 1.3.4 Roll the vehicle back and forth to 'settle' the tyres and suspension with the extra weights on board. Determine the front and rear axle loads of the vehicle. These loads are the "axle reference loads" and the total mass is the "reference mass" of the vehicle.
- 1.3.5 Record the axle reference loads and reference mass in the test details.
- 1.3.6 Measure and record the ride-heights of the vehicle at a point on the wheel arch in the same transverse plane as the wheel centres. Do this for all four wheels.
- 1.3.7 Remove the weights from the luggage compartment and the dummy weights from the front seat.

1.4 Impact location

- 1.4.1 To measure vehicle dimensions and to apply markers, a pointer used to measure co-ordinates in three dimensions will be used.
- 1.4.2 The impact reference line is a line on the striking side of the vehicle, on the exterior of

the vehicle, where a transverse vertical plane passes through the centre of gravity of the head of the dummy seated in accordance with section 6.3.

- 1.4.3 Mark the impact reference line on the side of the vehicle on the exterior, from roof to sill.
- 1.4.4 Using a piece of sticky tape in a colour to contrast with the body-colour, join the points with one edge of the tape. Mark clearly on the tape, which of its edges aligns with the impact reference line. This edge may be used to assess the alignment of the vehicle with the pole.
- 1.4.5 Measure and record the X-distance of the line to the centre of the front wheel axle, or any distinctive reference point.

1.5 Vehicle Preparation

Care should be taken during vehicle preparation that the ignition is not switched on with the battery or any airbag or pretensioner disconnected. This will result in an airbag warning light coming on and the airbag system will need to be reset. Manufacturers will be asked to provide instructions for resetting the airbag so that this may be done 'in-house' in the event that it becomes necessary.

- 1.5.1 Remove the carpeting, spare wheel and any tools or jack from the luggage area. The spare wheel should only be removed if it will not affect the crash performance of the vehicle.
- 1.5.2 Ensure that the vehicle's battery is connected, if possible in its standard position. Check that the dashboard light for the airbag circuit functions as normal.
- 1.5.3 Fit the on-board data acquisition equipment in the boot of the car. Also fit any associated cables, cabling boxes and power sources.
- 1.5.4 Place weights with a mass of approximately the rated cargo and luggage mass in the luggage area.
- 1.5.5 Place weights equivalent to an ES-2 dummy (80 kg) in the front driver's seat of the car (with the front seats in their mid-positions).
- 1.5.6 Weigh the front and rear axle loads of the vehicle. Compare these loads with those determined in Section 1.3.5.
- 1.5.7 The total vehicle mass shall be within 1% of the reference mass (Section 1.3). Each axle load shall be within the smaller of 5% or 20 kg of its respective axle reference load. If the vehicle differs from the requirements given in this paragraph, items may be removed or added to the vehicle which has no influence on its structural crash performance. The levels of ballast in the fuel tank (equivalent in mass to 100% capacity of fuel) may also be adjusted to help achieve the desired axle loads. Any items added to increase the vehicle mass should be securely attached to the car.
- 1.5.8 Repeat Sections 1.5.6 and 1.5.7 until the front and rear axle loads and the total vehicle mass are within the limits set in 1.5.7. Record the final axle loads in the test details.

1.6 Vehicle Markings

- 1.6.1 Euro NCAP markings will be attached to the exterior of the vehicle in the following locations; centre of the bonnet and on the front half of the roof of the vehicle.
- 1.6.2 Test house logos may be added to the vehicle provided that they do not detract attention from the Euro NCAP markings. Suitable locations for such markings would be the middle of the roof and on the bonnet at the base of the windscreen.

2 DUMMY PREPARATION AND CERTIFICATION

2.1 General

- 2.1.1 An ES-2 test dummy shall be used in the front driver's position. It shall conform to the requirements given in document TRANS-WP29-GRSP-2002-11e, which was presented to GRSP on 13th – 17th May 2002 (thirty first session).

2.2 Certification

Full details of the ES-2 certification requirements are available in the document mentioned in Section 2.1.1, TRANS-WP29-GRSP-2002-11e, and the procedures followed are set out in the ES-2 User Manual. No manufacturer shall have access to any pre-test information regarding any of the test equipment to be used by Euro NCAP, or be permitted to influence its selection in any way.

- 2.2.1 The ES-2 dummy should be re-certified after every THREE impact tests.
- 2.2.2 If an injury criterion reaches or exceeds its normally accepted limit (e.g. HIC of 1000) then that part should be re-certified.
- 2.2.3 If any part of the dummy is broken in a test then the part shall be replaced with a fully certified component.
- 2.2.4 A copy of the dummy certification certificate will be provided as part of the full report for a test.

2.3 Additions and Modifications to the ES-2 Dummy

- 2.3.1 None.

2.4 Dummy Clothing and Footwear

- 2.4.1 The dummy will be clothed in an ES-2 rubber 'wet-suit', covering the shoulders, thorax, upper parts of the arms, abdomen and lumbar spine and the upper part of the pelvis. This rubber suit will act as a nominal 'skin' for the dummy torso.
The dummy will be clothed with formfitting, calf-length, cotton stretch pants. Each foot will be equipped with a shoe.

2.5 Dummy Test Condition

2.5.1 Dummy Temperature

- 2.5.1.1 The dummy shall have a stabilised temperature in the range of 18°C to 26°C.
- 2.5.1.2 A stabilised temperature shall be obtained by soaking the dummy in temperatures that are within the range specified above for at least 5 hours prior to the test.
- 2.5.1.3 Measure the temperature of the dummy using a recording electronic thermometer placed inside the dummy's flesh. The temperature should be recorded at intervals not exceeding 10 minutes.
- 2.5.1.4 A printout of the temperature readings is to be supplied as part of the standard output of the test.

2.5.2 Dummy Joints

- 2.5.2.1 Stabilise the dummy temperature by soaking in the required temperature range for at least 5 hours.
- 2.5.2.2 Set the torque on the shoulder screws to obtain a 1-2G holding force of the arm on its pivot.
- 2.5.2.3 For adjustable joints in the legs, the tensioning screw or bolt which acts on the constant friction surfaces should be adjusted until the joint can just hold the adjoining limb in the

horizontal. When a small downwards force is applied and then removed, the limb should continue to fall.

2.5.2.4 The dummy joint stiffnesses should be set as close as possible to the time of the test and, in any case, not more than 24 hours before the test.

2.5.2.5 Maintain the dummy temperature within the range 18 to 26 °C between the time of setting the limbs and up to the time of the test.

2.6 Dummy painting

2.6.1 The dummies should have masking tape placed on the areas to be painted using the size table below. The tape should be completely covered with the following coloured paints. The paint should be applied close to the time of the test to ensure that the paint will still be wet on impact.

ES-2		
Head	Red	100mm square, centreline of head with lower edge at C of G. Only paint outer edge of tape.
Shoulder/Arm	Blue	25mm x 150mm, starting at bottom edge of shoulder fixing hole
Top Rib	Red	150mm strip, starting at the rearmost accessible point at seat back
Mid Rib	Yellow	150mm strip, starting at the rearmost accessible point at seat back
Bottom Rib	Green	150mm strip, starting at the rearmost accessible point at seat back
Abdomen	Red	50mm square
Pelvis	Orange	50mm x 100mm, centred on hip joint point.

NOTE: The tape should be completely covered with the coloured paints specified.

2.7 Post Test Dummy Inspection

2.7.1 The dummy should be visually inspected immediately after the test. Any lacerations of the skin or breakages of the dummy should be noted in the test details. The dummy may have to be re-certified in this case. Refer to Section 2.2.

3 INSTRUMENTATION

All instrumentation shall be calibrated before the test programme. The Channel Amplitude Class (CAC) for each transducer shall be chosen to cover the Minimum Amplitude listed in the table. In order to retain sensitivity, CAC's which are orders of magnitude greater than the Minimum Amplitude should not be used. A transducer shall be re-calibrated if it reaches its CAC during any test. All instrumentation shall be re-calibrated after one year, regardless of the number of tests for which it has been used. A list of instrumentation along with calibration dates should be supplied as part of the standard results of the test. The transducers are mounted according to procedures laid out in SAE J211. The sign convention used for configuring the transducers is stated in SAE J211 (1995).

3.1 Dummy Instrumentation

The ES-2 dummy to be used shall be instrumented to record the channels listed below.

Location	Parameter	Minimum Amplitude	No of channels
Head	Accelerations, $A_x A_y A_z$	250g	3
Shoulder	Forces, $F_x F_y F_z$	8kN	3
Thorax T1	Accelerations, $A_x A_y A_z$	200g	3
Thorax T12	Acceleration, A_y	200g	1
Ribs - Upper Middle Lower	Acceleration, A_y	700g	3
	Deflection, D_{rib}	90mm	3
Abdomen - Front Middle Rear	Forces, F_y	5kN	3
Backplate	Forces, $F_x F_y$	5kN	4
	Moments, $M_y M_z$	200Nm	
T12	Forces, $F_x F_y$	5kN	4
	Moments, $M_x M_y$	300Nm	
Pelvis	Accelerations, $A_x A_y A_z$	150g	3
Pubic Symphysis	Force, F_y	20kN	1
Femurs (L & R)	Forces, $F_x F_y F_z$	22kN	6

	Moments, M_x M_y M_z	350Nm	6
	Total Channels per Dummy		43
	1 x ES-2		43

3.2 Vehicle Instrumentation

- 3.2.1 The vehicle is to be fitted with an accelerometer on the unstruck B-post. The accelerometer is to be fitted in the lateral direction (A_y).
- 3.2.2 Remove carpet and the necessary interior trim to gain access to the sill directly below the B-post.
- 3.2.3 Securely attach a mounting plate for the accelerometer horizontally on to the sill.
- 3.2.4 Fix the accelerometer to the mounting plate. Ensure the accelerometer is horizontal to a tolerance of ± 5 degrees.

VEHICLE

Location	Parameter	Minimum Amplitude	No of channels
B-Post (unstruck)	Acceleration, A_y	350g	1
	Total Channels per Vehicle		1

3.3 Carrier Instrumentation

- 3.3.1 The carrier is to be fitted with an accelerometer at its structure at the centre line, near the centre of gravity. The accelerometer is to be fitted in the direction of movement (A_x).

CARRIER

Location	Parameter	Minimum Amplitude	No of channels
Carrier C of G	Acceleration, A_x	350g	1
	Total Channels per Carrier		1

TOTAL CHANNELS

1x Driver ES-2	43
1x Vehicle	1
1x Carrier	1
TOTAL	45

4 CAMERA LOCATIONS

Set up high speed film cameras according to the following diagrams.

Camera No.	Camera Type	Shot Content
1	>/= 400 fps high speed cine	Front view of vehicle and carrier (wide)
2	>/= 50 fps stills camera	Front view of vehicle and carrier (wide)
3	>/= 50 fps stills camera	Backup for 2 (optional)
4	>/= 400 fps high speed cine	Rear view of vehicle and carrier (wide)
5	>/= 400 fps high speed cine	Plan view of car and carrier (wide)
6	>/= 1000 fps high speed cine	Front view of driver head (impact area) (tight)
7	>/= 1000 fps high speed cine	Front angled view of driver rib and abdomen area (tight)
8	>/= 400 fps high speed cine	30° Side view from front on impact area (wide)

Lens sizes should be chosen appropriately in order to achieve the required shot content/intention. In order to prevent view distortion, a minimum lens size of 9 mm is applicable.

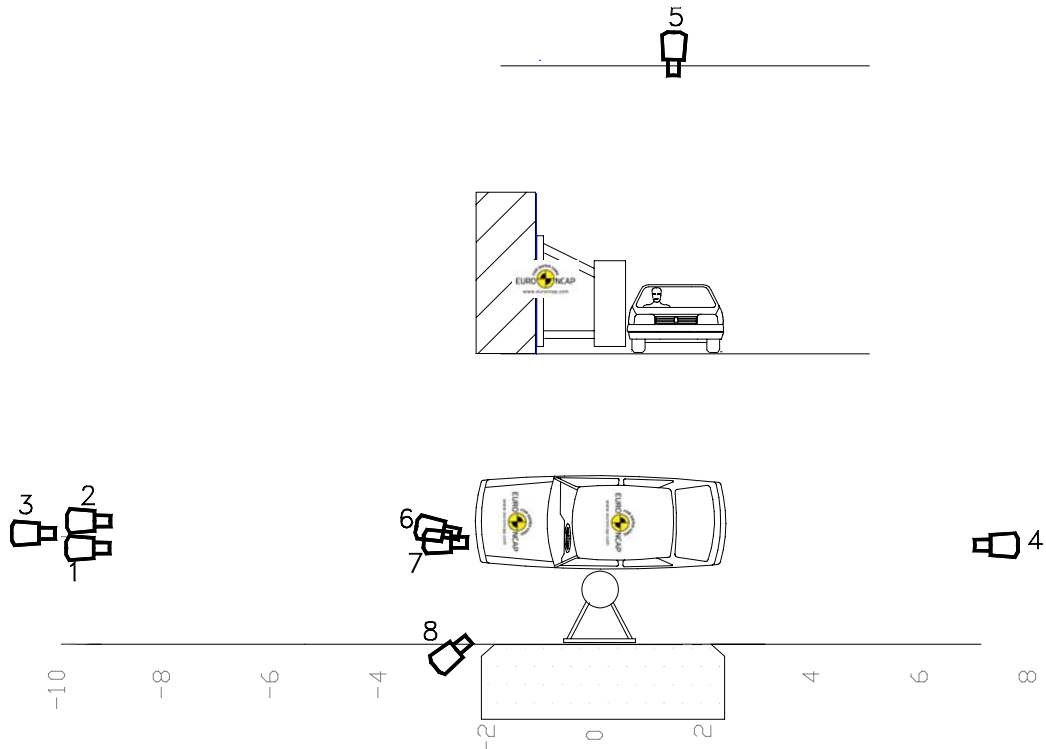

5 PASSENGER COMPARTMENT ADJUSTMENTS

5.1 Overview of settings

Adjustment	Required Setting	Notes	Methods
Seat Fore/Aft	Mid position as defined in section 5.2	Set to first notch rearwards of mid position if not lockable at mid position	See Section 5.2
Seat Base Tilt	Manufacturer's design riding position	Permissible Up to mid position	See Section 5.3
Seat Height	Lowest position		
Seat Back Angle (as defined by torso angle)	Initially set to manufacturer's design riding position	Otherwise initially 25° to Vertical	See Section 6.1
Seat Lumbar Support	Fully retracted		See section 5.3
Front Head Restraints	Highest position		
Rear Head Restraints	Remove or Lowest	Unless instructed otherwise by the manufacturer	
Head Restraint Tilt Angle	Manufacturer's design riding position	Otherwise mid position	
Arm-rests (Front seats)	Lowered position	May be left up if dummy positioning does not allow lowering	
Rear Seat Fore/Aft and seat back angle	Manufacturer's design riding position	Mid or first notch rearwards of mid position if not lockable at mid position	See Section 5.4
Rear Seat Facing	Forward		See Section 5.4
Rear seats arm-rests	Stowed position		
Doors	Closed, not locked		
Roof	Raised	Where applicable	
Glazing	Movable windows and vents in fully opened position		
Steering wheel – horizontal	Mid position		See Section 5.5
Steering wheel – vertical	Mid position		See Section 5.6
Sunroof	Fully closed		
Gear change lever	In the neutral position		
Parking Brake	Disengaged		
Pedals	Normal position of rest		
Sun Visors	Stowed position		
Rear view mirror	Normal position of use		
Seat belt anchorage (where adjustable)	Same position as that used in the side impact		

Adjustments not listed will be set to mid-positions or nearest positions rearward, lower or outboard.

5.2 Determination of and Setting the Fore/aft Position of the Seat.

- 5.2.1 Place a mark on the moving part of seat runner close to the unmoving seat guide.
- 5.2.2 Move the seat to its most forward position of travel.
- 5.2.3 Mark the unmoving seat guide in line with the mark on the seat runner. This corresponds to the seat in its most forward position.
- 5.2.4 Move the seat to the most rearward position of its travel.
- 5.2.5 Mark the unmoving seat guide in line with the mark on the seat runner. This corresponds to the most rearward seating position.
- 5.2.6 Measure the distance between the forwards and rearwards marks. Place a third mark on the seat guide mid-way between the forwards and rearwards marks.
- 5.2.7 Move the seat so that the mark on the seat runner aligns with the mark on the seat guide.
- 5.2.8 Lock the seat at this position. Ensure that the seat is fully latched in its runners on both sides of the seat. The seat is now defined as being at its 'mid seating position'. The vehicle will be tested with the seat in this position.
- 5.2.9 If the seat will not lock in this position, move the seat to the first locking position that is rear of the mid seating position. The vehicle will be tested with the seat in this position.

5.3 Setting the Seat Base Tilt and Lumber Positions

- 5.3.1 If the seat base is adjustable for tilt it may be set to any angle from the flattest to its mid position according to the manufacturer's preference. The same seat tilt setting must be used for frontal and Pole Impact.
- 5.3.2 Seat Lumber Setting. If the seat back is adjustable for lumber support it should be set to the fully retracted position.

The settings for the passenger seat should be as near as possible to being the same as that of the driver's seat.

5.4 Setting the Rear Seats

- 5.4.1 If the rear seat back or cushion is adjustable, put it in the manufacturer's design riding position. If the direction of the seat is adjustable it should be set to face forward, with its axis parallel to the fore/aft direction of the vehicle.

5.5 Setting the Steering Wheel Horizontal Adjustment

- 5.5.1 Choose a part of the fascia that is adjacent to the steering column and can be used as a reference.
- 5.5.2 Move the steering wheel to the most forward position of its travel.
- 5.5.3 Mark the steering column in line with an unmoving part of the fascia. This corresponds to the most forward travel of the steering wheel.
- 5.5.4 Move the steering wheel to the most rearwards position of its travel.
- 5.4.5 Mark the steering column in line with an unmoving part of the fascia. This corresponds to the most rearwards travel of the steering wheel.
- 5.4.6 Measure the distance between the forwards and rearwards marks on the steering column. Place a third mark on the steering column mid-way between the forwards and rearwards marks. This corresponds to the centre of travel of the steering wheel.
- 5.4.7 Move the steering wheel so that the mark on the steering column aligns with the fascia.
- 5.4.8 Lock the steering column at this position. The steering wheel is now in its mid-position of travel. The vehicle will be tested with the steering wheel in this position.

5.6 Setting the Steering Wheel Vertical Adjustment

- 5.6.1 A method that is in principle the same as Section 5.5 should be used to find and set the steering wheel vertical adjustment to the mid position. It is unlikely that the same part of the facia used during the setting procedures for the horizontal adjustments could be used for the vertical adjustment. Care should be taken to avoid unintentional adjustment of the horizontal setting during the vertical adjustment procedure.

6 DUMMY POSITIONING AND MEASUREMENTS

The following chapter deals with all aspects of seating the dummy in the vehicle to be tested. A general timetable of the complete procedure is set out below:-

Timetable

	<i>When this is done</i>
1. Determine the H-point of the driver's seat	Before test day
2. Dummy installation (on boards)	Before test day
3. Dummy placement	Test day
4. Dummy positioning	Test day
5. Dummy positioning measurements	Test day - after vehicle has been positioned for test

6.1 Determine the H-point of the driver's seat

The device to be used is the H-point machine as described in SAE J826 July 1995.

If the seat is new and has never been sat upon, a person of mass $75 \pm 10\text{kg}$ should sit on the seat for 1 minute twice to flex the cushions.

The seat shall have been at room temperature and not been loaded for at least 1 hour previous to any installation of the machine.

- 6.1.1 Set the seat back so that the torso of the dummy is as close as possible to the manufacturer's recommendations for normal use. In absence of such recommendations, an angle of 25 degrees towards the rear from vertical will be used.
- 6.1.2 Place a piece of muslin cloth on the seat. Tuck the edge of the cloth into the seat pan/back join, but allow plenty of slack.
- 6.1.3 Place the seat and back assembly of the H-point machine on the seat at the centre line of the seat.
- 6.1.4 Set the thigh and lower leg segment lengths to 401 and 414 mm respectively.
- 6.1.5 Attach lower legs to machine, ensuring that the transverse member of the T-bar is parallel to the ground.
- 6.1.6 Place the right foot on the undepressed accelerator pedal, with the heel as far forwards as allowable. The distance from the centre line of the machine should be noted.
- 6.1.7 Place left foot at equal distance from centre line of machine as the right leg is from centre line. Place the foot flat on the footwell.
- 6.1.8 Apply lower leg and thigh weights.
- 6.1.9 Tilt the back pan forwards to the end stop and draw the machine away from the seatback.
- 6.1.10 Allow the machine to slide back until it is stopped by contacting the seat back.
- 6.1.11 Apply a 10 kg load twice to the back and pan assembly positioned at the intersection of the hip angle intersection to a point just above the thigh bar housing.
- 6.1.12 Return the machine back to the seat back.
- 6.1.13 Install the right and left buttock weights.
- 6.1.14 Apply the torso weights alternately left and right.
- 6.1.15 Tilt the machine back forwards to the end stop and rock the pan by 5 degrees either side of the vertical. The feet are NOT to be restrained during the rocking. After rocking the T-bar should be parallel to the ground.
- 6.1.16 Reposition the feet by lifting the leg and then lowering the leg so that the heel contacts the floor and the sole lies on the undepressed accelerator.
- 6.1.17 Return the machine back to the seat back.
- 6.1.18 Check the lateral spirit level and if necessary apply a lateral force to the top of the machine back, sufficient to level the seat pan of the machine.
- 6.1.19 Adjust the seat back angle to the angle determined in 6.1.1, measured using the spirit level and torso angle gauge of the H-point machine. Ensure that the torso remains in contact with the seat back at all times. Ensure that the machine pan remains level at all times.
- 6.1.20 Measure and record in the test details the position of the H-point relative to some easily identifiable part of the vehicle structure

6.2 Dummy Installation

It is the intention that the dummy should not be left to sit directly on the seat for more than 2 hours prior to the test. It is acceptable for the dummy to be left in the vehicle for a longer period, provided that the dummy is not left in overnight or for a similarly lengthy period.

If it is known that the dummy will be in the vehicle for a time longer than 2 hours, then the dummy should be sat on plywood boards placed over the seat. This should eliminate unrealistic compression of the seat.

6.3 Dummy Placement

6.3.1 *H-point*

Note that the H-point of the ES-2 dummy is situated 21mm forward of that of the H-point determined by the H-point manikin (Section 6.1). The H-point of the manikin is indicated by 'Hm' on the H-point back plate of the dummy.

6.3.1.1 Position the dummy in the seat, with its back against the seat and its centreline coinciding with the seat centreline.

6.3.1.2 Visually check that the dummy sits square and level in the seat before taking any measurements of the H-point position.

6.3.1.3 Manoeuvre the dummy until its "Hm" position is in a circle with a radius of 10 mm round the H-point of the H-point Manikin as determined in Section 6.1.

6.3.2 *Legs and Feet*

6.3.2.1 Position the left foot perpendicular to the lower leg with its heel on the floorpan in a transverse line with the heel of the right foot.

6.3.2.2 Carefully position the dummy's right foot on the undepressed accelerator pedal with the heel resting as far forward as possible on the floorpan.

6.3.2.3 Measure the separation of the inside surfaces of the dummy's knees and adjust until they are 150 ± 10 mm apart from each other.

6.3.2.4 If possible within these constraints, place the thighs of the dummy on the seat cushion.

6.3.2.5 Check again the position of the H-point, the levelness of the pelvis and the squareness of the dummy in the seat. If everything is in position, set the arms.

6.3.3 *Arms*

The arms of the ES-2 dummy have click-stops corresponding to fixed angles between the torso reference line and the arms.

6.3.3.1 Move both arms of the dummy until they have clicked at those positions corresponding to 40° angle between the arms and the torso reference line.

6.3.4 *Position of the head*

6.3.4.1 Locate the horizontal plane passing through the dummy head centre of gravity. Identify the rearmost point on the dummy head in that plane. Construct a line rearwards in the plane that intersects the front door daylight opening at the same horizontal location and is perpendicular to the longitudinal vehicle centreline. Measure the longitudinal distance between the rearmost point on the dummy head and this line. Refer to the USA Safety Standard FMVSS 201 for the definition of 'door daylight opening'. The door daylight

opening must be measured when the door is closed.

6.3.4.2 If the distance is less than 50mm or the point is not forward of the line, then the seat and/or dummy position shall be adjusted as follows. First, the seat back angle is adjusted, a maximum of 5 degrees, until a 50mm distance is achieved. If this is not sufficient to produce the 50mm distance, the seat is moved forward until the 50mm distance is achieved or until the knees of the dummy contact the dashboard or knee bolster whichever comes first. If the required distance cannot be achieved through movement of the seat, the seatback angle shall be adjusted even further forward until the 50mm distance is obtained or until the seat back is in its full upright locking position.

6.3.5 *Seat belt*

6.3.5.1 Where possible, initially position the upper seat belt anchorage in the manufacturers 50th percentile design position. If no design position is provided, set the adjustable upper seat belt anchorage to the mid-position or nearest notch upward.

6.3.5.2 Carefully place the seat belt across the dummy and lock as normal.

6.3.5.3 Remove the slack from the lap section of the webbing until it is resting gently around the pelvis of the dummy. Only minimal force should be applied to the webbing when removing the slack. The route of the lap belt should be as natural as possible.

6.3.5.4 Place one finger behind the diagonal section of the webbing at the height of the dummy sternum. Pull the webbing away from the chest horizontally forward and allow it to retract in the direction of the D-loop using only the force provided by the retractor mechanism. Repeat this step three times, only.

6.3.5.5 After following the above steps, the seatbelt should lie in a natural position across the dummy sternum and shoulder clavicle. Where this is not the case, for example the belt is close to or in contact with the neck or the belt is above the shoulder rotation adjustment screw, and the upper belt anchorage is adjustable the anchorage should be lowered and steps 6.3.5.3 and 6.3.5.4 repeated.

6.3.5.6 The upper anchorage should be lowered by a sufficient amount to ensure a natural belt position following the repetition of steps 6.3.5.3 and 6.3.5.4 repeated. This may require multiple attempts.

6.3.5.7 Once the belt is positioned the location of the belt should be marked across the dummy chest to ensure that no further adjustments are made. Mark also the belt at the level of the D-loop to be sure that the initial tension is maintained during test preparation.

6.3.5.8 Measure the vertical distance between the dummy nose and the diagonal webbing.

6.3.5.9 Measure the horizontal distance between the diagonal webbing and the door/window.

6.3.6 After positioning the dummy measure and record the dummy position according to Section 6.4 and determine the impact location as described in Section 1.4.

6.4 Dummy Positioning Measurements

The following measurements are to be recorded prior to the test after the dummy settling and positioning procedures have been carried out.

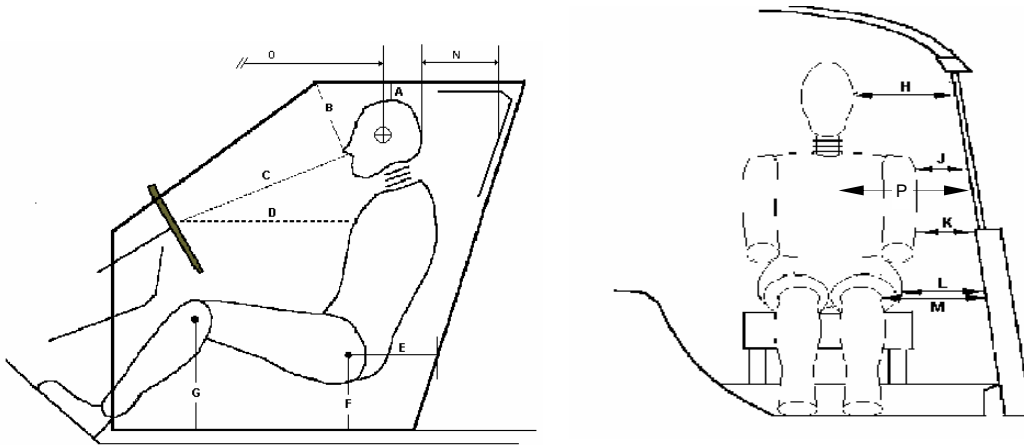

Driver measurements		
A	Head/ roof panel vertical	vertical
B	Nose point / windscreen joint	shortest
C	Nose point / centre of steering	shortest
D	Thorax strap / centre of steering wheel	horizontal
E	Hip joint point / inside opening of the door	horizontal
F	Hip joint point / inside opening of the door	vertical
G	Knee / floor covering	vertical
H	Head / side window pane (or padding)	horizontal
J	Shoulder / window pane (or padding)	horizontal
K	Elbow / door (or padding)	horizontal
L	Pelvis / door (or padding)	horizontal
M	Knee / door (or padding)	horizontal
N	Rearmost point head / daylight opening	horizontal
O	C.o.g. head to front axle	horizontal
P	Belt webbing to door	horizontal

7 STILL PHOTOGRAPHY

The following photographs will be taken pre and post-test unless otherwise indicated. Pre-test photographs will be taken with the dummies in their final positions. All front, rear and side views to be taken at vehicle waist height.

No. View

Car on carrier against pole:

- 1 Top view of full car, carrier and pole.
- 2 Front view of full car, carrier and pole.
- 3 Rear view of full car, carrier and pole.
- 4 Side view of car, carrier and pole at 45 ° to front, impact side.
- 5 Side view of car, carrier and pole at 45 ° to rear, impact side.

Car and carrier away from pole:

- 6 Side view car/carrier impact side, showing full car.
- 7 Side view car/carrier non-impact side, showing full car.
- 8 *To show position of all door latches and/or open doors.
- 9 ^ Side view through open driver's door on driver & seat to show driver compartment and position of seat relative to the sill.
- 10 ^ Detail view on driver's legs and feet through open door.
- 11 Side view through open front passenger door to show driver.
- 12 Side view of car/carrier impact side centred on impact line showing front door and B-post
- 13 ^ Front/side view of pole.
- 14 * Front view of dummy through front windscreen.
- 15 * Inside car view on abdomen/pelvis area.

^ = Pre test only, * = Post test only.

After Dummy Removal

- 16 * Detail view(s) on paint marks on the driver's door and seat

8 TEST PARAMETERS

An on-board data acquisition unit will be used. This equipment will be triggered by a contact plate at the point of first contact ($t=0$) and will record digital information at a sample rate of 20kHz (alternatively a sample rate of 10 kHz may be used). The equipment conforms to SAE J211 (1988).

BEFORE THE TEST, ENSURE THAT THE LIVE BATTERY IS CONNECTED, A SINGLE KEY IS IN THE IGNITION, THE IGNITION IS ON AND THAT THE AIRBAG LIGHT ON THE DASHBOARD ILLUMINATES AS NORMAL (WHERE FITTED).

If the vehicle is fitted with a suspension system, pedal retraction system or any other system which requires running of the engine just before test execution, the engine should be run for a predetermined time, specified by the manufacturer.

8.1 Carrier

A carrier should be used which has a horizontal flat surface with a sufficiently large area to allow unobstructive longitudinal displacement of the vehicle of about 1000mm and rotation of the vehicle during the deformation phase of the impact.

To minimise effects of friction between the tires of the test vehicle and the surface of the carrier this friction is reduced to a minimum by placing the vehicle with each tyre on two sheets of PTFE.

To avoid vehicle movement prior to the impact, the vehicle may be fixed to the carrier until 5 m before the point of impact. The impact speed should be reached 10m before the point of impact. Crumple tubes or a comparable device will decelerate the carrier not earlier than 100ms after the moment / point of impact.

The carrier may be fitted with an emergency abort system. This is optional, the test facility may elect to test without an abort system.

8.1.1 Position the vehicle on the carrier to achieve that the impact reference line is aligned with the centre line of the rigid pole.

8.1.2 The horizontal impact accuracy should be ± 38 mm.

8.2 Pole

The rigid pole is a vertical metal structure beginning no more than 102mm above the lowest point of the tires on the striking side of the test vehicle when the vehicle is loaded as specified in Section 1 and extending at least 100 mm above the highest point of the roof of the test vehicle. The pole is 254 ± 3 mm in diameter and set off from any mounting surface, such as a barrier or other structure, so that the vehicle will not contact such a mount or support at any time within 100ms of the initiation of the vehicle to pole contact.

8.2.1 Mark a line along the vertical centreline of the pole which may be used to check the alignment of the test vehicle on the carrier.

8.3 Impact Speed

8.3.1 During the acceleration phase of the test, the acceleration of the carrier should not exceed 1.5m/s^2 .

8.3.2 Measure the speed of the vehicle as near as possible to the point of impact. using an infra-red beam intercepting two markers at a measured distance apart.

8.3.3 Record the actual test speed in the test details.

TARGET SPEED = $29 \pm 0.5\text{km/h}$

8.4 Impact Angle

8.4.1 The impact angle should be $90^\circ \pm 3^\circ$. Align the vehicle on the carrier so that the angle between the vehicle's longitudinal and the direction of movement of the carrier is 90° .

Where a specified requirement has not been met, Euro NCAP reserves the right to decide whether or not the test will be considered as valid.

9 AFTER TEST

9.1 Door Opening Force

- 9.1.2 Check that none of the doors have locked during the test.
- 9.1.3 Try to open each of the doors on the unstruck side (front door followed by rear door) using a spring-pull attached to the external handle. The opening force should be applied perpendicular to the door, in a horizontal plane, unless this is not possible. The manufacturer may specify a reasonable variation in the angle of the applied force. Gradually increase the force on the spring-pull, up to a maximum of 500N, until the door unlatches. If the door does not open record this then try to unlatch the door using the internal handle. Again attempt to open the door using the spring-pull attached to the external handle. Record the forces required to unlatch the door and to open it to 45° in the test details.
- 9.1.4 If a door does not open with a force of 500N then try the adjacent door on the same side of the vehicle. If this door then opens normally, retry the first door.
- 9.1.5 If the door still does not open, record in the test details whether the door could be opened using extreme hand force or if tools were needed.

Note: In the event that sliding doors are fitted, the force required to open the door sufficiently enough for an adult to escape should be recorded in place of the 45° opening force.

9.2 Dummy Removal

- 9.2.1 Do not move the driver seat. Try to remove the dummy.
- 9.2.2 If the dummy cannot be removed with the seats in its original position, recline the seat back and try again.
- 9.2.3 If the dummy still can not be removed, try to slide the seat back on its runners.
- 9.2.4 If the dummy still can not be removed, the seat can be cut out of the car.

10 Calculation of Injury Parameters

The following table lists all of the channels which are to be measured and the Channel Frequency Class at which they are to be filtered. The injury calculation column lists the parameters which will be calculated for each location. If the injury parameter is not a simple peak value and involves some further calculation, details are given subsequently. Head impacts occurring after the dummy head rebounds from an initial contact are not considered when calculating maximum levels of injury parameters.

Location	Parameter	CFC	Injury Calculation
Head	Accelerations, A_x A_y A_z	1000	HIC Peak acceleration 3msec exceedence (cumulative)
Shoulder	Forces, F_x F_y F_z	600	Peak shoulder forces
Thorax T1	Accelerations, A_x A_y A_z	180	Peak lateral acceleration on T1 and T12
Thorax T12	Acceleration, A_y	180	
Ribs - Upper Middle Lower	Acceleration, A_y	180	Viscous Criterion Peak rib acceleration Peak rib deflection
	Deflection, D_{rib}	180	
Abdomen - Front Middle Rear	Force, F_y	600	Peak of sum of 3 abdomen forces
Backplate	Forces, F_x F_y	600	Peak forces and moments
	Moments, M_y M_z	600	
T12	Forces, F_x F_y	600	Peak forces and moments
	Moments, M_y M_z	600	
Pelvis	Accelerations, A_x A_y A_z	180	Peak lateral acceleration
Pubic Symphysis	Force, F_y	600	Peak Force
Femurs (L & R)	Forces, F_x F_y F_z	600	Peak forces and moments
	Moments, M_x M_y M_z	600	

Using the above channels, dummy injury parameters can be calculated according to the following procedures:

10.1 Head

10.1.1 Calculate the resultant head acceleration A_R from the three components A_x , A_y and A_z after they have been filtered

$$A_R = \sqrt{A_x^2 + A_y^2 + A_z^2}$$

10.1.2 Calculate the Head Injury Criterion (HIC) according to

$$HIC = (t_2 - t_1) \left[\frac{\int_{t_1}^{t_2} A_R \cdot dt}{(t_2 - t_1)} \right]^{2.5}$$

where A_R is expressed in multiples of g. Maximise HIC for any time 'window' ($t_2 - t_1$).

10.1.3 Determine the peak acceleration level of A_R and the level it exceeds for a cumulative time period of three milliseconds i.e. the head 3msec exceedence.

10.2 Ribs

10.2.1 Determine the greatest value of the rib deflection D_{rib} for all three ribs

10.2.2 Calculate the Viscous Criterion according to the equation

$$\text{Viscous Criterion} = V * C$$

$D_{(t)}$ is the instantaneous rib deflection at any time t . $C_{(t)}$ is the compression, related to the rib deflection $D_{(t)}$

$$C_{(t)} = \frac{D_{(t)}}{0.140}$$

V is the velocity of deflection and is calculated as the differential of the deflection with respect to time:

$$V_{(t)} = \frac{8 * [D_{(t+1)} - D_{(t-1)}] - [D_{(t+2)} - D_{(t-2)}]}{12 \delta t}$$

where δt is the time interval between successive digital samples of $D_{(t)}$. Calculate $V * C$ continuously with time and determine its greatest value.

10.3 Abdomen

10.3.1 Find the sum of the three abdomen force transducers as a function of time after the individual components have been filtered.

10.3.2 Determine the maximum value of the total abdominal force.

10.4 Pelvis

10.4.1 Determine the peak lateral acceleration of the pelvis

10.5 Pubic Symphysis

10.5.1 Determine the peak value of the lateral force measured on the pubic symphysis.