

www.euroncap.com

**EUROPEAN NEW CAR ASSESSMENT PROGRAMME
(EuroNCAP)**

**PEDESTRIAN
TESTING PROTOCOL**

Version 4.1
March 2004

**EUROPEAN NEW CAR ASSESSMENT PROGRAM (EuroNCAP)
PEDESTRIAN TESTING PROTOCOL**

Where text is contained within square brackets this denotes that the procedure being discussed is currently being trialed in EuroNCAP. Its incorporation in the Test Protocol will be reviewed at a later date.

In addition to the impact points chosen by EuroNCAP, the following information will be required from the manufacturer of the car being tested before any testing begins.

Manufacturer Nominated Test Zone(s)	
Impactor Type	Notes
Maximum of 3 Bumper Tests	To be nominated by the manufacturer
Maximum of 3 Bonnet Leading Edge Tests	To be nominated by the manufacturer
Maximum of 6 Child Headform Tests	To be nominated by the manufacturer
Maximum of 6 Adult Headform Tests	To be nominated by the manufacturer

Contents

	Page No.
Pedestrian Testing	
1 VEHICLE PREPARATION	6
1.1 Unladen Kerb Weight	6
1.2 Additional Weights	6
1.3 Suspension Settling	6
1.4 Normal Ride Attitude	6
2 VEHICLE MARKING	8
2.1 General	8
2.2 Bumper Reference Lines	8
2.3 Bumper Corners	9
2.4 Bonnet Leading Edge Reference Line	10
2.5 Bonnet Side Reference Line	12
2.6 Corner Reference Point	12
2.7 Bonnet Top	13
2.8 Dividing the Child Headform Zone and Adult Headform Zone into Twelve Equal Width Areas	15
2.9 Labelling the Headform Test Zones	17
2.10 Dividing the Bonnet Leading Edge Reference Line into Sixths	18
2.11 Dividing the Bumper Reference Lines into Sixths	18
2.12 Bumper Lead	19
2.13 Bonnet Leading Edge Height	19
2.14 Labelling the Bonnet Leading Edge and Bumper Test Zones	20
3 DETERMINATION OF IMPACT POINTS	21
3.1 Legform to Bumper Test	21
3.2 Upper Legform to Bumper Test	22
3.3 Upper Legform to Bonnet Leading Edge	23
3.4 Adult and Child Headforms - Structures to be tested	24
3.5 Headform to Bonnet top – Selecting the first point of contact on the vehicle to account for underlying structures.	27
4 RECORDING THE IMPACT POINT LOCATIONS	30
4.1 General	30
4.2 Brief Description of the 3D Measuring Arm	30
4.3 Setting Up 3D Measuring Arm Axes	30
4.4 Digitising Impact Points	31
4.5 Transferring Impact Points to Replacement Vehicle Parts	32
5 PERFORMING OF PEDESTRIAN IMPACT TESTS	33
5.1 General	33
5.2 Propulsion System	33
5.3 Fitting Replacement Parts to Vehicles	33
Version 4.1 March 2004	4

5.4 Photographic Record	33
6 LEGFORM TESTS	34
6.1 Description of Legform and its Instrumentation	34
6.2 Certification	34
6.3 Test Procedure - Pre Test	34
6.4 Test Procedure - Post Test	38
7 UPPER LEGFORM TO BUMPER TESTS	39
7.1 Description of Upper Legform and its Instrumentation	39
7.2 Certification	39
7.3 Test procedure - Pre-test	39
7.4 Test Procedure - Post Test	40
8 UPPER LEGFORM TO BONNET LEADING EDGE TESTS	41
8.1 Description of Upper Legform and its Instrumentation	41
8.2 Certification	41
8.3 Determination of Impact Velocity, Impact Angle and Impact Energy	41
8.4 Test procedure - Pre-test	45
8.5 Test Procedure - Post Test	46
9 HEADFORM TESTING	47
9.1 Description of Headforms and Their Instrumentation	47
9.2 Certification - Dynamic	47
9.3 Test Procedure - Pre Test	47
9.4 Test Procedure - Post Test	48
10 INJURY PARAMETERS	49
10.1 General	49
10.2 Limits	49

1 VEHICLE PREPARATION

1.1 Unladen Kerb Weight

- 1.1.1 The capacity of the fuel tank will be specified in the manufacturer's booklet. This volume will be referred to throughout as the "fuel tank capacity".
- 1.1.2 Syphon most of the fuel from the tank and then run the car until it has run out of fuel.
- 1.1.3 Refill the fuel tank with fuel (or an equivalent mass of water or other ballast) to its fuel tank capacity.
- 1.1.4 Check the oil level and top up to its maximum level if necessary. Similarly, top up the levels of all other fluids to their maximum levels if necessary.
- 1.1.5 Ensure that the vehicle has its spare wheel on board along with any tools supplied with the vehicle. Nothing else should be in the vehicle.
- 1.1.6 Ensure that all tyres are inflated according to the manufacturer's instructions for half load.
- 1.1.7 Remove the front vehicle license plate and its holder/brackets if these are removable from the bumper.
- 1.1.8 Measure the front and rear axle weights and determine the total weight of the vehicle. The total weight is the 'unladen kerb weight' of the vehicle. Record this weight in the test details.

1.2 Additional Weights

- 1.2.1 Put the fore-aft adjustment of both front seats in their mid-positions. If there is no notch at the mid-position, use the first notch immediately rearward.
- 1.2.2 Place a 75kg mass on the driver's seat and a 75kg mass on the front passenger's seat.
- 1.2.3 Ensure that the front wheels are in the straight ahead position.
- 1.2.4 If the suspension is adjustable in any way, ensure that the vehicle is at the correct attitude for travelling at 40km/h.

1.3 Suspension Settling

- 1.3.1 Roll the vehicle forwards by a distance of at least 1 metre
- 1.3.2 Roll the vehicle backwards by a distance of at least 1 metre
- 1.3.3 Repeat steps 1.3.1 and 1.3.2 for three complete cycles. Note: This procedure may be inappropriate for cars which have to be set up as described in 1.2.4.
- 1.3.4 Measure and record the ride heights of the vehicle at the point on the wheel arch in the same transverse plane as the wheel centres. Do this for all four wheels.

1.4 Normal Ride Attitude

- 1.4.1 After following the above procedures the vehicle is in its Normal Ride Attitude when the vehicle attitude is in running order positioned on the ground, with the tyres inflated to the recommended pressures, the front wheels in the straight-ahead position, with maximum capacity of all fluids necessary for operation of the vehicle, with all standard equipment as provided by the vehicle manufacturer, with a 75 kg mass placed on the driver's seat and with a 75 kg mass placed on the front passenger's seat, and with the suspension set for a driving speed of 40 km/h in normal running conditions specified by the manufacturer (especially for vehicles with an active suspension or a device for automatic levelling). The manufacturer shall specify the Normal Ride Attitude with reference to the vertical (Z) position of any marks, holes,

surfaces and identification signs on the vehicle body, above the ground. These marks shall be selected such as to be able to easily check the vehicle front and rear ride heights and vehicle attitude. If the reference marks are found to be within ± 25 mm of the design position in the vertical (Z) axis, then the design position shall be considered to be the normal ride height. If this condition is met, either the vehicle shall be adjusted to the design position, or all further measurements shall be adjusted, and tests performed, to simulate the vehicle being at the design position.

- 1.4.2 All ride heights measured are the Normal Ride Attitude ride heights.

2 VEHICLE MARKING

2.1 General

- 2.1.1 The vehicle shall be marked up as described in the following sections. These marking procedures divide the front and bonnet of the car into zones which are then assessed using appropriate bodyform impactors.
- 2.1.2 After the vehicle's front has been divided up, specific impact locations shall be chosen according to their likelihood of causing injury. Testing will be carried out at those locations considered the most potentially injurious.
- 2.1.3 All markings and measurements should be made with the vehicle in its Normal Ride Attitude.

2.2 Bumper Reference Lines

For vehicles with an identifiable bumper structure the upper Bumper Reference Line is defined as the geometric trace of the upper most points of contact between a straight edge and the bumper, when the straight edge, held parallel to the vertical longitudinal plane of the car and inclined rearwards by 20 degrees, is traversed across the front of the car whilst maintaining contact with the upper edge of the bumper. For a vehicle with no identifiable bumper structure it is defined as the geometric trace of the upper most points of contact between a straight edge 700 mm long and the bumper, when the straight edge, held parallel to the vertical longitudinal plane of the car and inclined rearwards by 20 degrees, is traversed across the front of the car, whilst maintaining contact with the ground and the surface of the bumper. See Figure 2.1a.

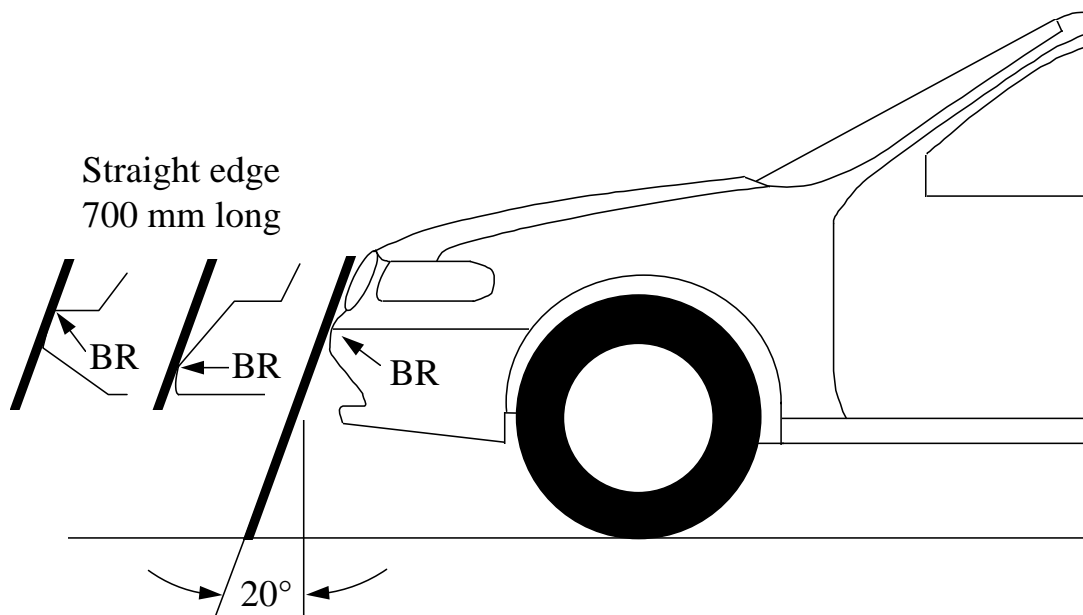

Figure 2.1a
Determination of Upper Bumper Reference Line

- 2.2.1 With a 700mm straight edge fixed at 20° to the vertical and in a plane parallel to the vertical longitudinal plane of the car, position the straight edge at one end of, and in contact with, the bumper and the ground. The straight edge may be shortened to avoid contact with structures above the bumper, the straight edge may also be lengthened to reach the bumper, this is at the test laboratories discretion.
- 2.2.2 Mark the uppermost point of contact of the straight edge and bumper.
- 2.2.3 Pull the straight edge away from the bumper, move it towards the other end of the bumper by not more than 100mm and then into contact with the bumper.
- 2.2.4 Mark the uppermost point of contact of the straight edge and bumper.
- 2.2.5 Repeat Sections 2.2.3 to 2.2.4 along the whole of the length of the bumper.
- 2.2.6 Using a flexible rule, join the marks on the bumper to form a line. This line may not be continuous but may “jump” around the licence plate area etc. This line is the Upper Bumper Reference Line.
- 2.2.7 The Lower Bumper Reference Line also needs to be marked on the vehicle. This line identifies the lower limit to significant points of pedestrian contact with the bumper. It is defined as the geometric trace of the lower most points of contact between a straight edge 700mm long and the bumper, when the straight edge, held parallel to the vertical longitudinal plane of the car and inclined forwards by 25°. It is traversed across the front of the car, while maintaining contact with the ground and with the surface of the bumper, see Figure 2.1b below.
- 2.2.8 Proceed as per sections 2.2.2 to 2.2.6, this line is the Lower Bumper Reference Line.

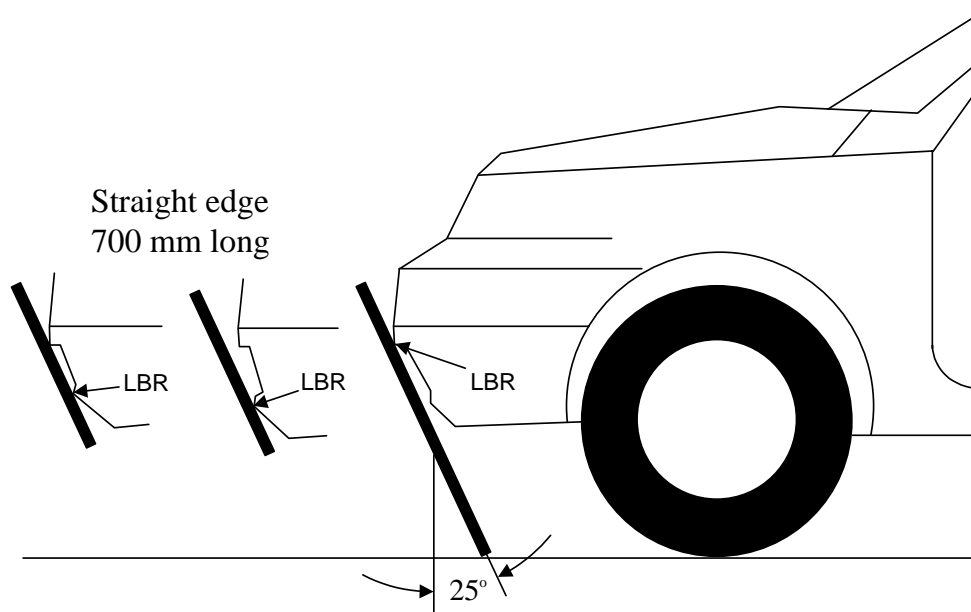

Figure 2.1b
Determination of Lower Bumper Reference Line

2.3 Bumper Corners

The Corner of Bumper is the point of contact of the vehicle with a vertical plane which makes an angle of 60° with the vertical longitudinal plane of the car and is tangential to the

outer surface of the bumper, see Figure 2.2. Where multiple or continuous contacts occur the most outboard contact shall form the bumper corner.

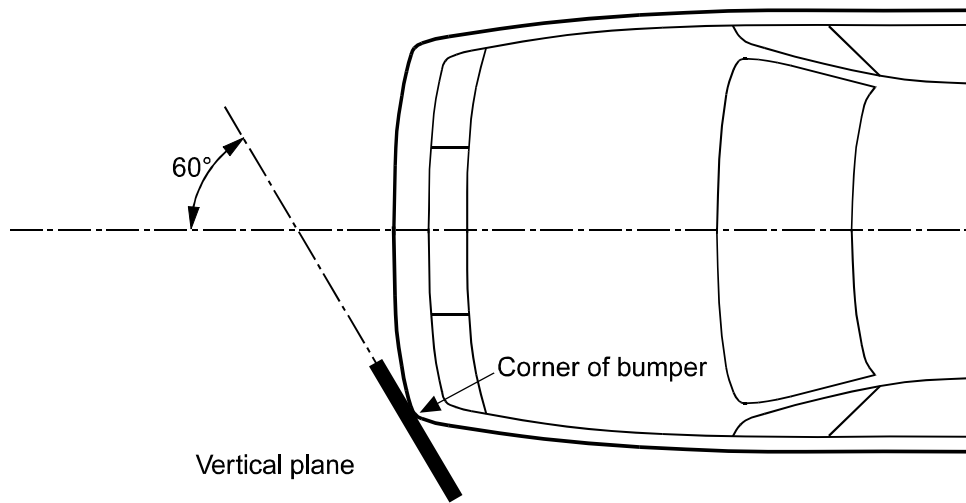

Figure 2.2
Determination of Corner of Bumper

- 2.3.1 Fix a 700mm straight edge at 60° to the longitudinal direction of the car. With this edge horizontal move it into contact with the most forward part of the bumper.
- 2.3.2 Mark the point of contact between the straight edge and the bumper. This is the Bumper Corner.
- 2.3.3 If the bumper is angled at essentially 60°, so that the straight edge makes a continuous contact or multiple contacts rather than a point contact, the outermost point of contact shall be the Bumper Corner.
- 2.3.4 Repeat for the other side of the vehicle.

2.4 Bonnet Leading Edge Reference Line

The Bonnet Leading Edge Reference Line is defined as the geometric trace of the points of contact between a straight edge 1000mm long and the front surface of the bonnet, when the straight edge, held parallel to the vertical longitudinal plane of the car and inclined rearwards by 50° and with the lower end 600mm above the ground, is traversed across and in contact with the bonnet leading edge, see Figure 2.3. For vehicles having the bonnet top surface inclined at essentially 50°, so that the straight edge makes a continuous contact or multiple contacts rather than a point contact, determine the reference line with the straight edge inclined rearwards at an angle of 40°. For vehicles of such shape that the bottom end of the straight edge makes first contact then that contact is taken to be the bonnet leading edge reference line, at that lateral position. For vehicles of such shape that the top end of the straight edge makes first contact then the geometric trace of 1000mm wrap around distance as defined in section 2.7, will be used as the Bonnet Leading Edge reference line at that lateral position. The top edge of the bumper shall also be regarded as the bonnet leading edge, if it is contacted by the straight edge during this procedure.

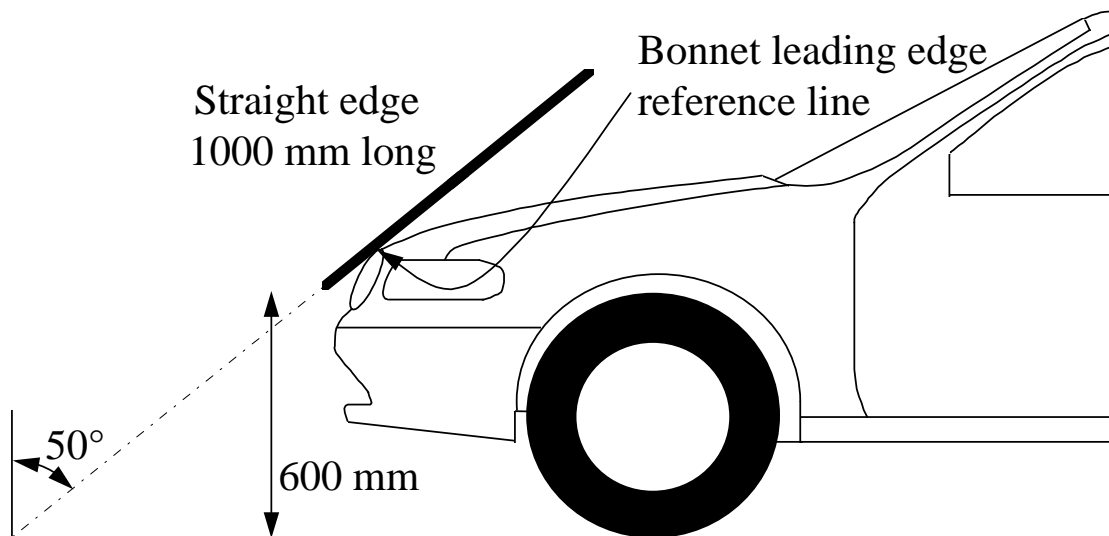

Figure 2.3
Determination of the Bonnet Leading Edge Reference Line

- 2.4.1 The 'bonnet leading edge' is defined as the front upper outer structure including the bonnet and wings, the upper side members of the headlight surround and any other attachments. The reference line identifying the position of the leading edge is defined by its height above ground and by the horizontal distance separating it from the bumper (Bumper Lead), as determined in accordance with sections 2.4, 2.12 and 2.13.
- 2.4.2 Fix a straight edge that is 1000mm long at 50° to the vertical and with its lower end at a height of 600mm. If the top surface of the bonnet is inclined at essentially 50° , so that the straight edge makes a continuous contact or multiple contacts rather than a point contact, determine the reference line with the straight edge inclined rearwards at an angle of 40° . With this edge in a plane parallel to the vertical longitudinal plane of the car, position the straight edge at one end of, and in contact with, the bonnet.
- 2.4.3 Mark the point of contact of the straight edge and bonnet.
- 2.4.4 If the bottom end of the straight edge makes first contact then mark this point of contact.
- 2.4.5 If the top end of the straight edge makes first contact behind the 1000mm Wrap Around Line, then use the geometric trace of the 1000mm Wrap Around Line (see Section 2.7) at that lateral position.
- 2.4.6 Pull the straight edge away from the bonnet, move it towards the other end of the bonnet by not more than 100mm and then into contact with the bonnet.
- 2.4.7 Mark the point of contact of the straight edge and bonnet.
- 2.4.8 Repeat Sections 2.4.4 to 2.4.7 across the whole width of the bonnet. Using a flexible rule, join the marks on the bonnet to form a line. This line may not be continuous but may "jump" around the grill and badge area etc. This line is the Bonnet Leading Edge Reference Line.

2.5 Bonnet Side Reference Line

The Bonnet Side Reference Line is defined as the geometric trace of the highest points of contact between a straight edge 700mm long and the side of a bonnet, as defined in 2.4.1, and A-Pillar, when the straight edge, held parallel to the lateral vertical plane of the car and inclined inwards by 45° is traversed down the side of the bonnet top and A-Pillar, while remaining in contact with the surface of the body shell, any contact with door mirrors is ignored. See Figure 2.4. Where multiple or continuous contacts occur the most outboard contact shall form the bonnet side reference line.

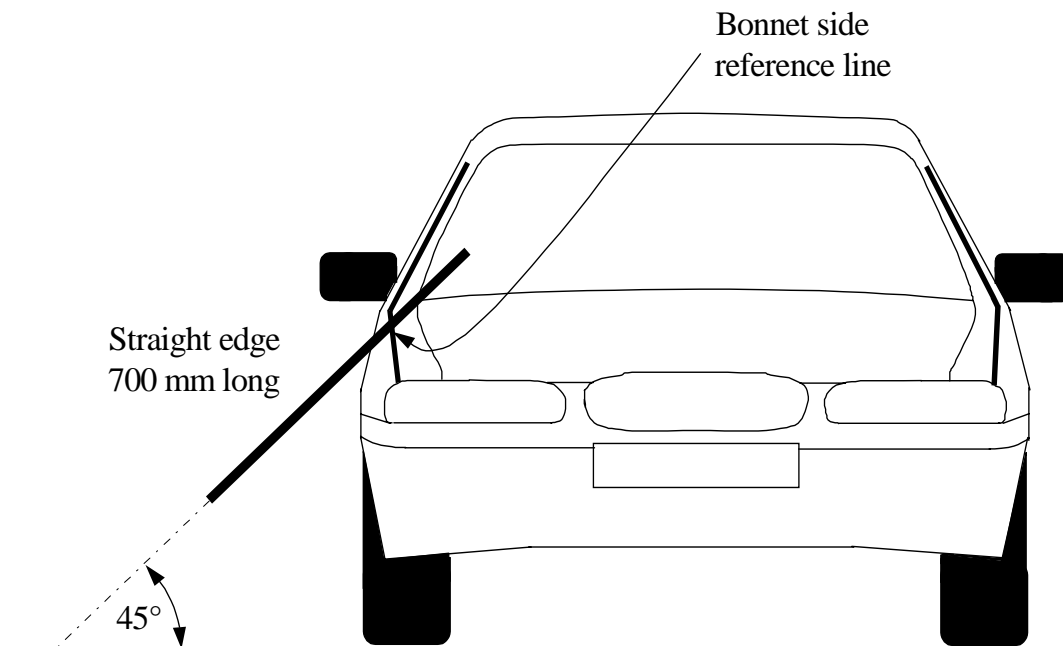

Figure 2.4
Determination of the Bonnet Side Reference Lines

- 2.5.1 Fix a straight edge that is 700mm long at 45° to the vertical. With this edge in a plane parallel to the lateral vertical plane of the car, position the straight edge at one end of the front wing, and in contact with, the bonnet.
- 2.5.2 Proceed as per sections 2.2.2 to 2.2.6, but moving the edge along the length of the wing, A-Pillar and Cant Rail if required (depending of the position of the 2100 Wrap Around Distance).
- 2.5.3 Repeat for the other side of the vehicle.

2.6 Corner Reference Point

The Corner Reference Point is defined as the intersection of the Bonnet Leading Edge Reference Line (Section 2.4) and the Bonnet Side Reference Line (Section 2.5), see Figure 2.5. Where multiple or continuous contacts occur the most outboard contact shall form the corner reference point.

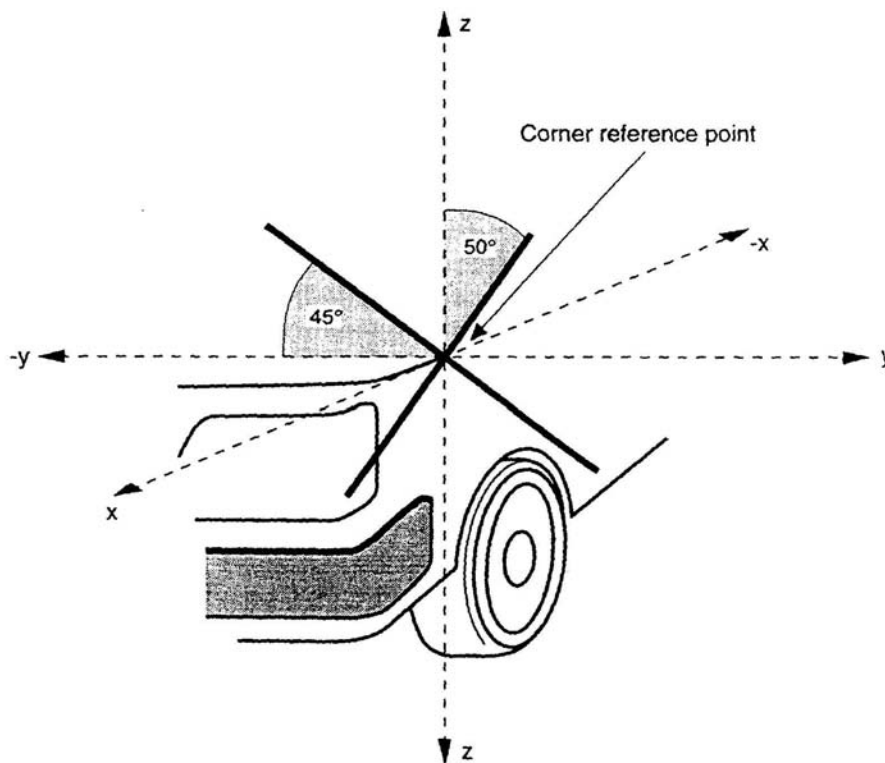

Figure 2.5
Determination of the Corner Reference Point

2.7 Bonnet Top

The Bonnet Top is defined as the outer structure that includes the upper surface of all outer structures except the windscreen, A-pillars and structures further rearwards of them. It includes, but is not limited to the bonnet, wings, scuttle, wiper spindles and lower windscreen frame. It is bounded by the geometric trace of the 1000mm wrap around line in the front, as defined in section 2.7, the Bonnet Side Reference Lines, as defined in section 2.5, and the base of the windscreen.

Mark on the bonnet top, windscreen, A-pillars or roof (depending on the size and shape of the vehicle being tested) the 1000mm, 1250mm, 1500mm, 1800mm and 2100mm Wrap Around Lines. These are the geometric traces described on the top of the bonnet by the end of flexible tape or wire 1000, 1250, 1500, 1800 or 2100mm long, when it is held in a vertical fore/aft plane of the car and traversed across the front of the bonnet and bumper. The tape should be held taut throughout the operation with one end held in contact with the ground, vertically below the front face of the bumper and the other end held in contact with the bonnet top, windscreen, A-pillars or roof, see Figure 2.6.

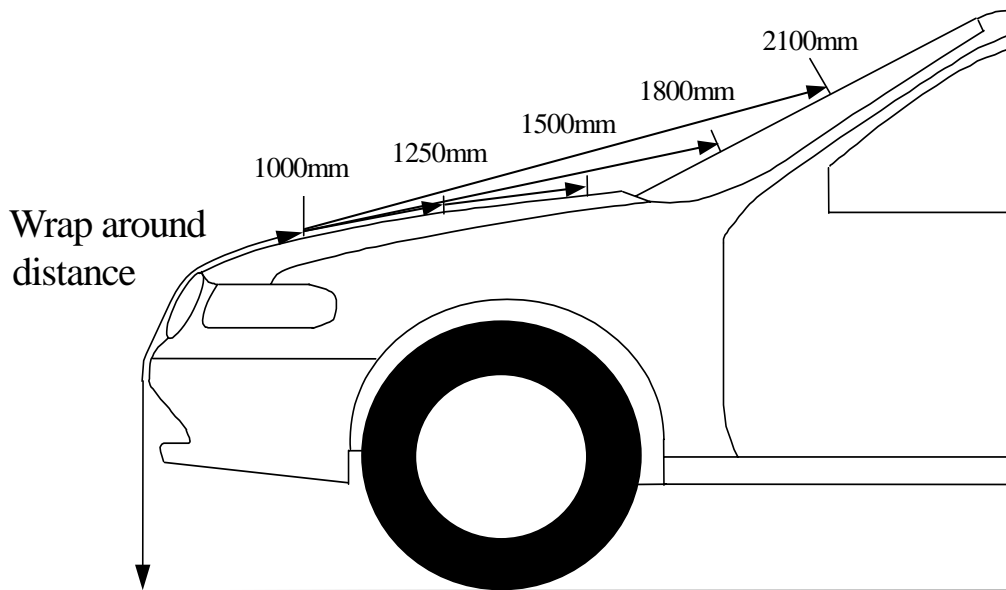

Figure 2.6
Determination of wrap around lines

- 2.7.1 Begin at one end of the bumper adjacent to the Bumper Corner.
- 2.7.2 Place the end of a flexible tape measure or graduated wire on the floor vertically below the front edge of the bumper.
- 2.7.3 Wrap the tape (or wire) over the bumper and bonnet ensuring that it is maintained in a vertical longitudinal plane and that its end is still in contact with the ground, see Figure 2.6.
- 2.7.4 Mark on the bonnet top, windscreen, A-pillars or roof the Wrap Around Lines of 1000mm, 1250mm, 1500mm, 1800mm and 2100mm. Where any of the WAD's lie below the outer contour of the vehicle, for example in the gap behind the bonnet, using the tape (or wire) approximate the outer contour of the vehicle and project the WAD vertically down onto the underlying structure.
- 2.7.5 Reposition the end of the tape on the ground no further than 100mm towards the other side of the bumper.
- 2.7.6 Repeat steps 2.7.2 to 2.7.5 until the width of the vehicle has been marked up to the Side Reference Lines, see Section 2.5.
- 2.7.7 Join the points marked on the bonnet to form continuous lines at wrap around distances of 1000mm, 1250mm, 1500mm, 1800mm and 2100mm. The region between 1000 and 1500mm corresponds to the child headform zone. The region between 1500 and 2100mm corresponds to the adult headform zone, See Figure 2.7.

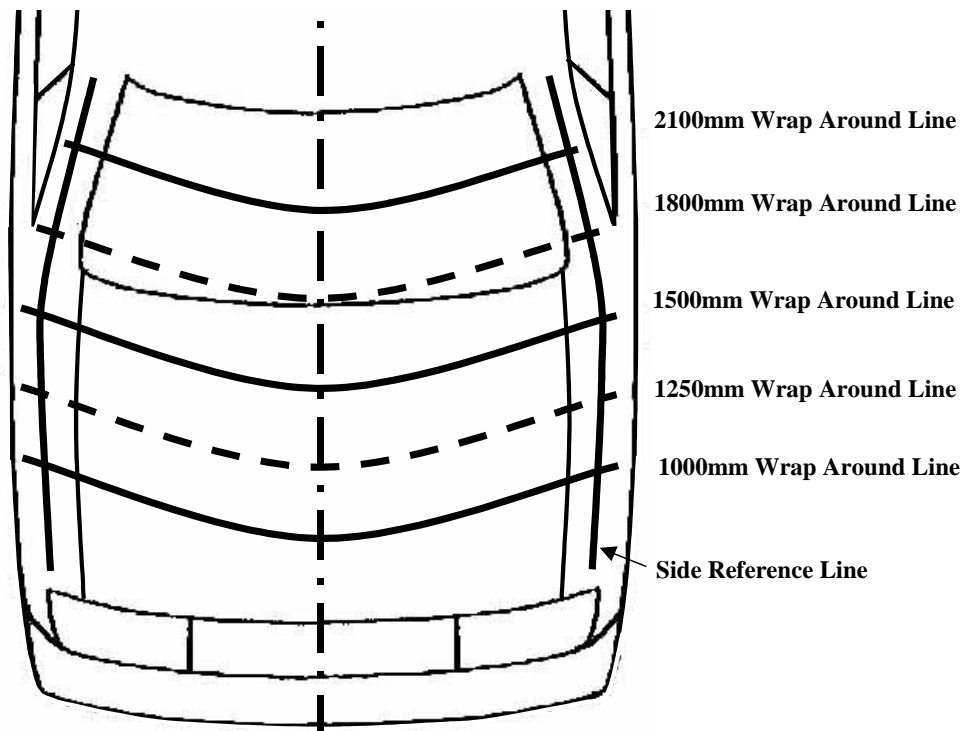

Figure 2.7
1000mm-2100mm Wrap Around Lines

2.8 Dividing the Child Headform Zone and Adult Headform Zone into Twelve Equal Width Areas

- 2.8.1 Begin with the 1000mm wrap around distance.
- 2.8.2 Using a flexible tape, starting at the intersections of the 1000mm Wrap Around Line and the Side Reference Lines. Measure the distance from one Side Reference Line to the other, along the outer contour of the bonnet (measure directly between the Side Reference Lines and not along the 1000mm bonnet wrap-around line). Record this distance in the test details.
- 2.8.3 Calculate 1/12 of this distance and mark the 1/12 points with the tape between the Side Reference Lines in accordance with 2.8.2, and around the outer contour of the vehicle.
- 2.8.4 Using a flexible tape, measure the distance from one Side Reference Line to the other, parallel to the lateral axis of the vehicle, placing the tape at the furthest forward point along the 1000 wrap-around line (again, measure directly between the Side Reference Lines and not along the 1000mm Wrap Around Line). Record this distance in the test details. In cases where the furthest forward point of the 1000mm WAD is forward of the corner reference points, project each point measured in 2.8.2 forward, parallel to the longitudinal axis of the vehicle, onto the 1000mm WAD and proceed to 2.8.6.
- 2.8.5 Calculate 1/12 of this distance and mark the 1/12 points with the tape between the Side Reference Lines as for 2.8.4 and along the outer contour of the vehicle.
- 2.8.6 Join the 1/12 points from the two measured lines, which now intersect with the 1000mm wrap around distance line. Mark each intersection with the 1000mm wrap around line. See Figure 2.8a.

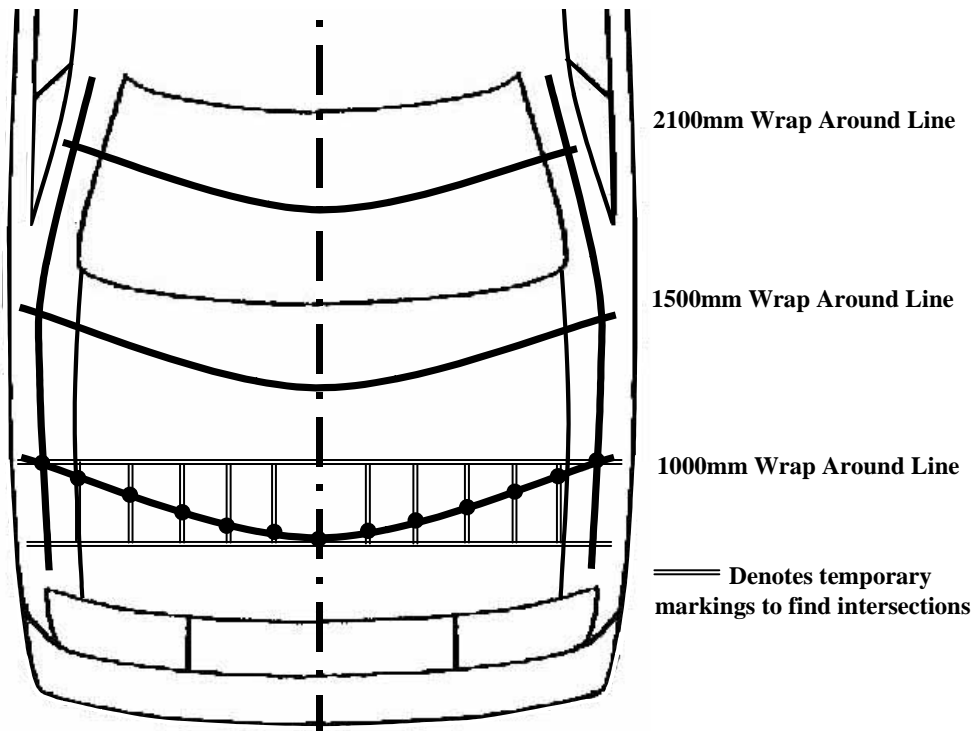

Figure 2.8a
Division of the 1000mm Wrap Around Line into twelve

- 2.8.7 Repeat steps 2.8.2 to 2.8.6 for the 1500mm and 2100mm wrap-around lines
- 2.8.8 Join up the respective 1/12 intersection marks of the 1000mm wrap around line with the 1500mm wrap around line.
- 2.8.9 Join up the respective 1/12 intersection marks of the 1500mm wrap around line with the 2100mm wrap around line. See Figure 2.9.
- 2.8.10 If there are 'steps' in the Side Reference Lines, for example caused by wheel arch body trim, the intersections may not be parallel with each other, see Figure 2.8b.

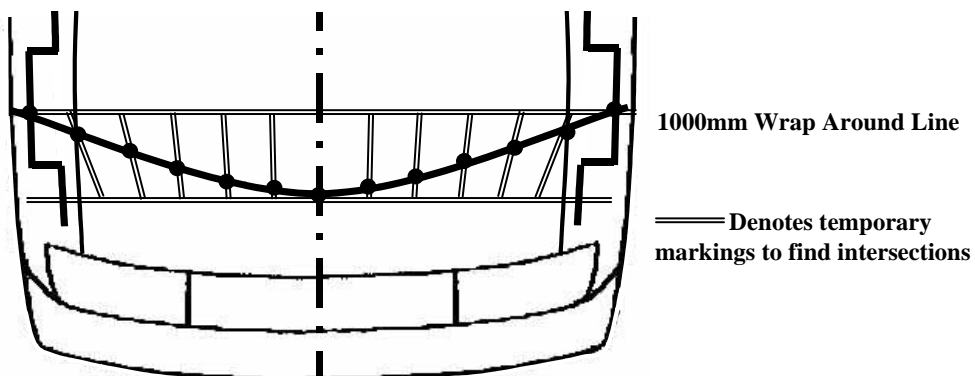

Figure 2.8b
Division of the 1000mm Wrap Around Line into twelve

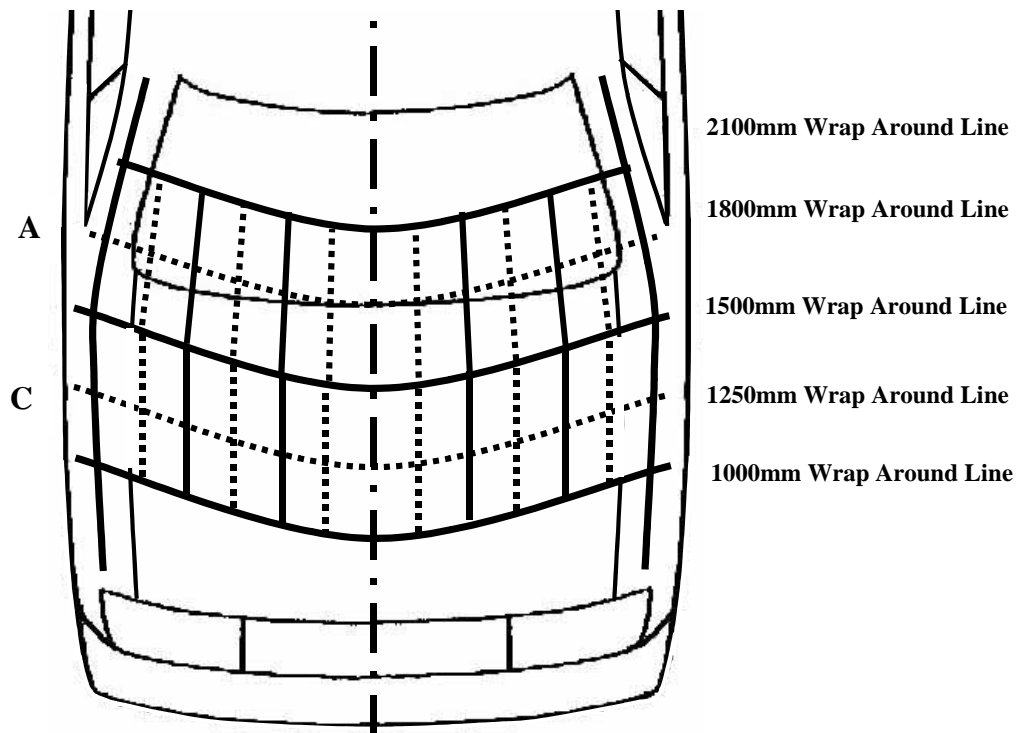

Figure 2.9
Division of the headform test zones

NOTES:

The combination of splitting the headform areas laterally into twelve equal width areas and dividing the child and adult zones longitudinally by using wrap-around distances of 1250mm and 1800mm results in the vehicle now consisting of the following:

Child headform zone: Six areas (sixths) each consisting of four quarters.

Adult headform zone: Six areas (sixths) each consisting of four quarters.

For an area to be split into quarters, it must be large enough to enable a test to be carried out in any of the remaining quarters (refer to Section 3.4). If this is not possible, halving the area would be allowed, again provided that there was sufficient space to test.

2.9 Labelling the Headform Test Zones

2.9.1 Beginning in the adult headform zone and moving from the right hand side of the vehicle to the left hand side of the vehicle the first sixth (two twelfths) is labeled A1. The remaining sixths are then labeled A2, A3....A6, (A=Adult).

2.9.2 Each sixth has been divided up into four quarters, beginning with the top row of area A1 label from the right hand side of the vehicle to the left hand side of the vehicle alphabetically i.e. A and B, then continue in the lower row i.e. C and D. Repeat this for the remaining sixths.

2.9.3 Repeat steps 2.9.1 and 2.9.2 in the child headform zone replacing A with C (C=Child). See Figure 2.10.

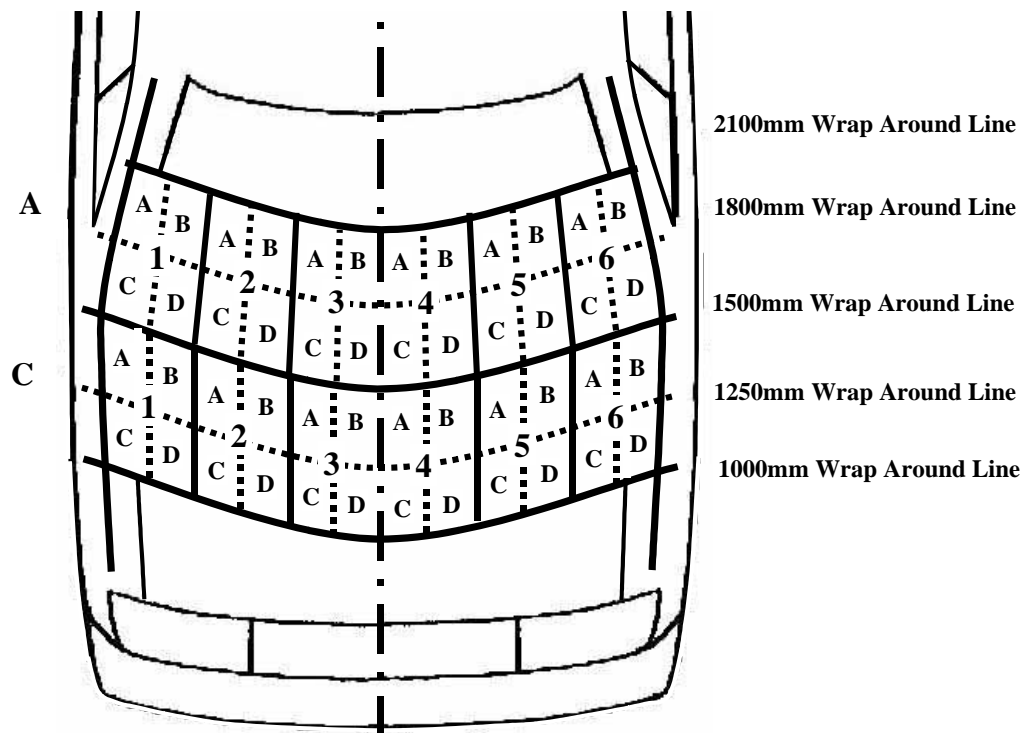

Figure 2.10
Labelling of the headform test zones

2.10 Dividing the Bonnet Leading Edge Reference Line into Sixths

- 2.10.1 Using a flexible tape, measure the distance between the two corner reference points, along the outer contour of the bonnet (measure directly between the corner reference points and not along the Bonnet Leading Edge Reference Line).
- 2.10.2 Divide the measured distance by six and project forward, parallel to the centreline of the vehicle, each point onto the bonnet leading edge. See Figure 2.11.

NOTES:

The division of the bonnet leading edge reference line has resulted in three areas (thirds) across the front of the vehicle, each consisting of two halves.

2.11 Dividing the Bumper Reference Lines into Sixths

- 2.11.1 Place a flexible measuring tape along the horizontal contour of the Upper Bumper Reference Line, ignoring any small discontinuities in the bumper profile, for example licence plate depressions. Using the Bumper Corners as the extreme measuring points, measure and divide the distance by six, see Figure 2.11. If the Bumper Corner is not coincidental with the Upper Bumper Reference Line, then mark a point (Inner Bumper Corner) on the Upper and Lower Bumper Reference Lines at the same lateral distance as the Bumper Corner.
- 2.11.2 Repeat 2.11.1 for the Lower Bumper Reference Line.

NOTES:

The division of the Upper Bumper Reference Line results in three test zones across the front of the vehicle, each consisting of two halves.

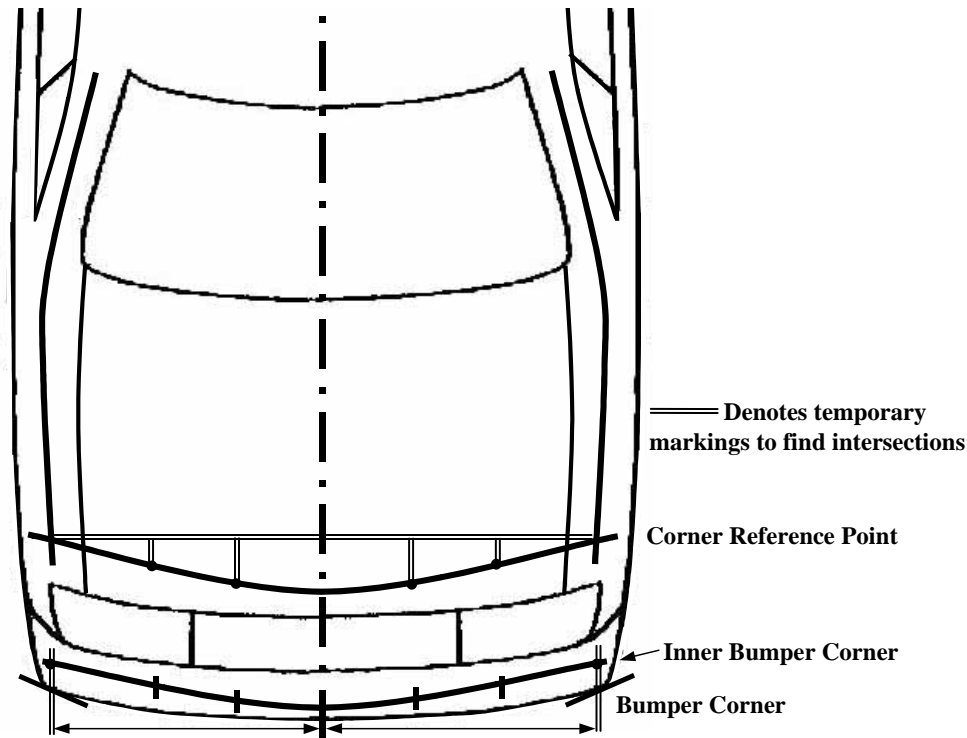

Figure 2.11

Division of the Bonnet Leading Edge and Upper Bumper Reference Lines

2.12 Bumper Lead

This is defined as the horizontal distance between the Bonnet Leading Edge Reference Line and the Upper Bumper Reference Line. The bumper lead may vary across the front of the car; therefore, the bumper lead must be measured separately at all selected bonnet leading edge impact points.

2.12.1 The bumper lead will be used in Section 8.

2.12.2 Position a vertical straight edge in contact with the Upper Bumper Reference Line positioned longitudinally to align with the Bonnet Leading Edge impact point chosen later in Section 3.

2.12.3 Measure the horizontal longitudinal distance from the Bonnet Leading Edge Reference Line to the vertical straight edge. This is the bumper lead at that point. Alternatively a 3D measuring arm can be used to establish this distance. Record the Bumper Lead for each impact point.

2.13 Bonnet Leading Edge Height

This is defined simply as the vertical height above the ground of the Bonnet Leading Edge Reference Line. This line follows the contours of the bonnet and its height may vary across the front of the car, therefore, the bonnet leading edge height must be measured separately at all

selected Bonnet Leading Edge impact points, which will be chosen in Section 3.

2.13.1 The bonnet leading edge height will be used in Section 8.

2.13.2 Position a horizontal straight edge with one end in contact with the impact point on the Bonnet Leading Edge Reference Line and measure the vertical distance to the ground. Alternatively use a 3D measuring arm to measure and record the Bonnet Leading Edge height for each impact point.

2.14 Labelling the Bonnet Leading Edge and Bumper Test Zones

2.14.1 Beginning with the Bonnet Leading Edge Reference Line, move from the right hand side of the vehicle to the left hand side of the vehicle the first third (two sixths) is labeled U1. The remaining thirds are then labeled U2 and U3.

2.14.2 Each third has been divided into two, beginning with the first sixth within U1, label from the right hand side of the vehicle to the left hand side of the vehicle alphabetically i.e. A and B. Repeat this for the remaining two thirds.

2.14.3 Repeat steps 2.14.1 and 2.14.2, for the Bumper Reference Lines, replacing U with L. See Figure 2.12.

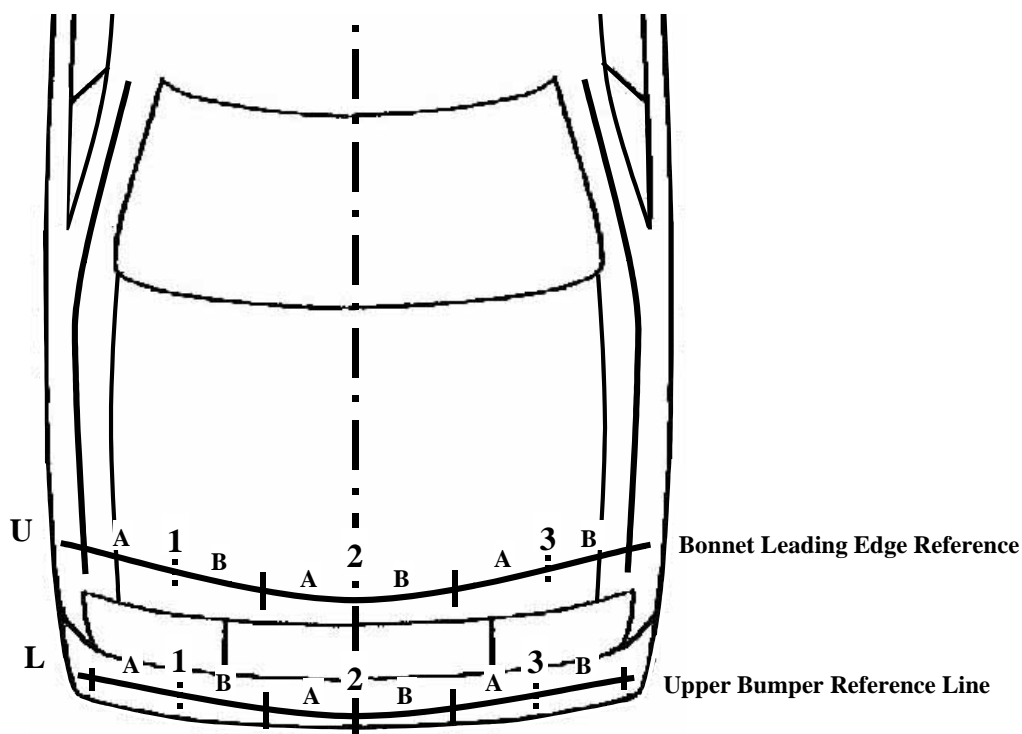

Figure 2.12
Labelling the Bonnet Leading Edge and Bumper Test Zones

3 DETERMINATION OF IMPACT POINTS

3.1 Legform to Bumper Test

3.1.1 The legform to bumper tests will only be conducted if the lower bumper reference line at the impact point is less than 500mm above the ground when the test vehicle is at its Normal Ride Attitude. However, for vehicles where part or all of the Lower Bumper Reference Line is above 500mm, select the Bumper impact points as in 3.1.1.1 to 3.1.1.4. For those impact points where the Lower Bumper Reference Line is above 500mm refer to Section 3.2.

The impact points shall be chosen in accordance with the following:

3.1.1.1 There shall be three EuroNCAP chosen impact points on the bumper.

3.1.1.2 The impact points shall be a minimum of 66mm inside the Bumper Corners. Where there are structures outboard of the corner reference points, which are deemed to be injurious, Euro NCAP reserve the right to perform a test to those structures.

3.1.1.3 No impact point may be closer than 132mm to any other bumper impact point.

3.1.1.4 The three EuroNCAP impact points should be chosen for areas which are judged to be the most likely cause of injury.

Where a manufacturer considers that the single EuroNCAP impact point, in a particular third, would not adequately reflect the performance of that area, the vehicle manufacturer may fund and nominate an additional test in the adjacent half next to the EuroNCAP impact point. The manufacturer must choose their nominated test zones (for all impactors) before any testing begins, once the manufacturer has nominated the desired test zones, EuroNCAP will then choose the impact point which is judged to be the most likely cause of injury within each of the nominated test zones. One EuroNCAP legform test is performed in either of the first two sixths, one in either of the middle two sixths and one in either of the final two sixths. The manufacturer nominated test zones (up to a maximum of three) can be in one or more of the remaining sixths. Where any of the impact points are centred on an internal border of a third, the manufacturer can choose which of the adjacent test zones it is deemed to be in. The test in the other zone would then have to comply with the spacing requirements between impact points.

3.1.1.5 If symmetrically identical impact points are present, both points may be chosen. However, the score for the second point may be taken to be the same as that of the first, without being tested, unless the car manufacturer provides evidence to suggest that the rating would be different or, for the manufacturer's nominated test zones, EuroNCAP expect different results. Agreement between the test house and manufacturer on all symmetrical impact points should be reached before testing begins, disputes will be referred to the EuroNCAP secretariat.

3.1.2 Often the most injurious locations will be at similar points on all cars and some suggestions are made below. However, the following should be used as a *guide only*. EuroNCAP may decide to test other areas, if they appear particularly aggressive. The following examples are given for illustrative purposes only and need not be chosen for testing:

- i) Towing eye. This is normally mounted on the right or left front lower rails. If the eye is removable, carry out the test without it, and fit the applicable cover over the hole.
- ii) Centre of the licence plate mount. This will normally be equidistant from the

right and left bumper mounts.

iii) Any localised crumple-can, these are often located in front of the lower rails.

3.1.3 Place a mark on the bumper to represent the point of impact of the centre of the legform.

3.1.4 The test point is labelled using the name of the zone in which it falls. See Figure 3.0.

3.1.5 If the manufacturer wishes to nominate additional tests the point will be labelled in the same way as 3.1.4, but it will contain an additional label, in lower case characters, to signify the zone which was nominated. See Figure 3.1.

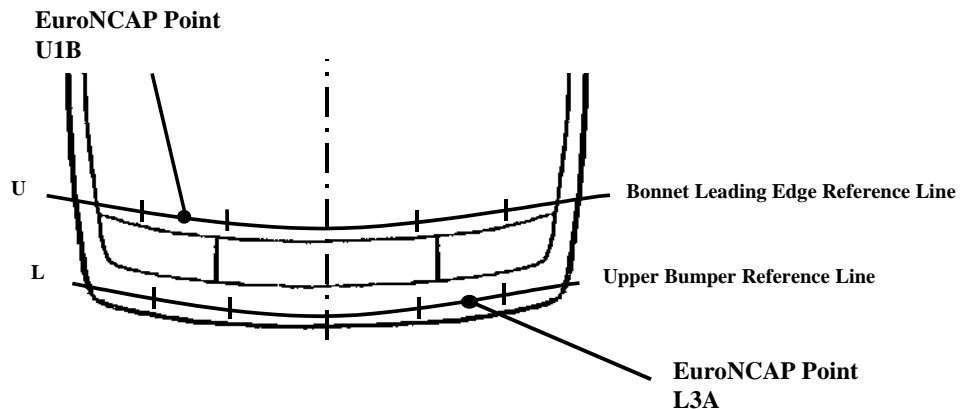

Figure 3.0

Impact point labelling in the Bonnet Leading Edge and Bumper Reference Line test zones

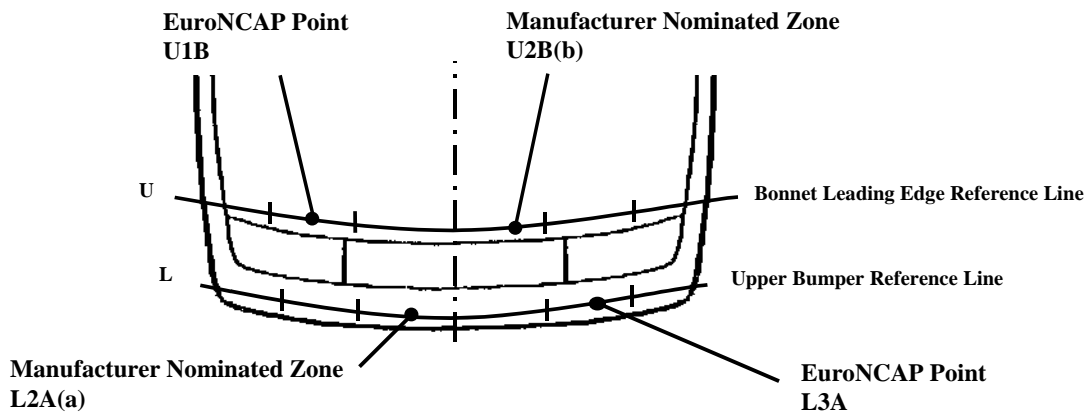

Figure 3.1

Additional impact point labelling in the Bonnet Leading Edge and Bumper test zones

3.2 Upper Legform to Bumper Test

3.2.1 These tests are conducted, instead of the legform to bumper tests, if the Lower Bumper Reference Line at the position(s) defined in Section 3.1.1.4, is greater than 500mm vertically above the ground at the vehicle's normal ride attitude.

3.2.1.1 The upper legform to bumper tests must be carried out at the same lateral position as the

points selected in Paragraph 3.1.1.4, with the intersection of the longitudinal and lateral planes, at the centre of the impactor, aimed mid way between the Upper Bumper Reference Line and the Lower Bumper Reference Line.

3.3 Upper Legform to Bonnet Leading Edge

3.3.1 A test is not required if the calculated impact energy would be 200J or less. The impact locations shall be chosen using a method similar to Section 3.1 but with the following changes:

3.3.1.1 The impact points shall be marked on the Bonnet Leading Edge Reference Line.

3.3.1.2 The selected impact points must be at least 75mm from the Corner Reference Points and at least 150mm apart.

Where a manufacturer considers that the single EuroNCAP impact point, in particular third, would not adequately reflect the performance of that area, the vehicle manufacturer may fund and nominate an additional test in the adjacent half next to the EuroNCAP impact point. The manufacturer must choose their nominated test zones (for all impactors) before any testing begins, once the manufacturer has nominated the desired test zones, EuroNCAP will then choose the impact point which is judged to be the most likely cause of injury within each of the nominated test zones. One EuroNCAP upper legform test is performed in either of the first two sixths, one in either of the middle two sixths and one in either of the final two sixths. The manufacturer nominated test zones (up to a maximum of three) can be in one or more of the remaining sixths. Where any of the impact points are centred on an internal border of a third, the manufacturer can choose which of the adjacent test zones it is deemed to be in. The test in the other zone would then have to comply with the spacing requirements between impact points.

3.3.1.3 If symmetrically identical impact points are present, both points may be chosen. However, the score for the second point may be taken to be the same as that of the first, without being tested, unless the car manufacturer provides evidence to suggest that the rating would be different or, for the manufacturer's nominated zone(s), EuroNCAP expect different results. Agreement between the test house and manufacturer on all symmetrical impact points should be reached before testing begins, disputes will be referred to the EuroNCAP secretariat.

3.3.2 Test three points at those locations which are considered to be the most injurious within a test zone. Often, the most injurious locations will be at similar points on all cars and some suggestions are made below. However, the following should be used as a *guide only*, other locations should be chosen if they appear more aggressive:

- i) Over the centre of the headlight
- ii) Over the bonnet catch

3.3.3 After the impact points have been marked, additional marks shall be made on the Upper Bumper Reference Line which are in the same vertical longitudinal plane as the marks on the Bonnet Leading Edge Reference Line. The marks made on the bumper will be used (Section 8.3.1) to determine the Bonnet Leading Edge Height and the Bumper Lead at the impact points.

3.3.4 The impact point is labelled using the name of the test zone in which it falls, see Figure 3.0.

3.3.5 If the manufacturer wishes to nominate additional tests the impact point will be labelled in the same way as 3.1.5. See Figure 3.1.

3.4 Adult and Child Headforms - Structures to be tested

- 3.4.1 To reduce the test programme size there will be a maximum of 12 EuroNCAP chosen impact points to the vehicle.
- 3.4.2 Raise the bonnet and conduct a visual survey of the engine bay and the inner and outer wings to decide which locations are liable to cause injury. Only structures and objects which are relatively close to the bonnet, when it is shut, are likely to cause injury. Attention should also be paid to the bonnet itself to determine whether the stiffening in the bonnet could cause injury.
- 3.4.3 The structures to be tested shall be in accordance with the following:
- 3.4.3.1 The projected points (see Section 3.5) for the child headform shall be in the child headform zone (see Figure 2.9, zone C) of the bonnet top which lies between the 1000mm and 1500mm wrap around lines.
- 3.4.3.2 The projected points for the adult headform shall be in the zone between 1500mm and 2100mm wrap around lines, see Figure 2.9, zone A.
- 3.4.3.3 The projected points for the child headform shall be a minimum of 65mm inside the Bonnet Side Reference Lines and a minimum of 130mm apart i.e. no two points (as represented in the child headform zone) either within any sixth or in adjacent sixths should be less than 130mm apart. Where testing on an A-Pillar is involved the minimum distance inside the side reference line for the impact point does not apply. The impact point in this case may be on the side reference line.
- 3.4.3.4 The projected points for the adult headform shall be a minimum of 82.5mm inside the Bonnet Side Reference Lines and a minimum of 165mm apart i.e. no two points (as represented on the bonnet surface) either within any sixth or in adjacent sixth should be less than 165mm apart. Where testing on an A-Pillar is involved the minimum distance inside the side reference line for the impact point does not apply. The impact point in this case may be on the side reference line.
- 3.4.3.5 The spacing requirements (Sections 3.4.3.3, 3.4.3.4) are only applicable to impact points using the same impactor, i.e. adult and child impact points can be coincidental.
- 3.4.3.6 Test at one location within each sixth which is considered to be the most potentially injurious structure within that sixth. Often, such locations will be at similar points on all cars and some suggestions are made below. However, the following should be used as a *guide only*, other locations should be chosen if they appear more aggressive:
- i) Top of suspension strut
 - ii) Bonnet hinge
 - iii) Top of rocker cover
 - iv) Battery terminal
 - v) Windscreen wiper spindle
 - vi) Brake master cylinder
 - vii) Heavy under-bonnet reinforcement
 - viii) Elevated firewall
 - ix) Bonnet and wing edges
 - x) A-pillars
 - xi) Windscreen base
 - xii) Roof line (if applicable)

NOTES:

Where locations are translated from beneath the bonnet to the bonnet surface (projected points, see Section 3.5) the in which the projected point falls determines whether the projected point is in the adult or child headform zone.

Where a manufacturer considers that the single EuroNCAP impact point, in a particular sixth, does not adequately reflect the performance of that area, the vehicle manufacturer may fund one additional test in the remaining test zones. This process can be repeated in any or all of the other sixths, which does not contain a EuroNCAP impact point. The manufacturer must choose their nominated test zones (for all impactors) before any testing begins, once the manufacturer has nominated the desired test zones, EuroNCAP will then choose the impact point which is judged to be the most likely cause of injury within each of the nominated test zones. The EuroNCAP impact point will reside in one of the quarters. The manufacturer may then nominate that any one, two or three of the remaining quarters be assessed by the additional test. Where any of the projected points are centred on an internal border of a sixth, the manufacturer can choose which of the adjacent test zones it was deemed to be in. A test in the other zones would then have to comply with the spacing requirements between projected points.

For the headform area, impact points chosen on the glass, with no structure within range behind the glass, shall default to "green" (2 Points) and impact points chosen on the A-Pillar default to "red" (0 points) without testing. If the manufacturer provides data which shows otherwise a test shall be performed. Any other parts of the car, within the periphery of a cylinder of diameter equal to that of the headform and having the same axis at the impact point, which may influence the protection of an impacting head, would also justify a test. See Figure 3.2, note the effect of gravity on the impactor has been ignored for the diagram, this should be considered in practice.

Tests on the windscreen or which might damage the windscreen surround should be conducted after the car side impact test has been carried out.

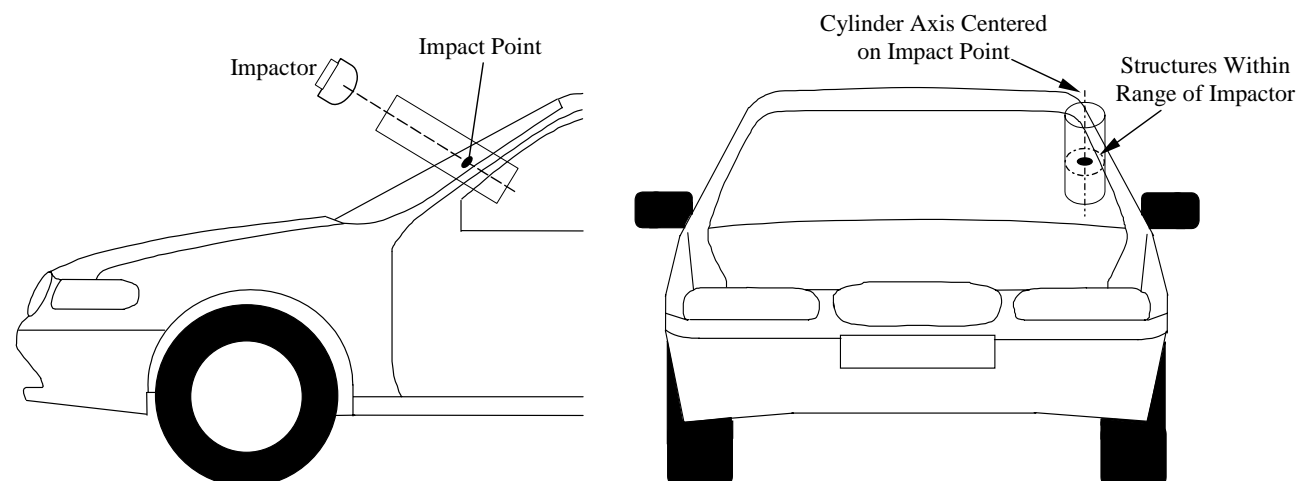

Figure 3.2
Structures within range of the impactor

3.4.3.7 If symmetrically identical impact points are present, both points may be chosen. However, the score for the second point may be taken to be the same as that of the first, without being tested, unless the car manufacturer provides evidence to suggest that the rating would be different or, for the manufacturer's nominated test zone(s), EuroNCAP expect different results. Agreement between the test house and manufacturer on all symmetrical impact points should be reached before testing begins, disputes will be referred to the EuroNCAP secretariat.

3.4.3.8 The impact point is labelled using the name of the test zone in which it falls. See Figure 3.3.

3.4.3.9 If the manufacturer wishes to nominate additional tests the impact point will be labelled in the same way as 3.1.5. See Figure 3.3.

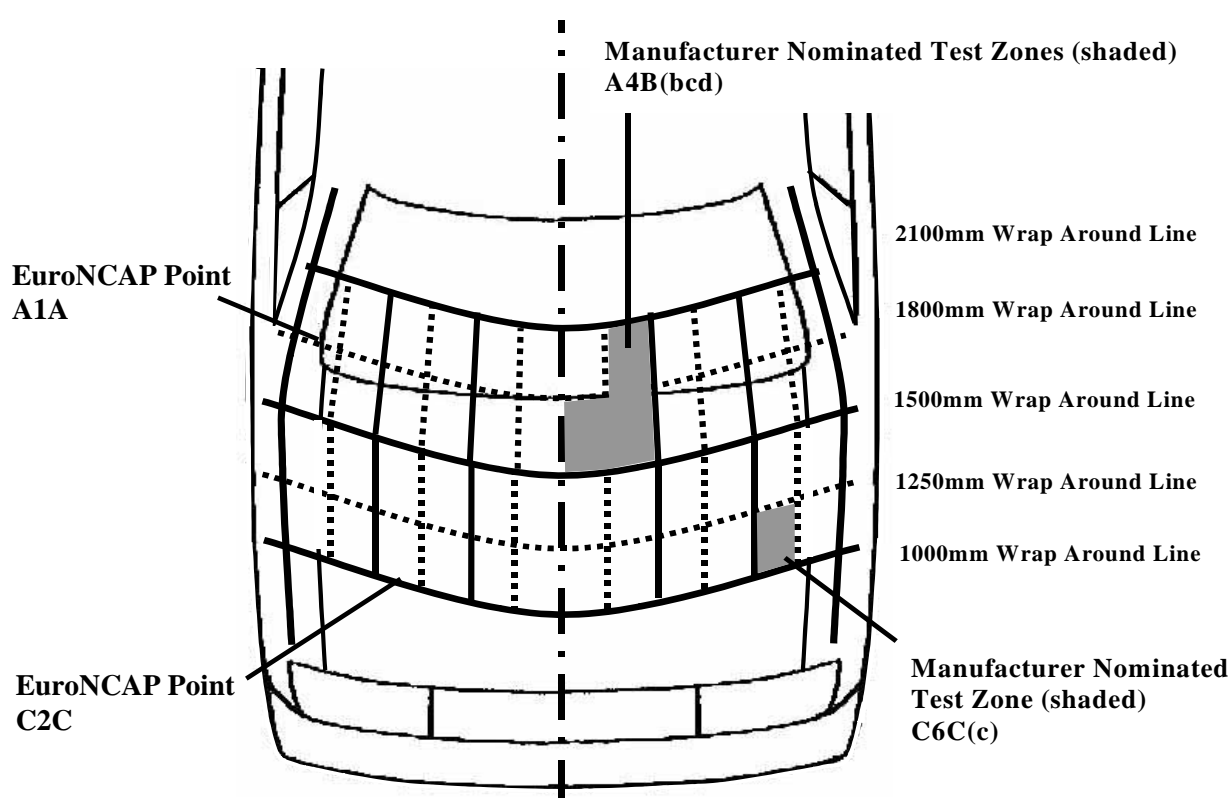

Figure 3.3
Impact point labelling in the headform zones

Figure 3.3 shows some examples of how impact points should be labeled. EuroNCAP has chosen the impact point A1A; the first letter A signifies the adult headform zone; number 1 is the first sixth within the adult headform zone; and the last letter, 'A' is for test zone A in the first sixth of the adult headform zone. All points that are chosen by EuroNCAP will be labeled in the same way, e.g. point C2D in Figure 3.3.

Point A4B(bcd) is an example of an additional impact point that has been chosen by EuroNCAP in test zone(s) nominated by the manufacturer. The first three characters are labeled in the same way as mentioned above. Any test number that contains lower case characters within brackets

signifies that the test is additional; and that the test zone(s) nominated by the manufacturer are (bcd). Further additional tests will be labeled in the same way. If the manufacturer nominates one test zone only e.g. (c), then this will be at the end of the impact point label, as is the case for impact point C6C(c) in Figure 3.3.

3.5 Headform to Bonnet top – Selecting the first point of contact on the vehicle to account for underlying structures.

3.5.1 Using the 3D Measurement Arm, or a device with similar accuracy and reliability, if the most injurious structures are beneath the bonnet surface they will be transferred and recorded to the bonnet surface (projected points). Close the bonnet and use the measuring arm to locate and mark those points on the bonnet top, that are forward and parallel to the centreline of the vehicle, at a 50 degree angle for the child headform tests and a 65 degree angle for the adult headform tests, from the structure chosen beneath the bonnet. The Y (lateral) co-ordinates should remain the same on the bonnet surface as the structure chosen beneath the bonnet. Alternatively the transfer of projected points from beneath the bonnet to the bonnet surface can be done with the use of a laser. It is necessary for the laser to be set in the fore/aft direction of the vehicle and angled at 50 degree for the transference of child headform impact points and 65 degree for the adult. The transference of these points to the bonnet top does not necessarily coincide with the headform's point of first contact, impact point.

3.5.2 There are two effects which would determine where the impact point (point of first contact) on the bonnet top is in relation to the point where the centre line of the propulsion system intersects with the car bonnet. These effects are:

3.5.2.1 Gravity

Under the influence of gravity the headform will deviate from the trajectory it has initially when leaving the propulsion system.

3.5.2.2 Point of contact not at centre line of headform

As the headform does not necessarily impact normal to the bonnet top, the point of first contact on the headform will not be the centre point of the headform in the direction of travel. See Figure 3.4a.

3.5.2 Where an injurious point is located on the bonnet surface, e.g. the wing edge, then the headform should be aimed so that the headform's point of first contact is with the injurious point, see Figure 3.4a.

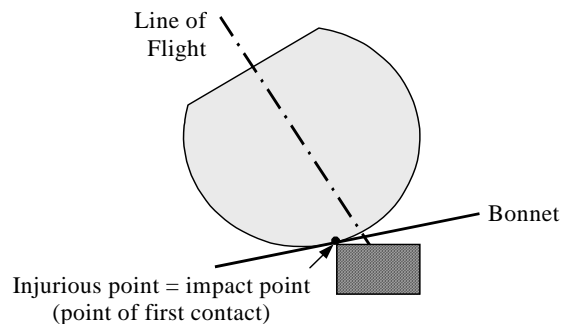

Figure 3.4a
Determination of impact point on the bonnet surface

Where an injurious point is located deep beneath the bonnet surface but still liable to cause injury, e.g. the battery terminal, then the headform should be aimed so that the headform's centre line is set to align with the injurious point, see Figure 3.4b.

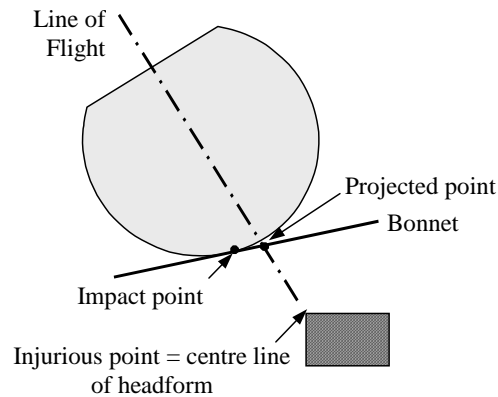

Figure 3.4b

Determination of impact point for a structure deep beneath the bonnet surface

For structures that are in positions between the two extremes, the headform should be aimed with the centre line and point of first contact at specific distances (dependent upon depth and firing angle) either side of the injurious point in order to ensure the underlying structure is fully contacted, see Figure 3.4c.

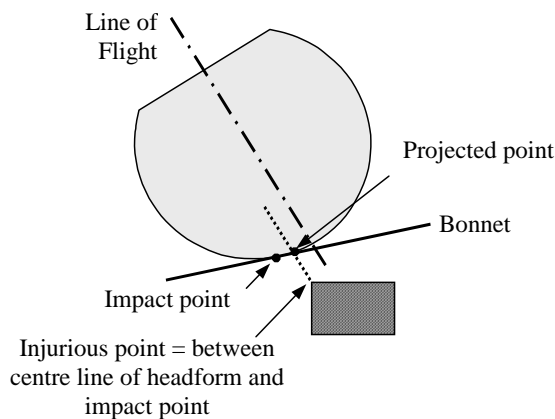

Figure 3.4c

Determination of impact point for a structure just beneath bonnet surface

The exact impact point for the three examples is at the judgement of EuroNCAP and should be made so that the most injurious results are recorded. The effect of any small variation in the impact point is also likely to be small. The point of first contact on the bonnet surface should always be marked on the bonnet as this is required to determine the accuracy of the impact, and to ensure a consistent marking scheme is used.

The above method also applies when there is an injurious structure behind the windscreen, e.g. instrument panel, windscreen glass mounting. In such a case the impact point will be higher up the windscreen the deeper the structure is beneath the windscreen surface.

3.5.4 Effects described in section 3.5.2 must be taken into account in determining the Aiming Point for the impact test gun.

3.5.4.1 The determination of where to aim the firing mechanism will require the following information:

- Headform Diameter
- Distance that the headform must travel after leaving the propulsion system
- Required angle of impact to horizontal
- Angle of the bonnet top at the point of impact
- Required impact velocity
- Location of the chosen injurious point

3.5.4.2 Using the above information calculate the distance from the impact point (point of first contact) that the propulsion system should be aimed (aiming point) to ensure that the required point of first contact is hit. The angle to which the propulsion system should be set and the velocity that the propulsion system must give to achieve the required velocity at impact and the required angle of incidence at impact must also be calculated.

3.5.4.3 Measure up the bonnet from the distance calculated in 3.5.4.2 and mark a point. This should be marked as the aiming point as found in 3.5.4.1.

3.5.5 This procedure should be used to mark up all of the structures to be tested at the bonnet.

3.6 For headform tests to the windscreen base, A-pillars and/or roof line, then the impact points will be selected in a similar manner to that described in Section 3.5. Corrections for gravity and the desired point of contact not along the centre line of the headform (to consider injurious underlying structures) will also follow the methods specified in Section 3.5.

4 RECORDING THE IMPACT POINT LOCATIONS

4.1 General

- 4.1.1 A three dimensional measuring arm shall be used to record the projected points and impact points in three dimensional space. For the Bumper and Bonnet Leading Edge record the position of the impact point placed on the Upper Bumper Reference Line and the Bonnet Leading Edge Reference Line respectively, at the chosen lateral test positions. For the bonnet top, A-pillar, windscreen and roof record the position of markers placed on the selected impact points. The following is only an example of the EuroNCAP procedure and as such a device of similar accuracy and reliability may be used in place of the 3D arm (tolerance of $\pm 0.5\text{mm}$).
- 4.1.2 Care should be taken at all times not to move the vehicle while the impact points are being recorded or transferred.

4.2 Brief Description of the 3D Measuring Arm

- 4.2.1 For vehicle deformation and intrusion measurements and for marking vehicles, a FARO 3D measuring arm, consisting of a series of accurate rotational transducers which can calculate the position of a pointer at its end at any time, will be used. This information is fed in to a computer and can be stored as a series of 3 dimensional co-ordinates. The arm requires an axis system to be set up relative to the object to be measured, typically the transverse, longitudinal and vertical directions of a vehicle. An origin is first needed followed by a point on the positive x axis and then a point in the positive x-y plane.

4.3 Setting Up 3D Measuring Arm Axes

Section 4.3 is an example method for setting up the 3D measuring arm axis, alternative methods that record and use a different datum can be used.

- 4.3.1 Place the test vehicle on an area of flat level floor.
- 4.3.2 Ensure that the steering wheel is in the 'neutral' position with the wheels pointing directly forward.
- 4.3.3 Mark a point on the floor which is 200mm lateral to the centre of one of the front wheels.
- 4.3.4 From this mark, draw a straight line 1500mm forward and parallel to the centre line of the vehicle.
- 4.3.5 Repeat steps 4.3.3 and 4.3.4 for the other front wheel.
- 4.3.6 Measure the distance between the two lines.
- 4.3.7 Join the two lines with a perpendicular line. This line should be perpendicular to the centre line of the car and will be used as the datum for measurements. See Figure 4.1

Datum line

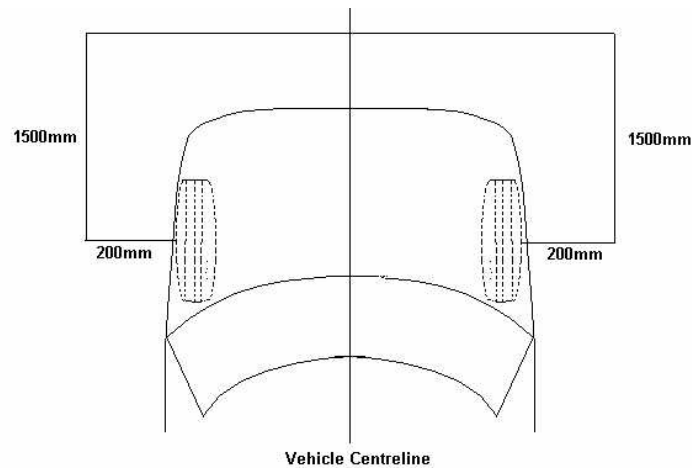

Figure 4.1
3D Arm axis set-up

- 4.3.8 Mark on the datum line the intersection with the vehicle centre line. Digitise this point with the 3D arm as the axis origin.
- 4.3.9 From the origin, extend a line that is perpendicular to the datum further out in front of the vehicle, see Figure 4.1. The line should extend at least 500mm. Digitise a point on this line. This defines the positive x-axis of the vehicle.
- 4.3.10 Digitise a point in the horizontal plane in front of the datum line and to the *right* of the centre line of the vehicle. This defines the positive x-y plane.
- 4.3.11 The arm will now be set up with positive x forwards, positive y right and positive z down, in accordance with SAE J211 practices.

4.4 Digitising Impact Points

- 4.4.1 Ensure that the vehicle is at its test weight and fully test prepared as defined in Section 1.
- 4.4.2 Measure the ride heights at all four wheels using the marks defined in Section 1.3.4. Record the ride heights in the test details.
- 4.4.3 During digitising, care should be taken not to move the vehicle by, for example, leaning on it.
- 4.4.4 The co-ordinates of all impact locations defined in Section 3 should be digitised with the 3D arm. For each of the bonnet leading edge locations, record both the co-ordinates of the location and that point on the Upper Bumper Reference Line in the same longitudinal vertical plane as it.
- 4.4.5 With the bonnet open, use the arm to determine the 3 dimensional co-ordinates of the selected injurious points beneath the bonnet surface, see Section 3.
- 4.4.6 Close the bonnet and use the measuring arm to locate and mark the impact points on the bonnet top, as calculated in Section 3.5. The Y (lateral) co-ordinates should remain the same on the bonnet top as the structure chosen beneath the bonnet.
- 4.4.7 A hard copy of the impact points' co-ordinates should be obtained for reference.
- 4.4.8 After digitisation, the bonnet top featuring all the impact points shall be removed and a replacement bonnet fitted (see Section 5.3 for fitting procedures).
- 4.4.9 The original bonnet shall be kept for reference.

4.5 Transferring Impact Points to Replacement Vehicle Parts

Many replacement parts will need to be fitted to the vehicle for this series of tests. It is not practical to have to mark out each of the parts completely for a single test. Therefore, the original marked-out bonnet will be retained as a reference and individual impact locations transferred to replacement components.

- 4.5.1 With the new component fitted, measure the ride heights at all four wheels.
- 4.5.2 These ride heights must be altered until they match the original recorded ride heights (Section 1.3). If the ride heights are too high then they can be reduced by adding weights. If the ride heights are too low then they can be increased by removing weight from the vehicle and/or inserting blocks under the body of the vehicle. The additional weights and/or blocks shall be removed before testing.
- 4.5.3 Set up the 3D measuring arm and its axes as described in Section 4.3.
- 4.5.4 Using the co-ordinates recorded in Section 4.4 for the original impact points, locate and mark the desired impact point on the new component.

5 PERFORMING OF PEDESTRIAN IMPACT TESTS

5.1 General

- 5.1.1 Safety to personnel shall be a priority at all times
- 5.1.2 Ensure that all equipment used is in full working order, has been checked for safety and is in calibration where appropriate

5.2 Propulsion System

- 5.2.1 An air, spring or hydraulic gun will be used to propel the various body form impactors.
- 5.2.2 For the legform and the headform tests the impactors are required to be in free flight at the time of impact.

5.3 Fitting Replacement Parts to Vehicles

- 5.3.1 Careful note shall be taken before any testing is performed as to how any parts liable to need replacement are fitted to the vehicle structure.
- 5.3.2 Fitting of parts shall not increase or decrease the strength of the structure of the vehicle.
- 5.3.3 If significant repair work is required, this will be done at a manufacturer-approved dealer.

5.4 Photographic Record

- 5.4.1 A photographic record shall be kept of each test.
- 5.4.2 Before any testing has been conducted but after the vehicle is fully test prepared including all markings, the vehicle shall be photographed according to the following schedule. Note that these shall be the only pre-test photographs taken.

5.4.3 List of still photographs

<u>Amount of vehicle visible</u>	<u>View Point</u>
Full vehicle	Left side
Full vehicle	Right side
Front third vehicle	Left side
Front third vehicle	Right side
Full vehicle	Front
Left half vehicle	Front
Right half vehicle	Front
Front third of vehicle	Top
Front third, right half of vehicle	Top
Front third, left half of vehicle	Top
Legform test points	Front
Upper legform test points	Front
Child headform test points	Top
Adult headform test points	Top

- 5.4.4 Post-test photographs are detailed for each test type in the individual test procedures.

6 LEGFORM TESTS

6.1 Description of Legform and its Instrumentation

6.1.1 The legform impactor used shall conform to that specified in EEVC WG17 Report, 'Improved Test Methods to Evaluate Pedestrian Protection Afforded by Passenger Cars', December 1998. This test shall be performed if the Lower Bumper Reference Line (see section 2.2.7) is less than 500mm above the ground at the impact point. All impact points shall be a minimum of 66mm inside the Bumper Corners (Section 2.3), and be a minimum of 132mm apart. These minimum distances are to be set with a flexible tape held tautly along the outer surface of the vehicle.

6.1.2 Instrumentation

Location	Measurement	CFC (Hz)	CAC	No of channels
Bottom of Femur	Angle (gives shear displacement)	180	*10mm/ 21.3°	1
Top of Tibia	Knee Bend Angle	180	50°	1
Tibia, non-impacted side	Acceleration	180	500g	1

**This does not require that the impactor itself be able to physically bend and shear to this angle.*

6.2 Certification

6.2.1 The certification procedures are detailed in EEVC Working Group 17 Report 'Improved Test Methods to Evaluate Pedestrian Protection Afforded by Passenger Cars' December 1998, Annex VII. [This document will follow subsequent changes to the certification procedure detailed above on any levels set provisionally. The Dynamic certification procedures are under review by WG17 at present. Until this review is complete the instructions of the impactor manufacturer should be followed.]

6.2.2 The legform shall be certified before the test programme.

6.2.3 The legform shall be re-certified after a maximum of 20 impacts and the foam replaced.

6.2.4 The legform shall be re-certified at least once every 12 months regardless of the number of impacts it has undergone.

6.2.5 If the legform exceeds any of its CACs then it shall be re-certified

6.3 Test Procedure - Pre Test

6.3.1 Ensure that the vehicle is fully test prepared as described in Section 1.

6.3.2 Ensure that the legform, the vehicle, the propulsion system and the data acquisition equipment has soaked in a temperature in the range of 16°C to 24°C for at least 2 hours prior to testing.

6.3.3 Fit a new piece of foam¹ to the legform and fit the neoprene skin over the foam.

6.3.4 Align the vehicle so that the propulsion system can aim at the impact position and the

¹ The foam shall be 25mm thick Confor™ foam type CF-45

propulsion system can fire the legform in a direction that is parallel to the vehicle centre line.

- 6.3.5 Roll the vehicle forwards to give the desired free flight distance.
- 6.3.6 At the time of first contact the bottom of the legform shall be at Ground Reference Level $\pm 10\text{mm}$. Insert blocks under the wheels of the vehicle such that vehicle height is raised as required by the gravity correction method used to ensure the above tolerance; and the tolerance for direction of impact specified in Section 6.3.20 are both satisfied. Alternatively, ensure that the vehicle is positioned above a trench in the floor. See Figure 6.1.

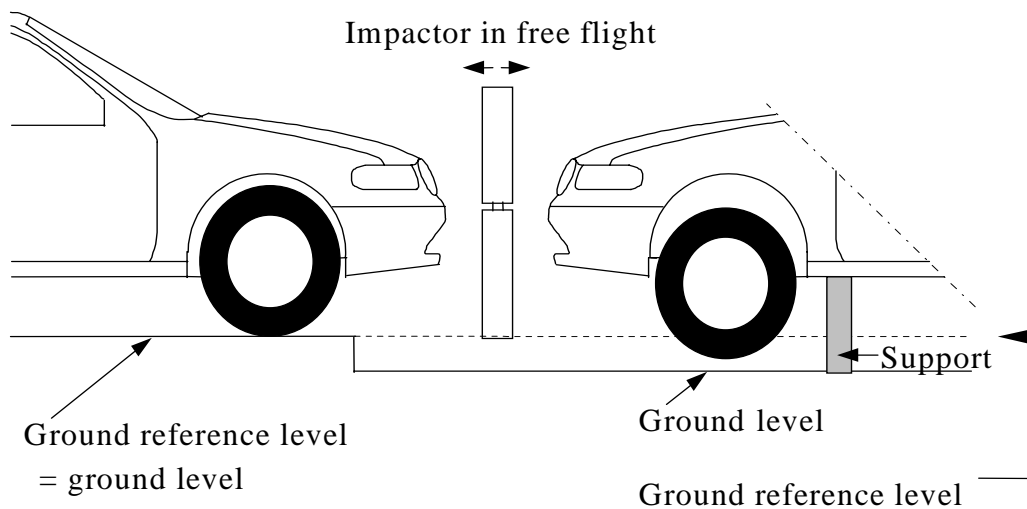

Figure 6.1
Legform to Bumper tests

- 6.3.7 If required, ensure the vehicle is at the same ride heights as those recorded during marking up of the vehicle, friction in the vehicle's suspension system may be a source of variance.
- 6.3.8 To ensure that the legform impacts with its bottom at the correct height above the ground a correction to take into account the action of gravity when the legform is in free flight is required. This can take the form of raising the legform a distance h , and firing it horizontally so that the action due to gravity results in the bottom of the impactor being at ground level at the point of first contact with the vehicle. This can be achieved using the method in Section 6.3.9 to 6.3.11. However, this method will only remain within the tolerance specified in 6.3.20 if its free flight distance is about 400mm or less. For test houses that use a free flight distance of more than 400mm then the legform shall be fired using a ballistic correction procedure as described in Section 6.3.13 to 6.3.18.

Compensation for Gravity (horizontal firing)

- 6.3.9 Measure the distance d (in metres) between the point of first contact and the point from where the legform will leave the propulsion system and begin free flight (release point).

$$\text{Fall due to Gravity } h = \frac{gd^2}{2v^2}$$

6.3.10 The distance that the legform will fall due to gravity can be calculated from the formula Assuming values for g , acceleration due to gravity = 9.81ms^{-2} and v , exit velocity of the legform from the propulsion system (at the release point) = 11.1ms^{-1} gives:

$$\text{Fall due to Gravity } h = 0.03981 d^2$$

6.3.11 Raise the propulsion system by this calculated amount, h . The angle θ must remain within the tolerance specified in Section 6.3.20. See Figure 6.2.

6.3.12 Proceed to Section 6.3.19.

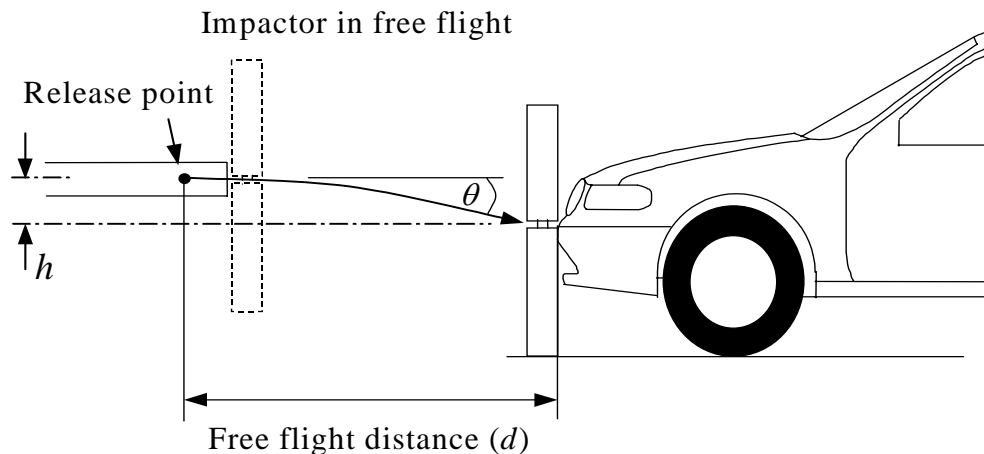

Figure 6.2
Droop Compensation

Ballistic Compensation

There are two procedures which can be used for ballistic compensation, it is at the discretion of the test house as to the most appropriate method, see Figure 6.3. The terms used for the calculations are:

At the release point:

u = initial velocity

ϕ = firing angle

At the point of first contact:

v = impactor velocity (11.1m/s)

θ = direction of impact (0°)

d = free flight distance

h = height increase

6.3.13 The first case is where ϕ is fixed, and $\theta = 0^\circ$, $v = 11.1\text{m/s}$. The vehicle must be positioned in relation to the fixed propulsion system, therefore u , d , and h are the subjects.

6.3.14 Using the following equations find u , d , and h :

$$u = \frac{v}{\cos(\phi)}$$

$$d = \frac{v^2}{g} \tan(\phi)$$

$$h = \frac{v^2}{2g} \tan^2(\phi)$$

6.3.15 Position the vehicle to be the correct distance away from, and height above the release point. Proceed to Section 6.3.19.

6.3.16 The second case is where d is fixed, and $\theta = 0^\circ$, $v = 11.1\text{m/s}$. The propulsion system is positioned and aimed in relation to the vehicle, therefore u , h and ϕ are the subjects.

6.3.17 Using the following equations find u , h and ϕ :

$$u = v \left(1 + \frac{g^2 d^2}{v^4} \right)^{\frac{1}{2}}$$

$$h = \frac{gd^2}{2v^2}$$

$$\phi = \tan^{-1} \left(\frac{gd}{v^2} \right)$$

6.3.18 Position the propulsion system to be the correct distance away from, height above and correctly aimed at the vehicle.

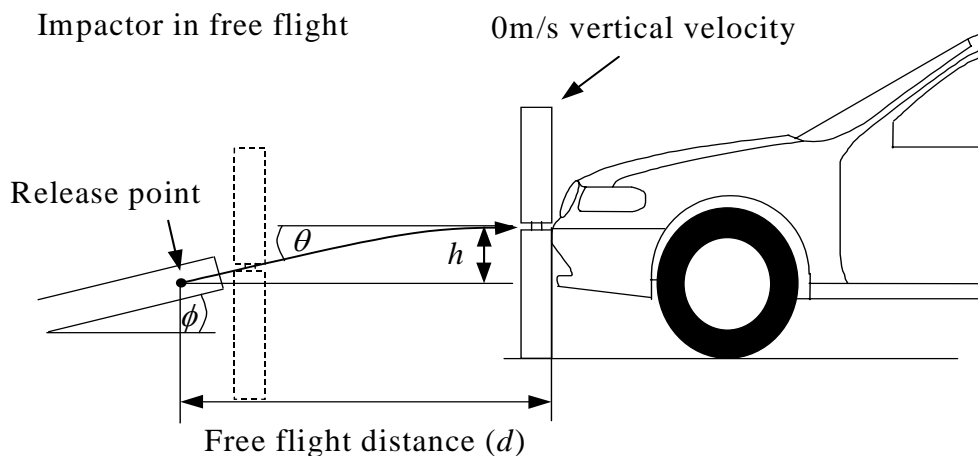

The angle ϕ shall be set so that the impactor is at the top of the ballistic at the point of first contact.

Figure 6.3
Ballistic Correction Procedure

- 6.3.19 Set the speed control on the propulsion system to give $11.1\text{m/s} \pm 0.2\text{m/s}$ at the point of first contact. The velocity measuring device should be able to measure to an accuracy of at least $\pm 0.02\text{ m/s}$. The effect of gravity shall be taken into account when the impact velocity is obtained from measurements taken before the point of first contact.
- 6.3.20 The direction of impact at the point of first contact shall be in the horizontal plane and parallel to the longitudinal vertical plane of the vehicle. The axis of the legform shall be vertical at the time of first contact. The tolerance to these directions is $\pm 2^\circ$.
- 6.3.21 At the time of first contact the impactor shall have the intended orientation about its vertical axis, for correct operation of the knee joint, with a tolerance of $\pm 5^\circ$.
- 6.3.22 At the time of first contact the centre line of the legform impactor shall be within $\pm 10\text{mm}$ of the selected impact point.
- 6.3.23 During contact between the legform impactor and the vehicle, the impactor shall not contact the ground or any object not part of the vehicle.
- 6.3.24 Fire the propulsion system.

6.4 Test Procedure - Post Test

- 6.4.1 Take at least two still photographs of the resultant dent, one from the side and one from the front. Each photograph shall have some means of identifying the vehicle and test location. The preferred method shall be to use unique run numbers for each test.
- 6.4.2 Additional photographs may be required for an individual test at the Project Managers discretion.
- 6.4.3 Check that no CAC has been exceeded before conducting the next test, if this has occurred then the impactor must be re-certified before the next test.
- 6.4.4 Replace any damaged part of the vehicle that will affect the results of the next test with new parts according to Section 5.3.
- 6.4.5 Repeat procedure for the next impact location.

7 UPPER LEGFORM TO BUMPER TESTS

7.1 Description of Upper Legform and its Instrumentation

7.1.1 The upper legform impactor used shall conform to that specified in EEVC WG17 Report, 'Improved test methods to evaluate pedestrian protection afforded by passenger cars', December 1998. This test shall be performed if the Lower Bumper Reference Line (see section 2.2.7) at the impact point is more than 500mm above the ground. All tests will be performed at the impact points determined in Section 3.1. The minimum distances to be used for this impactor are specified in 6.1.1, they shall be set with a flexible tape held tautly along the outer surface of the vehicle.

7.1.2 Instrumentation

Location	Measurement	CFC (Hz)	CAC	No of channels
Upper femur	Force	180	10kN	1
Lower femur	Force	180	10kN	1
Centre of femur	Bending moment	180	1000Nm	1
50mm above centre of femur	Bending moment	180	1000Nm	1
50mm below centre of femur	Bending moment	180	1000Nm	1

7.2 Certification

7.2.1 The certification procedures are detailed in EEVC Working Group 17, 'Improved test methods to evaluate pedestrian protection afforded by passenger cars', December 1998, Annex VII.

7.2.2 The upper legform shall be certified before the test programme.

7.2.3 The foam sheet² from which the pieces of foam shall be taken shall be certified before the test programme.

7.2.4 The upper legform shall be re-certified after a maximum of 20 impacts.

7.2.5 The upper legform shall be re-certified at least once every 12 months regardless of the number of impacts it has undergone.

7.2.6 If the upper legform exceeds any of its CACs then it shall be re-certified.

7.3 Test procedure - Pre-test

7.3.1 Ensure that the vehicle is fully test prepared as described in Section 1.

7.3.2 Ensure the vehicle is at the normal ride attitude as recorded during marking up of the vehicle.

7.3.3 Ensure that the upper legform, the vehicle, the propulsion system and the data acquisition equipment has soaked in a temperature in the range of 16°C to 24°C for at least 2 hours prior to testing.

² The foam shall be 25mm thick ConforTM foam type CF-45

- 7.3.4 The total mass of the upper legform impactor including those propulsion and guidance components which are effectively part of the impactor during the impact shall be 9.5kg \pm 0.1kg. The upper legform impactor mass may be adjusted from this value by up to \pm 1kg, provided the required impact velocity is also changed using the formula:

$$V = \sqrt{\frac{1170}{M}}$$

Where: V = impact velocity (m/s)
 M = mass (kg), measured to an accuracy of better than \pm 1%

- 7.3.5 The total mass of the front member and other components in front of the load transducer assemblies, together with those parts of the load transducer assemblies in front of the active elements, but excluding the foam and skin, shall be 1.95 \pm 0.05 kg.
- 7.3.6 Fit new pieces of foam, from the certified sheet of foam, to the upper legform.
- 7.3.7 Align the vehicle so that the propulsion system can aim at the impact position as defined in Section 3.2.1.1 and the propulsion system can propel and guide the upper legform in a direction that is parallel to the vehicle centre line \pm 2°. At the time of first contact the impactor centre line shall be midway between the Upper Bumper Reference Line and the Lower Bumper Reference Line with \pm 10 mm tolerance and laterally with the selected impact location with a tolerance of \pm 10 mm.
- 7.3.8 The impact velocity of the upper legform impactor when striking the bumper shall be 11.1m/s \pm 0.2m/s. The velocity measuring device should be able to measure to an accuracy of at least \pm 0.02 m/s. The effect of gravity shall be taken into account when the impact velocity is obtained from measurements taken before the point of first contact.
- 7.3.9 Roll the vehicle forwards to give the desired distance, so that the impactor strikes the vehicle after it has been accelerated to the test speed and so that any end stops on the guidance system do not interfere with its interaction with the vehicle.
- 7.3.10 The direction of impact shall be in the horizontal plane and parallel to the longitudinal vertical plane of the vehicle. The axis of the upper legform shall be vertical at the time of first contact. The tolerance to these directions is \pm 2°.
- 7.3.11 Fire the propulsion system.

7.4 Test Procedure - Post Test

- 7.4.1 Take at least two still photographs of the resultant dent, one from the side and one from the front. Each photograph shall have some means of identifying the vehicle and test location. The preferred method shall be to use unique run numbers for each test.
- 7.4.2 Additional photographs may be required for an individual test at the Project Managers discretion.
- 7.4.3 Check that no CAC has been exceeded before conducting the next test, if this has occurred then the impactor must be re-certified before the next test.
- 7.4.4 Replace any damaged part of the vehicle which would affect the results of the next test with new parts according to Section 5.3.
- 7.4.5 Repeat procedure for the next impact location.

8 UPPER LEGFORM TO BONNET LEADING EDGE TESTS

8.1 Description of Upper Legform and its Instrumentation

8.1.1 The upper legform used shall conform to that specified in EEVC WG17 Report, 'Improved Test Methods to Evaluate Pedestrian Protection Afforded by Passenger Cars', December 1998. All impact points shall be a minimum of 75mm inside the Corner Reference Points (Section 2.6), and be a minimum of 150mm apart. These minimum distances are to be set with a flexible tape held tautly along the outer surface of the vehicle.

8.1.2 Instrumentation

Location	Measurement	CFC (Hz)	CAC	No of channels
Upper femur	Force	180	10kN	1
Lower femur	Force	180	10kN	1
Centre of femur	Bending moment	180	1000Nm	1
50mm above centre of femur	Bending moment	180	1000Nm	1
50mm below centre of femur	Bending moment	180	1000Nm	1

8.2 Certification

8.2.1 The certification procedures are detailed in EEVC WG17 Report, 'Improved Test Methods to Evaluate Pedestrian Protection Afforded by Passenger Cars', December 1998, Annex VII.

8.2.2 The upper legform shall be certified before the test programme.

8.2.3 The foam sheet³ from which the pieces of foam shall be taken shall be certified before the test programme.

8.2.4 The upper legform shall be re-certified after a maximum of 20 impacts.

8.2.5 The upper legform shall be re-certified at least once every 12 months regardless of the number of impacts it has undergone.

8.2.6 If the upper legform exceeds any of its CACs then it shall be re-certified

8.3 Determination of Impact Velocity, Impact Angle and Impact Energy

The shape of the front of the car determines the velocity, angle of incidence and kinetic energy of the impactor. Full details are given in EEVC WG17 Report, 'Improved Test Methods to Evaluate Pedestrian Protection Afforded by Passenger Cars', December 1998. The velocity, angle of impact and total kinetic energy of the impactor will be calculated from the bonnet leading edge height and bumper lead.

8.3.1 Determine the Bonnet Leading Edge Height (Section 2.13) and the Bumper Lead (Section 2.12) at each impact point. These can be simply calculated using the previously

³ The foam shall be 25mm thick ConforTM foam type CF-45

digitised co-ordinates of the bonnet leading edge location and its 'equivalent' point on the Upper Bumper Reference line (Section 4.4).

8.3.2 Determine the required impact velocity, angle and the kinetic energy for the value of Bonnet Leading Edge height and Bumper Lead found in 8.3.1 using Figures 8.1, 8.2 and 8.3.

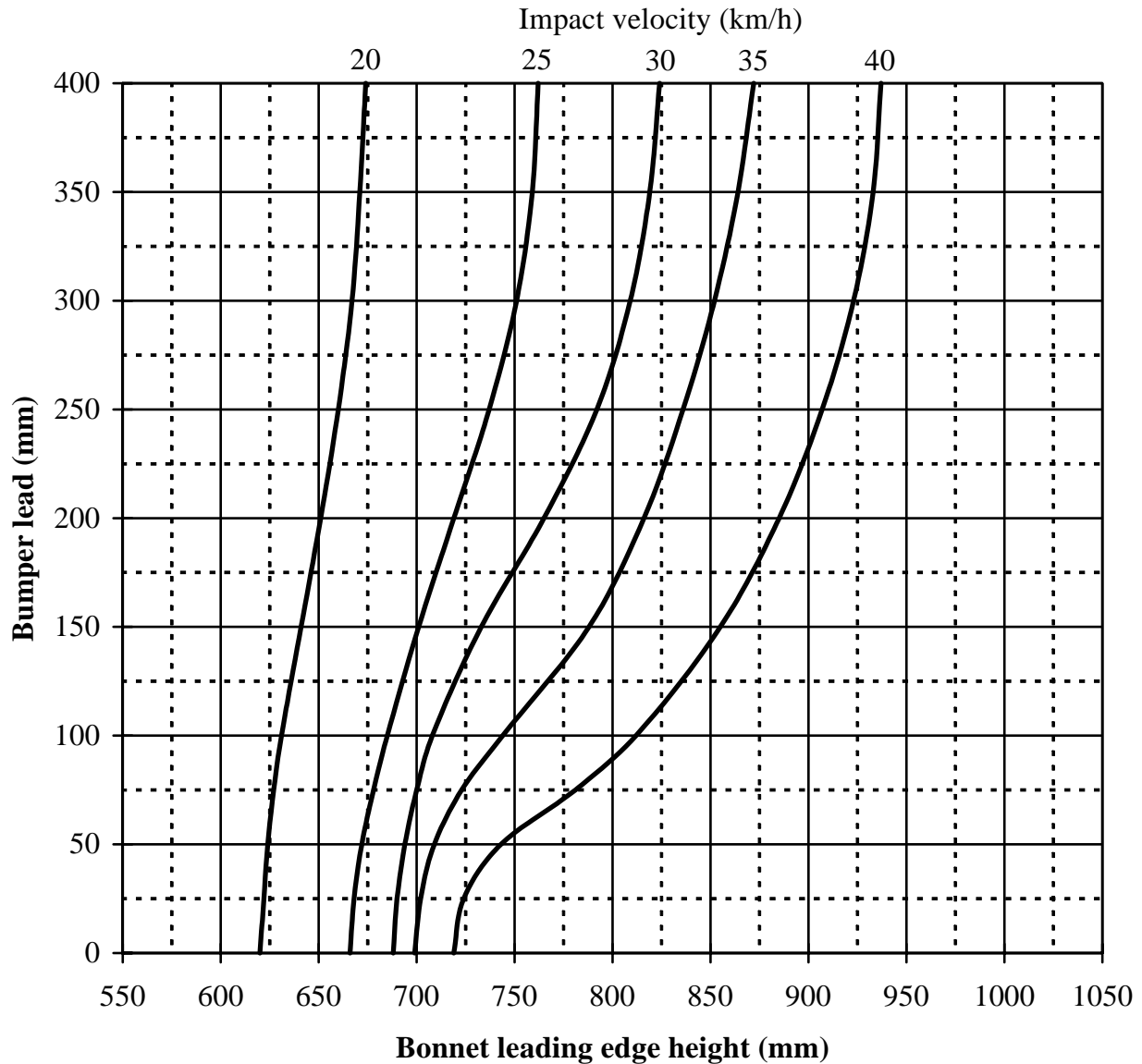

- Notes:
1. Interpolate horizontally between curves.
 2. With configurations below 20km/h - test at 20km/h.
 3. With configurations above 40km/h - test at 40km/h.
 4. With negative bumper leads - test as for zero bumper lead.
 5. With bumper leads above 400mm - test as for 400mm.

Figure 8.1

Velocity of upper legform to Bonnet Leading Edge tests with respect to vehicle shape

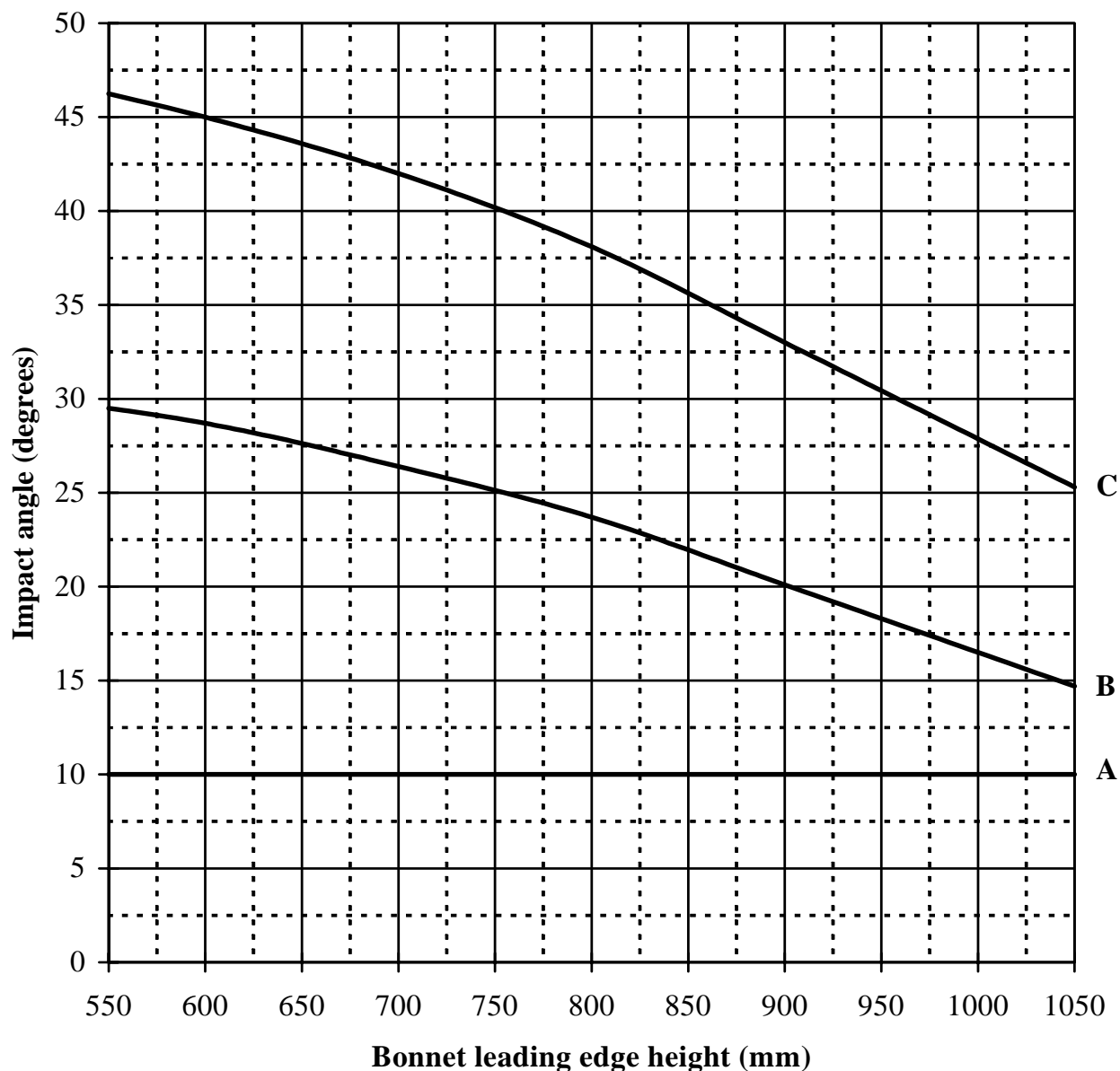

Key: A = 0mm bumper lead
 B = 50mm bumper lead
 C = 150mm bumper lead

- Notes:
1. Interpolate vertically between curves.
 2. With negative bumper leads - test as for zero bumper lead.
 3. With bumper leads above 150mm - test as for 150mm.
 4. With bonnet leading edge heights above 1050mm - test as for 1050mm.

Figure 8.2

Angle of upper legform to Bonnet Leading Edge tests with respect to vehicle shape

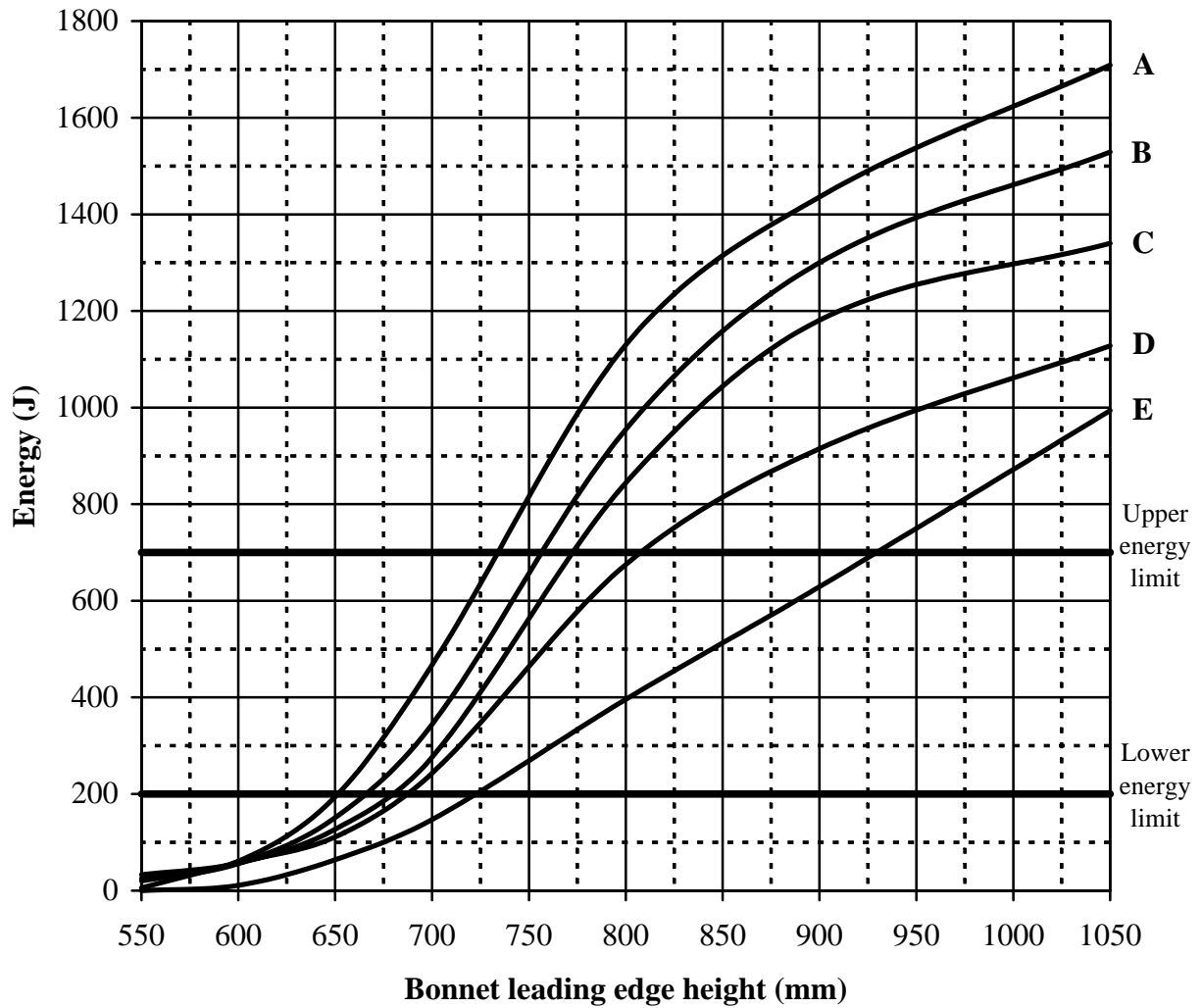

Key: A = 50mm bumper lead
 B = 100mm bumper lead
 C = 150mm bumper lead
 D = 250mm bumper lead
 E = 350mm bumper lead

- Notes:
1. Interpolate vertically between curves.
 2. With bumper leads below 50mm - test as for 50mm.
 3. With bumper leads above 350mm - test as for 350mm.
 4. With bonnet leading edge heights above 1050 mm - test as for 1050mm.
 5. With a required kinetic energy above 700J - test at 700J.
 6. With a required kinetic energy below 200J - no test is required.

Figure 8.3

Kinetic energy of upper legform to Bonnet Leading Edge tests with respect to vehicle shape

8.3.3 The total mass of the upper legform impactor includes those propulsion and guidance components which are effectively part of the impactor during the impact, including the

extra weights. Calculate the value of the upper legform impactor mass from:

$$M = \frac{2E}{V^2}$$

The upper legform impactor mass may be adjusted from the calculated value by up to $\pm 10\%$, provided the required impact velocity is also changed using the above formula to maintain the same impactor kinetic energy.

The influence of gravity on the velocity of the impactor must also be accounted for.

8.4 Test procedure - Pre-test

- 8.4.1 Ensure that the vehicle is fully test prepared as described in Section 1.
- 8.4.2 Ensure the vehicle is at the same ride heights as those recorded during marking up of the vehicle.
- 8.4.3 Ensure that the upper legform, the vehicle, the propulsion system and the data acquisition equipment has soaked in a temperature in the range of 16°C to 24°C for at least 2 hours prior to testing.
- 8.4.4 Fit a new piece of foam to the upper legform impactor from the certified sheet of foam.
- 8.4.5 Apply weights to the back of the upper legform impactor to bring the total mass up to that calculated in Section 8.3.3. Larger weights should first be applied and various smaller weights should then be added to achieve the correct weight. The upper legform impactor mass should be measured to an accuracy of better than $\pm 1\%$, and if the measured value differs from the required value then the required velocity should be adjusted to compensate, as specified in 8.3.3.
- 8.4.6 The upper legform impactor shall be aligned such that the centre line of the propulsion system and the longitudinal axis of the impacting upper legform impactor are in the fore and aft vertical plane of the section of the vehicle to be tested. The tolerances to these directions are $\pm 2^{\circ}$. At the time of first contact the impactor centre line shall be coincident with the bonnet leading edge reference line with a $\pm 10\text{mm}$ tolerance, and laterally with the selected impact location with a tolerance of $\pm 10\text{mm}$.
- 8.4.7 Adjust the propulsion system to give the correct velocity and angle of incidence at the point of impact with the tolerance on the impact velocity being $\pm 2\%$. The effect of gravity shall be taken into account when the impact velocity is obtained from measurements taken before the first point of contact. The velocity measuring device should be able to measure to an accuracy of at least $\pm 0.02\text{m/s}$. The effect of gravity shall be taken into account when the impact velocity is obtained from measurements taken before the point of first contact. The tolerance on impact direction $\pm 2^{\circ}$.
- 8.4.8 Roll the vehicle forwards to give the desired distance, so that the impactor strikes the vehicle after it has been accelerated to the test speed and so that any end stops on the guidance system do not interfere with its interaction with the vehicle. See Figure 8.4.
- 8.4.9 Fire the propulsion system.

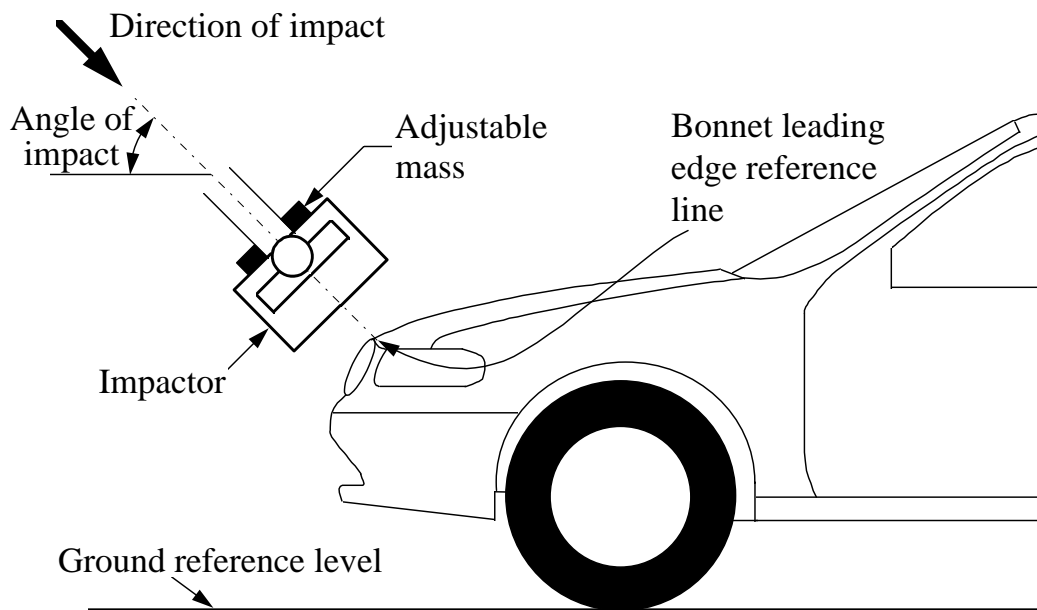

Figure 8.4
Upper Legform to Bonnet Leading Edge Test

8.5 Test Procedure - Post Test

- 8.5.1 Take at least two still photographs of the resultant dent, one from the side and one from the front. Each photograph shall have some means of identifying the vehicle and test location. The preferred method shall be to use unique run numbers for each test.
- 8.5.2 Additional photographs may be required for an individual test at the Project Managers discretion.
- 8.5.3 Check that no CAC has been exceeded before conducting the next test, if this has occurred then the impactor must be re-certified before the next test.
- 8.5.4 Replace any damaged part of the vehicle which would affect the results of the next test with new parts according to Section 5.3.
- 8.5.5 Repeat procedure for the next impact location.

9 HEADFORM TESTING

9.1 Description of Headforms and Their Instrumentation

9.1.1 The headforms used shall conform to that specified in EEVC WG17 Report, 'Improved Test Methods to Evaluate Pedestrian Protection Afforded by Passenger Cars', December 1998. The projected points for the adult headform impactor shall be a minimum of 82.5mm inside the Side Reference Lines (Section 2.5), and a minimum of 165mm apart. The projected points for the child headform impactor shall be a minimum of 65mm inside the Side Reference Lines (Section 2.5), and a minimum of 130mm apart. These minimum distances are to be set with a flexible tape held tautly along the outer surface of the vehicle. Where testing on an A-pillar is involved the minimum distance inside the Side Reference Lines does not apply to either the adult or child headform tests.

9.1.2 Instrumentation

Location	Measurement	CFC	CAC	No of channels
Centre of gravity of headform	Fore/Aft acceleration ⁴	1000	500g	1
Centre of gravity of headform	Vertical acceleration	1000	500g	1
Centre of gravity of headform	Lateral acceleration	1000	500g	1

9.2 Certification - Dynamic

9.2.1 The certification procedures are detailed in EEVC Working Group 17, 'Proposal for methods to evaluate pedestrian protection for passenger cars', Annex VII.

[This document will follow subsequent changes to the certification procedure detailed above on any levels set provisionally. The Dynamic certification procedures are under review by WG17 at present. Until this review is complete the instructions of the impactor manufacturer should be followed.]

9.2.2 The headforms⁶ shall be certified before the test programme.

9.2.3 The headforms⁶ shall be certified after a maximum of 20 impacts.

9.2.4 The headforms⁶ shall be certified at least once every 12 months regardless of the number of impacts they have undergone.

9.2.5 If the headforms⁶ exceed any of their CACs then they shall be re-certified.

9.3 Test Procedure - Pre Test

9.3.1 Ensure that the vehicle is fully test prepared as described in Section 1.

9.3.2 Ensure the vehicle is at the same ride heights as those recorded during marking up of the vehicle.

⁴ Relative to the direction of motion of the headform

⁶ Headforms consist of headskins, aluminium sphere and instrumentation

- 9.3.3 Ensure that the headforms, the vehicle, the propulsion system and the data acquisition equipment have soaked in a temperature in the range of 16°C to 24°C for at least 2 hours prior to testing.
- 9.3.4 Fit the required headform to the propulsion system. A child headform impactor shall be used for tests to the forward section of the bonnet top, A-pillars, windscreen, roof (labelled C in Section 2.9), with the points of first contact lying between boundaries described by wrap around distances of 1000mm and 1500mm. An adult headform impactor shall be used for tests to the rearward section of the bonnet top (labelled A in Section 2.9), with the points of first contact lying between boundaries described by wrap around distances of 1500 mm and 2100 mm.
- 9.3.5 Roll the vehicle forwards to give the desired free flight distance.
- 9.3.6 Adjust the propulsion system so that it can fire the headform at the injurious point with the correct angle of incidence and is aimed at the impact point.
- 9.3.7 The direction of impact shall be in the fore and aft vertical plane of the section of the vehicle to be tested. The tolerance for this direction is $\pm 2^\circ$. The direction of impact of tests to the bonnet top shall be downward and rearward, as if the vehicle were on the ground. The angle of impact for tests with the child headform impactor shall be $50^\circ \pm 2^\circ$ to the Ground Reference Level. For tests with the adult headform impactor the angle of impact shall be $65^\circ \pm 2^\circ$ to the Ground Reference Level. The effect of gravity shall be taken into account when the impact angle is obtained from measurements taken before the time of first contact.
- 9.3.8 At the time of first contact, the point of first contact of the headform impactor shall be within a ± 10 mm tolerance to the selected impact location.
- 9.3.9 Set the speed control on the propulsion system to give a velocity of 11.1 ± 0.2 m/s at the point of first contact. The velocity measuring device should be able to measure to an accuracy of at least ± 0.02 m/s. The effect of gravity shall be taken into account when the impact velocity is obtained from measurements taken before the point of first contact.
- 9.3.10 Fire the propulsion system.

9.4 Test Procedure - Post Test

- 9.4.1 Take at least two still photographs of the resultant dent, one from the side and one from the front. Each photograph shall have some means of identifying the vehicle and test location. The preferred method shall be to use unique run numbers for each test.
- 9.4.2 Additional photographs may be required for an individual test at the Project Manager's discretion.
- 9.4.3 Check that no CAC has been exceeded before conducting the next test, if this has occurred then the impactor must be re-certified before the next test.
- 9.4.4 Replace any damaged part of the vehicle which would affect the results of the next test with new parts according to Section 5.3
- 9.4.5 Repeat procedure for the next impact location.

Where a specified requirement has not been met, EuroNCAP reserves the right to decide whether or not the test will be considered as valid.

10 INJURY PARAMETERS

10.1 General

10.1.1 Any breakages or other damage of the body form impactors caused by the severity of the impact shall be recorded.

10.1.2 All data channels shall be filtered at their specified Channel Frequency Class

10.2 Limits

10.2.1 The table below lists the various injury criteria used in the pedestrian tests

Body form Impactor	Injury criterion	Limit	Method of calculation
Legform	Knee bending angle	15°	see 10.2.2
	Knee shear displacement	6mm	see 10.2.3
	Upper tibia acceleration	150g	Maximum Value
Upper legform	Sum of Impact forces	5kN	See 10.2.4
	Bending moment	300Nm	Maximum Value
Child Headform	Head Injury Criterion	1000	See 10.2.5
Adult Headform	Head Injury Criterion	1000	See 10.2.5

10.2.2 Calculation of Knee Bending Angle

10.2.2.1 Channel required: rotational transducer in the tibia

10.2.2.2 The units of radians shall be used in the following formula:

$$\text{Instantaneous Bending Angle} = \theta(t) + \text{Sin}^{-1}(1.3678 * \text{Sin } \theta(t))$$

where $\theta(t)$ is the angle that the transducer measures.

Note: The value of 1.3678 in the above equation is the ratio of lengths in the knee. These lengths shall be checked before testing begins

10.2.3 Calculation of Knee Shear displacement

10.2.3.1 Channel required: rotational transducer in the femur

10.2.3.2 Units of radians and millimetres are used in the following formula:

$$\text{Instantaneous Shear Displacement} = \text{Sin } \phi(t) \times 27.5$$

where $\phi(t)$ is the angle that the transducer measures

Note: The value of 27.5 in the above formula is a measured length and shall be checked before any testing begins

10.2.4 Calculation of Sum of Impact forces

10.2.4.1 Channels required: Load transducer at the top of the femur
Load transducer at the bottom of the femur

10.2.4.2 Units of kN are used in the following formula:

$$\text{Instantaneous sum of impact forces } F(t) = F_t(t) + F_b(t)$$

where $F_t(t)$ is the instantaneous value of the top load transducer

$F_b(t)$ is the instantaneous value of the bottom load transducer

10.2.5 Calculation of the Head Injury Criterion

10.2.5.1 Channels required: Fore/aft acceleration
Vertical acceleration
Lateral acceleration

10.2.5.2 Units of g are used in both of the following formulae

$$\text{Resultant Acceleration } A_R = \sqrt{A_x^2 + A_y^2 + A_z^2}$$

10.2.5.3 Calculate the resultant head acceleration according to:

Where A_x is the instantaneous acceleration in the Fore/Aft direction

A_y is the instantaneous acceleration in the Vertical direction

A_z is the instantaneous acceleration in the Lateral direction

10.2.5.4 Calculate the Head Injury Criterion (HIC) according to:

$$\text{HIC} = (t_2 - t_1) \left[\frac{\int_{t_1}^{t_2} A_R \cdot dt}{(t_2 - t_1)} \right]^{2.5}$$

Values for HIC for which the time interval $(t_2 - t_1)$ is greater than 15 ms are ignored for calculating the maximum value.