

15 January 2014

---

## **Global Registry**

**Created on 18 November 2004, pursuant to Article 6 of the Agreement concerning the establishing of global technical regulations for wheeled vehicles, equipment and parts which can be fitted and/or be used on wheeled vehicles (ECE/TRANS/132 and Corr.1) done at Geneva on 25 June 1998**

### **Addendum 14: Global technical regulation No. 14**

#### **Global technical regulation on on pole side impact**

Established in the Global Registry on 13 November 2013



UNITED NATIONS



## Global technical regulation on Pole Side Impact

### Contents

	<i>Page</i>
I. Statement of technical rationale and justification .....	4
A. Introduction and procedural background .....	4
B. The safety concern .....	5
C. Existing regulations and international voluntary standards .....	12
D. World Side Impact Dummy (WorldSID).....	14
E. Key elements of the gtr .....	15
F. Regulatory impact and economic effectiveness .....	28
G. Summary of issues to be considered in the second phase .....	34
H. Leadtime.....	34
II. Text of the Regulation.....	35
1. Purpose.....	35
2. Application and scope.....	35
3. Definitions.....	35
4. Requirements.....	36
 Annexes	
1 Dynamic pole side impact test procedure.....	38
2 Seat adjustment and installation requirements for the WorldSID 50 <sup>th</sup> percentile adult male dummy .....	43
3 Description of the three-dimensional H-Point machine.....	53
4 Impact reference line.....	56
5 Impact angle.....	57
6 Pitch and roll angle references.....	58
7 Determination of WorldSID 50 <sup>th</sup> percentile adult male performance criteria .....	59

## I. Statement of technical rationale and justification

### A. Introduction and procedural background

1. At the 150<sup>th</sup> session of the World Forum for Harmonization of Vehicle Regulations (WP.29) in March 2010, the representative from Australia introduced Informal document WP.29-150-11, proposing the development of a global technical regulation (gtr) on pole side impact. There were five key elements to this proposal, namely that:

- (a) A high number of fatalities occurred in pole side impacts (that is, impacts with narrow objects such as telegraph poles, signposts and trees) and other side impacts in Australia and other countries;
- (b) There was wide variation between side and pole side crash tests both in regulations and voluntary standards;
- (c) There was wide variation between the crash dummies being used in the crash tests and concerns over their biofidelity, raising concerns about their effectiveness in predicting real world injury outcomes;
- (d) The development of the WorldSID<sup>1</sup> 50<sup>th</sup> percentile adult male dummy, with its superior biofidelity, provided a unique opportunity to improve the international crash test regime for side impacts through development of a gtr on pole side impact, thereby improving the safety of vehicle users and minimising costs to consumers and industry; and
- (e) A pole side impact standard was likely to produce benefits for side impacts generally by driving improvements in head protection.

2. The Executive Committee of the 1998 Agreement (AC.3) requested the secretariat of WP.29 to distribute WP.29-150-11 with an official symbol for consideration and vote at its June 2010 session. It was agreed to transmit WP.29-150-11 to the Working Party on Passive Safety (GRSP) to consider at its May 2010 session and to assess the need for establishing an informal working group.

3. At its forty-seventh session in May 2010, GRSP considered an official proposal made by the expert from Australia (ECE/TRANS/WP.29/2010/81) together with a further informal document (GRSP-47-28), which included a proposed task list (subsequently developed into terms of reference), and endorsed the establishment of an informal working group under the chairmanship of Australia, subject to the consent of AC.3.

4. At the 151<sup>st</sup> session of WP.29 in June 2010, AC.3 considered an official proposal tabled by the representative from Australia and agreed to develop the gtr and to establish the informal working group. AC.3 also agreed that the initial tasks of the informal working group should be to:

- (a) Confirm the safety need for a gtr in light of the increasing prevalence of electronic stability control in the vehicle fleet; and
- (b) Simultaneously assess potential candidate crash test standards to be addressed by the proposed gtr. The proposal was included in the list of proposals for developing gtrs, adopted by AC.3 (ECE/TRANS/WP29/AC.3/28).

---

<sup>1</sup> World Side Impact Dummy

5. In subsequent major developments at the 154<sup>th</sup> session of WP.29 in June 2011, AC.3 adopted the terms of reference of the informal working group and its first progress report (ECE/TRANS/WP.29/2011/87).
6. At the 157<sup>th</sup> session of WP.29 in June 2012, AC.3 adopted the second progress report of the informal working group, together with a change to the terms of reference of the informal working group to clearly provide for a second phase of the development of the gtr to incorporate the WorldSID 5<sup>th</sup> percentile adult female (ECE/TRANS/WP.29/2012/59).
7. At the fifty-first session of GRSP in May 2012, the informal working group submitted an initial draft of part II of the gtr (GRSP-51-16). At the fifty-second session of GRSP in December 2012, the informal working group submitted an initial draft of Part I and a further developed draft of Part II of the gtr (GRSP-52-07).
8. In developing the gtr, the informal working group has undertaken a significant programme of work including:
- (a) Review of previous work, particularly the work undertaken on side impact protection by: the International Harmonised Research Activities (IHRA) Side Impact Working Group; the European Enhanced Vehicle Safety Committee (EEVC); the Advanced Protection Systems (APROSYS) research programme; and the United States of America, including its Final Regulatory Impact Analysis to amend Federal Motor Vehicle Safety Standard No. 214 (FMVSS 214) to add an oblique pole side impact test, published in 2007;
  - (b) Conduct of extensive primary research, including crash tests programmes conducted by Australia and Canada (including jointly), France, Japan, the Republic of Korea and the United States of America. This research has been the subject of detailed reporting in informal working group meetings and is available on the informal working group's website at: [www2.unece.org/wiki/pages/viewpage.action?pageId=3178630](http://www2.unece.org/wiki/pages/viewpage.action?pageId=3178630);<sup>2</sup>
  - (c) Consideration of work by the informal working group on the harmonization of side impact dummies (see Section D below for more detail); and
  - (d) Commissioning of research, through Australia, by the Monash University Accident Research Centre (MUARC) on the safety need, effectiveness and benefits and costs of the gtr.<sup>3</sup>

## B. The safety concern

9. The passive safety countermeasures expected to be used in vehicles to meet the requirements of the gtr on pole side impact (most likely side curtain airbags and thorax airbags) are likely to reduce injury risk in pole side impact crashes as well as other side impact crashes, including high severity vehicle-to-vehicle side impact crashes and/or crashes where head injury risks not simulated by current regulatory barrier tests occur as a result of geometric incompatibility between vehicles. It was recognised in framing the informal working group's terms of reference that there may also be benefits in rollover crashes.

<sup>2</sup> Papers from the informal working group's meetings are cited throughout this document in the format PSI-x-y, where x is the meeting number and y the reference number of the paper on the website. Reference Documents from the first meeting of the informal working group are abbreviated RD.

<sup>3</sup> Fitzharris et al, Assessment of the need for, and the likely benefits of, enhanced side impact protection in the form of a Pole Side Impact Global Technical Regulation, MUARC (2013). This report was largely based on Australian data, but with the cooperation of the UK Department for Transport, the Transport Research Laboratory and BASt also included analysis of UK and German data.

10. As a primary task, the informal working group undertook a substantial amount of research on the number of occupant fatalities and serious injuries in pole side impacts, other side impacts and rollover crashes in Contracting Parties. High level 2009 calendar year data is presented in Table 1.

Table 1  
**Fatalities and injuries in Pole Side Impacts (PSI), other side impacts and rollovers, 2009**

<i>Country</i>	<i>Population Million</i>	<i>Total road fatalities</i>	<i>4-wheeled vehicle occupant fatalities</i>	<i>PSI fatalities</i>	<i>Other side impact fatalities</i>	<i>Rollover fatalities</i>	<i>Total serious injuries</i>	<i>4-wheeled vehicle occupant serious injuries</i>	<i>PSI serious injuries</i>	<i>Other side impact serious injuries</i>	<i>Rollover serious injuries</i>
<b>Australia</b>	21.8	1 507	1 049	155	152	208	69 709	48 162	1 640	5 190	2 517
% of total road fatalities/si				10.29%	10.09%	13.80%			2.35%	7.45%	3.61%
% of 4-wheel occupant fatalities/si				14.78%	14.49%	19.83%			3.41%	10.78%	5.23%
Per 100,000		6.92	4.82	0.71	0.70	0.96	320.08	221.14	7.53	23.83	11.56
<b>Canada</b>	32.9	2 217	1 513	60	215	203	11 501	7 671	161	720	835
% of total road fatalities/si				2.71%	9.70%	9.16%			1.40%	6.26%	7.26%
% of 4-wheel occupant fatalities/si				3.97%	14.21%	13.42%			2.10%	9.39%	10.89%
Per 100,000		6.73	4.59	0.18	0.65	0.62	34.92		0.49	2.19	2.54
<b>France</b>	64.5	4 273	2 399	181	333	201	33 323	15 191	325	1 474	877
% of total road fatalities/si				4.24%	7.79%	4.70%			0.98%	4.42%	2.63%
% of 4-wheel occupant fatalities/si				7.54%	13.88%	8.38%			2.14%	9.70%	5.77%
Per 100,000		6.63	3.72	0.28	0.52	0.31	51.67	23.55	0.50	2.29	1.36
<b>Germany</b>	82.0	4 152	2 318	396	632	53	68 567	32 443	2 372	10 893	921
% of total road fatalities/si				9.54%	15.22%	1.28%			3.46%	15.89%	1.34%
% of 4-wheel occupant fatalities/si				17.08%	27.26%	2.29%			7.31%	33.58%	2.84%
Per 100,000		5.06	2.83	0.48	0.77	0.06	83.62	39.56	2.89	13.28	1.12
<b>Great Britain</b>	60.0	2 222	1 123	122	353	255	24 690	10 965	484	3 769	1 668
% of total road fatalities/si				5.49%	15.89%	11.48%			1.96%	15.27%	6.76%

<i>Country</i>	<i>Population Million</i>	<i>Total road fatalities</i>	<i>4-wheeled vehicle occupant fatalities</i>	<i>PSI fatalities</i>	<i>Other side impact fatalities</i>	<i>Rollover fatalities</i>	<i>Total serious injuries</i>	<i>4-wheeled vehicle occupant serious injuries</i>	<i>PSI serious injuries</i>	<i>Other side impact serious injuries</i>	<i>Rollover serious injuries</i>
% of 4-wheel occupant fatalities/si				10.86%	31.43%	22.71%			4.41%	34.37%	15.21%
Per 100,000		3.70	1.87	0.20	0.59	0.43	41.15	18.28	0.81	6.28	2.78
<b>Japan</b>	127.5	5 772	1 778	37	287	11	52 892	14 474	52	2 131	63
% of total road fatalities/si				0.64%	4.97%	0.19%			0.10%	4.03%	0.12%
% of 4-wheel occupant fatalities/si				2.08%	16.14%	0.62%			0.36%	14.72%	0.44%
Per 100,000		4.53	1.39	0.03	0.23	0.01	41.48	11.35	0.04	1.67	0.05
<b>Netherlands</b>	16.5	644	316	21	57	N/A	1,513	415	22	79	N/A
% of total road fatalities/si				3.26%	8.85%				1.45%	5.22%	
% of 4-wheel occupant fatalities/si				6.65%	18.04%				5.30%	19.04%	
Per 100,000		3.91	1.92	0.13	0.35		9.18		0.13	0.48	
<b>Republic of Korea</b>	48.6	5 870	1 978	204	1 024	190	126 378	251 964	1 985	148 442	1 987
% of total road fatalities/si				3.48%	17.44%	3.24%			N/A	N/A	N/A
% of 4-wheel occupant fatalities/si				10.31%	51.77%	9.61%			0.79%	58.91%	0.79%
Per 100,000		12.08	4.07	0.42	2.11	0.39		518.37	4.08	305.39	4.09
<b>USA</b>	307.0	33 808	23 885	1 371	4 872	8 794	216 769	166 734	3 813	45 695	29 894
% of total road fatalities/si				4.06%	14.41%	26.01%			1.76%	21.08%	13.79%
% of 4-wheel occupant fatalities/si				5.74%	20.40%	36.82%			2.29%	27.41%	17.93%
Per 100,000		11.01	7.78	0.45	1.59	2.86	70.61	54.31	1.24	14.88	9.74

*Notes:* 1. si = serious injuries. Definitions of serious injury vary significantly between countries. Definitions for individual countries are noted below. 2. The vehicle categories for which data was able to be provided varied between countries. The vehicle category for which countries were most commonly able to provide data was '4-wheeled vehicles'. Data has therefore been presented in the table for 4-wheeled vehicles where possible. Where not possible, this has been noted for the countries concerned. 3. Notes on data provided by each country: **Australia** - Australian fatality figures are estimates based on data from the states of Victoria and Queensland. Serious injury figures are estimates based on hospital admissions in Victoria. **Canada** - Fatality and serious injury figures include estimates for two provinces. Figures for pole side and other side impacts and rollovers are for M<sub>1</sub> and N<sub>1</sub> vehicles only, so percentages and rates may therefore be understated. Serious injury figures are for Abbreviated Injury Scale (AIS) 3+ injuries. **France** - Serious injury figures are for AIS3+ injuries. **Germany** - Population is at 31 December 2008; seriously injured figures represent persons who were immediately taken to hospital for inpatient treatment (of at least 24 hours); figures for pole side and other side impacts and rollovers are for M<sub>1</sub> vehicles only. Percentages of occupant fatalities may therefore be understated. **Great Britain** - Figures do not include Northern Ireland. The serious injury definition used is: An injury for which a person is detained in hospital as an "in patient", or any of the following injuries whether or not they the sufferer is detained in hospital: fractures, concussion, internal injuries, crushing, burns (excluding friction burns), severe cuts, severe general shock requiring medical treatment and injuries causing death 30 or more days after the accident. An injured casualty is recorded as seriously or slightly injured by the police on the basis of information available within a short time of the accident. This generally will not reflect the results of a medical examination, but may be influenced according to whether the casualty is hospitalised or not. Hospitalisation procedures will vary regionally. **Japan** - Figures for pole side impacts do not include impacts with trees, which are included among other side impacts. Serious injuries are injuries requiring 30 days or more for recovery. Figures for pole side and other side impacts and rollovers are for vehicles up to and including 3.5 tonnes, so percentages and rates may therefore be understated. **Netherlands** - Figures for pole side and other side impacts and rollovers are for M<sub>1</sub> vehicles and N<sub>1</sub> (delivery vans only). Percentages of occupant fatalities may therefore be understated. Figures are not available for rollovers. Serious injury figures are for AIS3+ injuries. **Republic of Korea** - The definition for total serious injuries is more than 3 weeks treatment in hospital; the figures for 4-wheeled vehicle occupant serious injuries, pole and other side impact serious injuries and rollover injuries comprise all reported injuries. Percentages of total serious injuries are therefore not available. **United States** - Serious injury figures are estimates of incapacitating injuries.

11. In the nine countries for which data was provided, in 2009 an average of 5 per cent of the road toll was killed in pole side impacts and 12 per cent of the road toll was killed in other side impacts, representing an average of 9 and 23 per cent of vehicle occupant fatalities respectively.

12. Assessment of the scale of serious injuries arising from pole side impacts and other side impacts is more difficult as definitions of serious injury have varied between the countries providing data and the figures provided in Table 1 should accordingly be treated with caution.

13. However, data from Canada, France and the Netherlands indicates a range of 1.0 to 2.6 AIS3+ injuries for every pole side impact fatality in those countries and 1.4 to 4.4 AIS3+ injuries for every other side impact fatality. Data from the Republic of Korea indicates that 9.7 injuries were reported for every pole side impact fatality and 145 injuries were reported for every other side impact.

14. These figures indicate the very large numbers of injuries associated with side impacts reinforcing the safety need indicated by the fatality figures. Within these, it might be noted that pole side impacts are relatively uncommon as a crash type, but that they represent a disproportionately high level of fatalities and AIS3+ injuries indicating the lethal nature of pole side impacts.



15. Analysis of the cause of death or of injury types also indicates some clear patterns. For example, Table 2 shows the following breakdown of fatalities in Australia in the period 2001-2006.

Table 2

**Australian coroner ruled causes of death for occupants of Category 1-1 and Category 2 (up to 3.5t Gross Vehicle Mass (GVM)) vehicles in frontal impact, pole side impact and other side impact crashes period, 2001-2006 inclusive**

Coroner ruled cause of death	Category 1-1 vehicles			Category 2 vehicles		
	Frontal	PSI	Side - other	Frontal	PSI	Side - other
	% of 1 071 occupants	% of 566 occupants	% of 735 occupants	% of 201 occupants	% of 50 occupants	% of 60 occupants
Head	43.1%	54.1%	47.3%	41.8%	56.0%	53.3%
Face	13.4%	10.1%	5.9%	6.5%	8.0%	10.0%
Neck	8.5%	8.3%	9.4%	7.5%	4.0%	10.0%
Thorax	41.8%	36.2%	43.1%	43.3%	38.0%	41.7%
Abdominal/ Pelvic	21.8%	25.3%	26.3%	25.4%	22.0%	21.7%
Spine	10.3%	7.6%	10.7%	7.5%	6.0%	13.3%
Upper extremity	9.8%	10.6%	7.5%	14.9%	16.0%	8.3%
Lower extremity	16.1%	11.1%	9.0%	18.4%	10.0%	8.3%
External	4.5%	1.8%	1.4%	6.5%	4.0%	Nil
Multiple	35.9%	37.1%	36.1%	41.3%	46.0%	36.7%
Injury NFS	3.2%	2.7%	2.4%	1.0%	Nil	Nil

*Source:* Fitzharris et al, p 64. Fatalities frequently involved lethal injuries to multiple parts of the body. Where specified as 'multiple', no specific region was provided. NFS = Not Further Stated.

16. Head injuries were a major cause of death for both pole side impacts and other side impacts (and notably more prevalent than in frontal impacts), followed by thorax, abdominal/pelvic and spine injuries. This statement applied to both Category 1-1 and Category 2 vehicles, although percentages varied between the two categories (for example head injuries were more common as a cause of death for Category 2 vehicles).

17. Analysis of AIS1+ and AIS3+ injuries in Table 3 shows somewhat different patterns. Thorax injuries are the major cause of AIS3+ injury for both pole side impacts and other side impacts, followed by head, abdominal/pelvic and spine injuries (reflecting the fact that head injuries are more likely to be fatal).

Table 3  
**Injuries sustained (period 2000-2010 inclusive) by struck-side occupants of Category 1-1 vehicles (model year 2000 or later vehicles) in Victoria, Australia**

AIS body region	AIS1 +				AIS3+			
	PSI		Vehicle		PSI		Vehicle	
	N	%	N	%	N	%	N	%
Head	121	57.1%	321	37.1%	25	11.8%	48	5.5%
Face	45	21.2%	70	8.1%	Nil	Nil	Nil	Nil
Neck	2	0.9%	3	0.3%	Nil	Nil	Nil	Nil
Thorax	76	35.8%	276	31.9%	45	21.2%	75	8.7%
Abdomen-pelvis	80	37.7%	281	32.5%	14	6.6%	17	2.0%
Spine	63	29.7%	286	33.1%	3	1.4%	6	0.7%
Upper extremity	107	50.5%	294	34.0%	2	0.9%	Nil	Nil
Lower extremity	67	31.6%	213	24.6%	18	8.5%	11	1.3%

*Source:* Fitzharris et al, p. 83. The table uses insurance claims data from the Australian state of Victoria for vehicle models dated 2000 or later (that is, after Regulation No. 95 was mandated) for the period 2000-2010. The number of vehicle-to-vehicle crashes was 865 and pole side impacts 212.

18. These figures will be relevant in considering the injury criteria for the gtr set out below. However, the prevalence of head injury in both pole side impacts and other side impacts is also important in that it both underlines safety need and is relevant to assessment of benefits. In Australia, for example, the most recent value of a statistical life is Australian dollars A\$ 4.9 Million <sup>4</sup> (US\$ 5.1 Million).<sup>5</sup> Based on insurance claims data, it has been estimated that the societal and lifetime care cost of severe brain injury (taken to be AIS4+) is A\$ 4.8 Million and moderate brain injury (taken to be AIS3) is A\$ 3.7 Million. <sup>6</sup>

## 1. Category 2 vehicles

19. In general the majority of data provided in Table 1 relates either to Category 1 vehicles or has not been disaggregated by vehicle category. This makes assessment of safety need more difficult for Category 2 vehicles than it is for Category 1.

20. In the United States of America, the Final Regulatory Impact Analysis, to add an oblique pole side impact test (published in 2007), aggregated data for Category 1 and Category 2 vehicles. The test applies to Category 1 and Category 2 vehicles (which commonly includes pick-ups), with some exceptions.

<sup>4</sup> A\$ is an abbreviation for Australian Dollars.

<sup>5</sup> Fitzharris et al, p 134. Conversion was at 5 February 2013.

<sup>6</sup> Fitzharris et al, p 134.

21. Australia presented data to various meetings of the informal working group that indicated that as a proportion of Category 2 vehicle fatalities (up to 3.5t GVM), pole side impacts and other side impacts were approximately as common as they were among Category 1-1 vehicles (PSI-01-07; PSI-04-06; PSI-06-07). However, the large majority of fatalities and serious injuries in Category 2 vehicles (up to 3.5t GVM) in Australia involve passenger derived utility vehicles, 4X2 pick-ups/cab chassis utility vehicles and 4X4 pick-ups/cab chassis utility vehicles.

22. These vehicles are increasingly being used as passenger vehicles and in many cases are exempt from the requirements of Regulation No. 95 as their seating reference height is over 700 mm.

23. At the eighth meeting of the informal working group, France presented a comparative assessment of the benefits from a pole side impact test for Category 1-1 and Category 2 vehicles (up to 3.5t GVM) (PSI-08-10). The benefit-cost ratio for the Category 1-1 vehicles was significantly higher than for the Category 2 vehicles, indicating that application of the gtr to Category 2 vehicles in France would not be justified.

24. The French and Australian data highlights the fact that the composition of vehicle fleets, and therefore safety need, among Category 2 vehicles is likely to be highly variable from country to country. This matter will be considered further when the applicability of the gtr is considered in Section E below.

## 2. Electronic Stability Control

25. The informal working group considered the extent to which the safety concern associated with pole side impacts and other side impacts would be addressed by the advent of Electronic Stability Control (ESC). ESC will substantially improve vehicle stability and braking performance and consequently assist in avoiding impacts or reducing the impact speed if an impact is unavoidable.

26. In this regard, the informal working group noted that the fitment of ESC to vehicles had recently increased significantly. For example, in Europe ESC will become mandatory for almost all Category 1, Category 1-2 and Category 2 vehicles by 2013. The group also considered research presented by the Federal Highway Research Institute (BASt), the National Highway Traffic Safety Administration (NHTSA) and MUARC, showing the following crash reductions:

- (a) BASt –overall effectiveness of ESC in reducing fatally and severely injured drivers assuming an ESC equipment rate of 100 per cent of the vehicle fleet – about 40 per cent (PSI-01-08);
- (b) NHTSA - single vehicle run-off-crashes: 35 per cent for passenger cars; 67 per cent for sports utility vehicles (preventing 41 per cent of fatal crashes and 35 per cent of serious injuries) (PSI-01-16); and
- (c) MUARC: single vehicle crash reductions: 24 per cent for passenger cars; 54 per cent for four-wheel drive Category 1-1 vehicles and 45 per cent for Category 2 vehicles (up to 3.5t GVM).<sup>7</sup>

27. These are significant figures, but even where ESC is fitted or will be fitted, this will still leave a large proportion of pole side impacts to be addressed. Moreover, ESC is much less effective in multi-vehicle crashes which make up the majority of all side impacts. MUARC's recent research indicates negligible or no benefits.<sup>8</sup> Calculations of the effectiveness of ESC should also take into account driver factors, such as gender and age

<sup>7</sup> Fitzharris et al, pp. 126-128

<sup>8</sup> Fitzharris et al, p 127

and crash characteristics. For instance, the effectiveness of ESC may be less for younger drivers. These drivers have disproportionately high involvement in pole side impact crashes.<sup>9</sup>

28. NHTSA's Final Regulatory Impact Analysis to add an oblique pole side impact test (published in 2007) assumed 100 per cent implementation of ESC while still showing major benefits. Calculations by MUARC for Australia also show major benefits, while assuming 100 per cent implementation of ESC for Category 1 and 2 vehicles (see Section F).

29. The informal working group also considered the potential for other active safety systems, such as collision avoidance systems to reduce the fatalities and injuries occurring in side impacts. The benefits from such systems are largely yet to be established, while the proposed gtr responds to a major current safety need. Nevertheless it will be possible for Contracting Parties to consider developments in active safety when considering adoption of the gtr into domestic regulation.

### **3. Rollover crashes**

30. In Table 1 countries provided data indicating that a high proportion of road fatalities and injuries occurred in rollover crashes. While it is reasonable to assume that a portion of rollover fatalities and injuries would be avoided by the implementation of the gtr, it is not clear to what extent rollovers are associated with pole side and other side impacts. It is also not clear to what extent countermeasures generated by the gtr will address rollover injuries. The main benefit of pole side impact countermeasures in protecting vehicle occupants in a rollover is by prevention of ejection through side windows. This may only be effective in a subset of crashes as it is necessary for sensors to detect rollovers without side impact (unless the rollover is initiated by a side impact) and for the deployed curtain to cover the window area and remain in place sufficiently long to prevent ejection.

31. It might also be noted that ESC is likely to be at its most effective in countering rollovers, particularly among Category 2 vehicles. It will be for Contracting Parties to determine the extent the gtr will address fatalities and injuries in rollover crashes, in light of their own circumstances, when considering adoption of the gtr.

## **C. Existing regulations and international voluntary standards**

32. As indicated in Table 4, test procedures for pole side impact tests, either in regulation or in voluntary standards, are highly variable internationally.

---

<sup>9</sup> Fitzharris et al, p 127

Table 4  
**Current Pole Side Impact test procedures**

<i>Regulatory</i>	<i>Impact Angle</i>	<i>Impact Velocity</i>	<i>Dummy</i>	<i>Comments</i>
US FMVSS 201 <sup>10</sup>	90°	24 to 29 km/h	SID-H3 (50 <sup>th</sup> percentile male)	Manufacturers need not perform the FMVSS 201 90° pole test if the vehicle is certified to meet FMVSS 214.
US FMVSS 214 Advanced	75°	up to 32 km/h	ES-2re <sup>11</sup> (50 <sup>th</sup> percentile male)	26-32 km/h in phase-in up to 31 August 2014; thereafter up to 32 km/h <sup>12</sup>
	75°	up to 32 km/h	SID-IIs (5 <sup>th</sup> percentile female)	26-32 km/h in phase-in up to 31 August 2014; thereafter up to 32 km/h <sup>12</sup>
<i>Voluntary Standards – New Car Assessment Programmes (NCAPs)</i>				
U.S. NCAP	75°	32 km/h	SID-IIs (5 <sup>th</sup> percentile female)	
Euro NCAP	90°	29 km/h	ES-2 (50 <sup>th</sup> percentile male)	
KNCAP	90°	29 km/h	ES-2 (50 <sup>th</sup> percentile male)	
ANCAP	90°	29 km/h	ES-2 (50 <sup>th</sup> percentile male)	
JNCAP	No test			
Latin NCAP	No test			
China NCAP	No test			
ASEAN NCAP	No test			

<sup>10</sup> Optional test in lieu of 24 km/h free motion headform tests. Manufacturers opting to perform the pole test may test upper interior targets with a reduced speed (19 km/h) free motion headform test.

<sup>11</sup> ES-2 dummy with rib extensions (ES-2re).

<sup>12</sup> Some exceptions apply.

33. As this table indicates, the United States of America is the only country which has implemented a regulatory pole side impact standard. It did this first with the perpendicular test requirement in FMVSS 201 (as an alternative to upper interior headform testing where head protecting airbags are fitted) and is currently phasing in an oblique test requirement in FMVSS 214. In Europe and a number of countries outside Europe, pole side impact tests are conducted by New Car Assessment Programmes (NCAPs), although whether and how NCAPs conduct tests vary. In many member countries of WP.29 neither regulatory nor voluntary pole side impact tests operate.

## **D. World Side Impact Dummy (WorldSID)**

### **1. Biofidelity**

34. The WorldSID 50<sup>th</sup> percentile adult male dummy (WorldSID 50<sup>th</sup> male) was developed by government and industry organizations and has demonstrated improved overall biofidelity when compared to the current test tools used in side impact testing. The WorldSID 50<sup>th</sup> male's expanded capability includes an improved shoulder range of motion and displacement measurement, more human-like shoulder and thorax motion, improved external oblique biofidelic response, and abdominal displacement measurement capability.

35. Currently the EuroSID 2 (ES-2) 50<sup>th</sup> percentile adult male dummy is used in pole side impact testing by a number of NCAPs, while the ES-2re 50<sup>th</sup> percentile adult male dummy is specified for use in the FMVSS 214 pole side impact test. However, both the WorldSID taskforce and NHTSA have conducted research that has shown the WorldSID 50<sup>th</sup> male to be considerably more biofidelic than the ES-2 and ES-2re. On the 10 point ISO TR9790 biofidelity rating scale, the WorldSID taskforce found the WorldSID 50<sup>th</sup> male to have a rating of 8.0, the ES-2 a rating of 4.7, and the ES-2re a rating of 4.2. Furthermore, the shoulder of the ES-2 dummy has a substantially lower biofidelity rating than the WorldSID 50<sup>th</sup> male. Shoulder design substantially affects dummy response during pole and side airbag interactions, while biofidelity is extremely important in narrow object crashes as the margins between minor and serious or fatal injury are relatively small.<sup>13</sup>

36. The informal working group regards the WorldSID 50<sup>th</sup> male as having major benefits as a test tool that should translate into superior countermeasures providing real world protection. The informal working group unequivocally recommends that the first phase of the gtr use the WorldSID 50<sup>th</sup> male as the anthropomorphic test tool.

### **2. Preparing WorldSID for use as a regulatory test tool**

37. At the 151<sup>st</sup> meeting of WP.29 in June 2010, AC.3 agreed to the establishment of an informal working group on harmonization of side impact dummies chaired by the United States of America, with the primary focus of the informal working group being to ready the WorldSID dummies for use as regulatory test tools. This coincided with AC.3's agreement to the establishment of the informal working group for the gtr on pole side impact; and as intended by AC.3, the two groups have worked in close conjunction with each other.

38. At the 158<sup>th</sup> meeting of WP.29 in November 2012, AC.3 adopted a proposal for a Mutual Resolution (ECE/TRANS/WP.29/2012/124, as amended by WP.29-158-19), to manage drawings, calibration and maintenance procedures associated with test tools referenced in UN Regulations and gtrs.

---

<sup>13</sup> Further details of the biofidelity evaluations conducted by the ISO WorldSID taskforce are available in ISO 15830\_1:2013 and Enhanced Safety of Vehicles (ESV) conference paper 09-0505. The WorldSID 50<sup>th</sup> percentile adult male and ES-2re biofidelity comparison conducted by NHTSA is summarized in ESV conference paper 09-0563.

39. Addendum 2 of Mutual Resolution No. 1 (M.R.1) is reserved for the technical specifications of the WorldSID 50<sup>th</sup> male, including detailed engineering drawings, certification requirements and procedures for assembly/disassembly. Part II of the gtr therefore includes references to Addendum 2 of M.R.1. For each of these references, square brackets are used to denote that this addendum is under development and hence yet to be adopted by AC.3. It is intended that the informal working group on the Harmonization of Side Impact Dummies will seek to finalise an agreement with ISO for the availability of technical specifications of the WorldSID 50<sup>th</sup> male in Addendum 2 of M.R.1.

### **3. The two phase approach**

40. Drawings, calibration and maintenance procedures for the WorldSID 50<sup>th</sup> male are expected to be available for citation (by way of reference to a WorldSID 50<sup>th</sup> male addendum to the Mutual Resolution) in the gtr in 2013 whereas the timetable for the WorldSID 5<sup>th</sup> percentile adult female (WorldSID 5<sup>th</sup> female) to reach this stage of development appears likely to extend to 2014 or beyond.

41. As some Contracting Parties indicated an intention to transpose the gtr using the WorldSID 50<sup>th</sup> male as soon as this was practical, there was significant discussion in the informal working group over whether and how to address small occupant protection in the gtr, while recognising that it would not be possible for the United States of America to agree to a gtr that was in any way less stringent than FMVSS 214. FMVSS 214 sets test requirements for a 5<sup>th</sup> percentile adult female dummy (SID-IIs).

42. The informal working group also noted that NHTSA estimated that small occupants (5'4" or less) represented 25 per cent of all near side occupant fatalities and serious injuries in side impacts in the US in the period 2002-2004. In calculating the benefits for the amendment to FMVSS 214 to include a pole side impact test, NHTSA estimated that the use of the SID-IIs 5<sup>th</sup> percentile adult female would save an additional 78 lives a year (PSI-01-10).

43. As a consequence the informal working group agreed to a two phase approach to the gtr, subsequently endorsed by GRSP and AC.3, to enable Contracting Parties to implement a pole side impact standard utilising the WorldSID 50<sup>th</sup> male and, if warranted, to subsequently implement a pole side impact standard utilising the WorldSID 5<sup>th</sup> female.

44. As noted in the introduction and procedural background (paragraph 6.), the terms of reference for the informal working group were amended to provide for a second phase of the development of the gtr to incorporate the WorldSID 5<sup>th</sup> female.

45. Part II of this gtr provides for the second phase of work by including place marks for future text on the WorldSID 5<sup>th</sup> female; and explicit provision for Contracting Parties to apply any pre-existing domestic pole side impact requirements for 5<sup>th</sup> percentile adult female side impact dummies, prior to the availability of the WorldSID 5<sup>th</sup> female.

## **E. Key elements of the gtr**

### **1. Application and scope**

46. The application of the requirements of this gtr refer, to the extent possible, to the revised vehicle classification and definitions outlined in the 1998 Global Agreement Special Resolution No. 1 (S.R.1) concerning the common definitions of vehicle categories, masses and dimensions.

47. The informal working group agreed to recommend a wide application in the gtr in terms of vehicle categories; specifically, that it apply to all Category 1-1 vehicles; Category 1-2 vehicles with a Gross Vehicle Mass of up to 4,500 kg; and Category 2 vehicles with a Gross Vehicle Mass of up to 4,500 kg.

48. This maximises the ability of jurisdictions to effectively address regional differences in their vehicle fleets. However, it is important to note that Contracting Parties have the discretion to exclude particular vehicle types, for which there is insufficient national safety need to justify regulation or for which the test requirement in the gtr is not feasible. If a Contracting Party determines that its domestic regulatory scheme and/or safety needs are such that full applicability is inappropriate, it may limit domestic implementation of the gtr to certain vehicle categories or mass limits. A Contracting Party could also decide to phase-in the requirements for certain vehicles. To make this clear, a footnote was added to the application and scope section of Part II to make it clear that Contracting Parties can decide to limit the applicability of the regulation. This approach recognizes that niche vehicles that are unique to a Contracting Party would best be addressed by that jurisdiction, without affecting the ability or need for other Contracting Parties to regulate the vehicles. When a Contracting Party proposes to adopt the gtr into its domestic regulations, it is expected that the Contracting Party will provide reasonable justification concerning the application of the regulation.

49. Accident statistics from some regions indicate certain vehicles, particularly cargo vehicles such as one-box vans, are rarely involved in side impacts with rigid narrow objects such as poles and trees. Furthermore, many of these vehicles also have high seating positions which are likely to reduce the exposure of occupants to injurious head and thorax impact loadings in other side impact crashes. In vehicle-to-vehicle side impact crashes the most likely sources of struck-side occupant head injuries are head contact with the bonnet/hood of a striking vehicle, head contact with the vehicle interior (for example, the b-pillar) or head-to-head contact with an adjacent occupant seated in the same seat row. Struck-side occupant thorax injuries in vehicle-to-vehicle side impacts are most likely to be caused by rapid loading of the occupant thorax by an intruding b-pillar, armrest or door trim. Occupants of vehicles with high seating reference points would be expected (by virtue of their seating height) to have reduced exposure to head-to-striking vehicle bonnet/hood contacts, as well as less exposure to high vehicle interior (such as the b-pillar or armrest) intrusion velocities at the occupant head and thorax seating level in vehicle-to-vehicle side impacts.

50. It is also understood that vans, mini-buses and mini-trucks are typically driven and used differently to normal passenger cars and pick-ups. The way in which these vans, mini-buses and mini-trucks are driven and the purposes for which they are used will influence the likelihood (risk) of these vehicles being involved in fatal and/or serious pole side impact and other side impact crashes.

51. The informal working group therefore decided to include criteria here that Contracting Parties may use, if warranted by national safety need data, to exempt certain Category 1-2 and Category 2 vehicles from the requirements of the gtr at the time of implementation in domestic regulation. These vehicles are robustly characterized as Category 1-2 and Category 2 vehicles where the angle  $\alpha$ , measured rearwards from the centre of the front axle to the R-point of the driver's seat is at least 22 degrees; and the ratio between the distance from the drivers' R-point to the centre of the rear axle (L101-L114) and the centre of the front axle and the drivers' R-point (L114) is greater than or equal to 1.3.



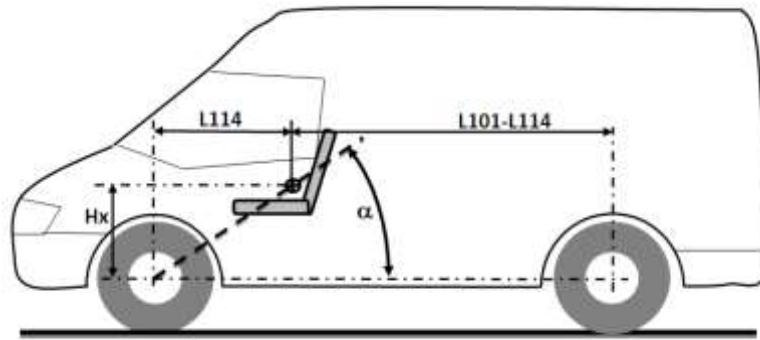

52. The expert from OICA made a presentation (PSI-07-08) at the seventh meeting of the informal working group detailing vehicle dimensions and showing how these specific measurements can accurately define vehicle types. An  $\alpha$  of at least 22 degrees was proposed because it would enable the exemption of mini-buses, vans and mini-trucks with high seating positions (that is, high seating reference points) and/or where the occupant is seated over the front axle, without exempting pick-ups. A ratio between the distance from the drivers' R-point to the centre of the rear axle (L101-L114) and the centre of the front axle and the drivers R-point (L114) greater than or equal to 1.3 was proposed because it characterises vehicles which have significant cargo space and a centre of gravity considerably rearward of the driver's R-point.

## 2. Angle of impact

53. The informal working group considered three different impact configurations for possible use in the gtr test procedure, namely:

- (a) The oblique angle currently used in the FMVSS 214 pole side impact test, with the pole aligned with the centre of gravity of the dummy head;
- (b) The perpendicular angle used by a number of NCAPs in their pole side impact tests, including EuroNCAP and Australian NCAP, with the pole aligned with the centre of gravity of the dummy head; and
- (c) A perpendicular pole side impact test procedure with the location of the pole offset 100 mm forward of the head centre of gravity.

54. The informal working group discounted configuration (c) above at an early stage as an unnecessary departure from existing procedures, with no demonstrated benefit, at a time when major change would already be required to incorporate WorldSID into a test procedure.

55. This left the informal working group to select the most appropriate configuration from a perpendicular and an oblique angle impact, aligned with the head centre of gravity. There were two primary factors in its consideration of this matter: the angle of impact in real world pole side impacts and the outcome being sought.

56. The oblique angle test emerged as the recommended test angle having regard to both criteria. US (RD02; PSI-02-14), German (PSI-03-10) and Australian (PSI-04-08) data indicated that pole side crashes occurred at predominantly oblique angles (earlier EEVC analysis indicating that 90 degree angle crashes were more common was recorded within a range of plus or minus 15 degrees and therefore not contradictory).

57. In all other respects evidence favoured an oblique angle test over a perpendicular angle test or was, at least, neutral; the oblique angle test was shown to load the WorldSID 50<sup>th</sup> male thorax better than a perpendicular test (PSI-01-15; PSI-02-09; PSI-03-03;

PSI-04-03; PSI-05-05; PSI-06-04; PSI 07-03); manufacturers indicated that the oblique test encouraged more robust sensors; previous concerns regarding repeatability were shown to be unfounded (PSI-07-03); and data was presented suggesting oblique angle impacts were likely to become more common for vehicles fitted with ESC (PSI-02-18).

58. Most importantly, an oblique angle test was also expected to produce higher head injury values in testing, drive an extended coverage area by head protecting curtain airbags and be less sensitive to seat position and seat back angle (RD02).

59. As a reflection of a number (but not all) of these points, NHTSA's Final Regulatory Impact Analysis (RD02) to add an oblique pole side impact test (published in 2007), calculated that an oblique angle test would save at least 87 more lives a year than a perpendicular angle test (PSI-03-06).

### **3. Test speed**

60. Apart from one exception described below, the gtr provides that the "test vehicle ... shall be impacted into a stationary pole at any speed up to and including 32 km/h". This wording provides the flexibility for both self-certification and type approval authorities to adopt approaches in implementing the gtr that are consistent with their normal practice. For example FMVSS 214 currently allows vehicles to be tested at a speed between 26 km/h and 32 km/h (for vehicles manufactured on or before 31 August 2014) and any speed up to and including 32 km/h (for vehicles manufactured on or after 1 September 2014). This approach will be able to be maintained under the gtr. Type approval authorities will, on the other hand, be able to specify a single test speed of 32 km/h.

61. There was some discussion within the informal working group about whether type approval authorities could determine test speeds from within a range. However, it was recognised that this could potentially mean vehicle manufacturers being required to do many different tests at different speeds in type approval markets. In contrast, to address the speed range requirements of self-certification authorities, manufacturers can use appropriate tools including simulation models to satisfy themselves they meet all potential test speeds.

62. The informal working group agreed that it would be appropriate for type approval authorities to set the test speed at 32 km/h with a tolerance of plus or minus 1 km/h as this would allow a reasonable margin either side of the maximum test speed at which Contracting Parties may require a vehicle to meet the gtr. It should be noted that this tolerance would not necessarily require manufacturers to obtain type approval for test speeds greater than 32 km/h. It simply means test speeds of 32 km/h plus or minus 1 km/h would be accepted for type approval purposes. Where test speed can be controlled more accurately, for example to within plus or minus 0.5 km/h as has been required of EuroNCAP test facilities, type approval tests could consistently be conducted within the allowable range, without manufacturers being required to demonstrate compliance in excess of the 32 km/h maximum test speed of the gtr.

### **4. Exception for narrow vehicles**

63. The exception from the requirement that the "test vehicle...shall be impacted into a stationary pole at any speed up to and including 32 km/h" is set in Annex 1, paragraph 7.2., of Part II and reads:

*"The maximum test velocity may be reduced to 26 km/h for vehicles with a width of 1.50 m or less. Contracting parties selecting this option shall notify the Secretary General in writing when submitting the notification required by section 7.2 of the Agreement Concerning the Establishing of Global Technical Regulations for Wheeled Vehicles, Equipment and Parts Which Can Be Fitted".*

64. This provision was agreed by the informal working group in response to a request from the expert from Japan to provide a temporary concession for narrow vehicles (which have a width of 1.50 m or less and are categorized as small vehicles) in the gtr. In agreeing to this concession the informal working group took the view that it was better for narrow vehicles to be brought clearly within the ambit of the gtr than be subject to exclusions to the gtr made in domestic law. In this respect the informal working group was mindful that narrow vehicles are being manufactured in other markets and are likely to become increasingly prevalent in the global market.

65. Japan made a number of points in support of its case. In PSI-05-06, for example, Japan indicated that narrow vehicles (for example, Japanese Kei-cars), tend to have speeds in single vehicle crashes lower than standard-size cars. In addition, a survey on pole side impact accidents in Japan also showed that the danger recognition speed in single vehicle crashes of Kei-cars is lower than standard-size cars by about 5 to 7 km/h around the 70<sup>th</sup> percentile range. The 26 km/h test speed covers the Kei-car accidents at a rate equivalent to that of 32 km/h for the other vehicles.

66. Moreover, in the case of narrow vehicles with a width of 1.50 m or less, since the distance between door outer panel and seat centre is short, it is difficult to meet the injury criteria for the crash speed of 32 km/h with current crash safety technologies.

67. Contracting Parties among the informal working group stressed, however, that the exemption should be removed (that is, narrow vehicles should be tested at a speed of 32 km/h) when it is technically viable for narrow cars to meet all requirements of the gtr.

68. For this reason, the exemption should be kept under regular review, including in the second phase.

69. In agreeing to the concession, the informal working group also agreed that it would be a matter for each Contracting Party to determine whether narrow vehicles tested at 26 km/h could be admitted to its market. It was noted that this principle could be reflected in transposition of the gtr into a Regulation of the 1958 Agreement.

## 5. Injury criteria

70. In formulating injury criteria for the WorldSID 50<sup>th</sup> male in this gtr, the informal working group had regard to the injury risk curves agreed by ISO Working Group 6 (ISO WG6)<sup>14</sup> for the shoulder, thorax, abdomen and pelvis adjusted for a 45-year-old male (WS-08-04; WS-09-07)<sup>15</sup>.

71. The informal working group also had regard to the comparatively young age profile of vehicle occupants in pole side impacts (various studies suggested a median age of about 24 years of age), although it was noted that the age profile of vehicle occupants in other side impacts was older (with a median age of about 45 years of age).<sup>16</sup> Setting injury criteria on the basis of injury curves adjusted for a 45-year-old provides greater protection where the demographic associated with a particular crash type is younger (and more physically robust). This should produce additional road safety benefits and be considered in benefit calculations.

<sup>14</sup> ISO/SC12/TC22/WG6 (Injury criteria), which worked in conjunction with the European Automobile Manufacturers' Association (ACEA) - Dummy Task Force, experts from universities, governmental institutions and vehicle manufacturers.

<sup>15</sup> References are to meeting papers of the informal working group on harmonization of side impact dummies. Injury risk curves developed by ISO WG6 for the evaluation of occupant protection in side impact are published periodically in ISO/TR 12350.

<sup>16</sup> Fitzharris et al, *passim*. In the Australian state of Victoria in the period 1999 to 2010, 77 per cent of all fatalities in pole side impacts were aged under 45, while 52 per cent of all fatalities in vehicle-to-vehicle side impacts were aged under 45.

72. The informal working group also noted that FMVSS 214 includes four injury criteria for the ES-2re 50<sup>th</sup> percentile male (45-year-old) in the pole side impact test, addressing head, thorax, abdominal and pelvis injury risk.

73. At the fifth meeting of the informal working group, the United States noted that while it would be in a position to agree with the injury risk curves within the timeline of the Phase 1 of this gtr, it may not be in a position to agree to injury risk values without delaying the timeline. The United States suggested that, given that benefits and costs may vary depending on the fleets of different countries, the gtr should include only the injury risk curves, with Contracting Parties to choose appropriate injury assessment reference values (IARVs) when implementing the gtr in national legislation. As stated in paragraph 32., the United States is in a unique position in having the only existing dynamic pole side impact regulation. Because of this, the United States seeks to ensure that the benefits achieved by their current pole side impact regulation are increased or, at least, maintained.

74. While the informal working group rejected the suggestion of including only the injury risk curves, it is understood that the United States will conduct a full analysis of the impacts of the IARVs and other aspects of the gtr in Phase 2. The United States will be conducting fleet testing with the WorldSID dummies to ensure benefits are maintained. It will also examine possible incremental improvements, such as the effect of lowering injury threshold values and adding more injury criteria to Phase 2. These efforts could result in future recommendations to adjust the injury risk values and other aspects of this gtr.

## **6. Head injury**

75. As noted earlier, a very high proportion of fatalities and AIS3+ injuries in pole side impacts and other side impacts are caused by head injuries, predominantly brain injuries. The informal working group determined that the head protection performance should be based on the Head Injury Criterion (HIC) 36, given the ability of the HIC to estimate the risk of serious to fatal head injury in motor vehicle crashes.

76. The informal working group agreed that the HIC36 must not exceed 1,000, which is equivalent to approximately a 50 per cent risk of AIS3+ head injury for a 45-year-old male.

77. The informal working group also considered the Brain Injury Criterion (BRIC) currently being developed by the United States of America. While kinematic head injury criteria, expressed as a function of measured translational head accelerations (such as the HIC), have served well to mitigate head injury, there is still a significant frequency of traumatic brain injury (TBI) in crash-involved automobile occupants. Further research into the physical and biomechanical processes within the traumatically injured brain has identified rotational head kinematics as a potential contributing factor to TBI. A rotational brain injury criterion (BRIC) is under development that utilizes dummy head kinematic information to determine the likelihood of brain injury due to rotation. Additional research, scheduled to be completed in 2013, will determine the methods for calculation and injury risk functions for the BRIC.

78. The informal working group decided that progress on the BRIC and possible incorporation in the gtr should be considered as part of the second phase. Part II includes a place mark for a future BRIC requirement.

## 7. Shoulder performance

79. The AIS 2005 definitions include very few AIS3 upper extremity injuries. In contrast to head and thorax injuries, which occur up to the AIS6 level, upper extremity injuries do not exceed the AIS2 level unless involving an open fracture; a crush or traumatic amputation at, or below the shoulder level; or injuries resulting in significant blood loss (> 20 per cent by volume).

80. ISO WG6 has developed AIS2+ shoulder injury risk curves for the WorldSID 50<sup>th</sup> male as a function of the maximum shoulder rib deflection and the maximum shoulder force. It is important to note that only AIS1 and AIS2 shoulder injuries were observed to occur in the post mortem human subject (PMHS) tests used by ISO WG6 to construct the WorldSID 50<sup>th</sup> male injury risk curves. AIS3 shoulder injury risk curves were therefore not able to be determined.

81. In a severe pole side impact crash, some loading of the occupant is inevitable. To minimize occupant fatality and serious injury (AIS3+) risk in pole side impact crashes it is important to provide vehicle manufacturers with sufficient flexibility to maximize the protection of the body regions for which serious injuries most frequently occur in the field. To achieve the best possible occupant protection it may be necessary to direct impact load towards body regions with the greatest capacity to withstand the impact (for example the shoulder), in order to minimize the loading of more sensitive body regions such as the thorax.

82. A shoulder performance criterion limit based on AIS2 shoulder injury risk may prevent vehicle manufacturers from achieving the best possible thorax protection. The informal working group therefore decided that the AIS2 injury risk curves developed by ISO WG6 should not be used to establish a shoulder performance/injury criterion threshold limit for the gtr.

83. However, the informal working group decided it was important to prevent excessive (i.e. non-biofidelic) loading of the WorldSID 50<sup>th</sup> male shoulder.

84. The shoulder performance criterion limit has been based on the research presented in PSI-07-13, WS-06-05e, and PSI-07-05. The response of the WorldSID 50<sup>th</sup> male shoulder was analysed for a variety of simulation and test conditions. The force-deflection curve of the shoulder rib was shown to have a similar shape in each analysed data set. No linear dependency between force and deflection was able to be established for the shoulder rib. The shoulder force-deflection curve has a degressive slope and builds up a 2.0-2.5 kN force plateau between 40-70 mm deflection.

85. Provided the shoulder rib does not experience severe loading leading to deformations greater than its design specifications, the WorldSID 50<sup>th</sup> male shoulder will provide a biomechanically valid load path.

86. The informal working group agreed the peak lateral shoulder force shall not exceed 3.0 kN (20 per cent higher than the biofidelic shoulder load observed in research tests) to prevent excessive non-biofidelic shoulder loadings from being used to offload the thorax in a non-biofidelic way.

87. The deflection measurement system proposed for the shoulder of the WorldSID 50<sup>th</sup> male has a maximum measurement capability of 65-70 mm. When shoulder deflections occur at or beyond this level the durability limits of the measurement device can be exceeded and breakages are common. As the shoulder criterion is being included for the purpose of detecting excessive (non-biofidelic) loading, the group considered alternative means of measuring shoulder deflection. A revised dummy design was proposed with a shoulder 'stop' in place of the linear measurement device. This stop would be specified in such a way that it has no impact on biofidelic interactions with the shoulder, but that contact between the shoulder rib and the stop would produce an easily measureable peak in

the event of non-biofidelic deflection. The group agreed that a design change to the dummy was not appropriate for the first phase of the gtr, but that this issue could be considered further as part of the second phase.

## **8. Thorax performance**

88. A high proportion of fatalities and AIS3+ injuries in pole side impacts and other side impacts are also caused by thorax injuries.

89. The informal working group agreed that the maximum thorax rib deflection must not exceed 55 mm, which is equivalent to approximately 50 per cent risk of AIS3+ thoracic skeleton injury for a 45-year-old male.

90. There was initially some concern that using a thorax injury risk curve for a 45-year-old to set this limit may not guarantee appropriate protection for older occupants, especially given many countries now have ageing populations. However, given the median age for victims of pole side impacts is much lower than 45 (and much lower than that of victims of other side impacts), it was agreed that the thorax protection needs of older occupants in particular may be more appropriately addressed by updating mobile deformable barrier side impact test requirements. For example, a thorax injury risk curve for a 67 year old (the average age of the PMHS used in tests from which injury risk curves are derived) may appropriately be used to set the thorax rib deflection limit if mobile deformable barrier side impact regulations are reviewed.

91. The informal working group also considered including a peak thorax viscous criterion, but decided against doing so in the first phase of the gtr, as ISO WG6 has not been able to construct an AIS 3+ thoracic viscous criterion injury risk curve with an acceptable quality index.

92. However, it is important to note that many Contracting Parties have been using a viscous criterion in national/regional mobile deformable barrier side impact regulations. In particular, some Contracting Parties to the 1958 Agreement noted that such a criterion has successfully been used with EuroSID 1 and ES-2 for more than a decade in Regulation No. 95. Some Contracting Parties would therefore like the injury risk curves for this criterion to be investigated further as they may wish to use or continue using a viscous criterion in future regulatory side impact applications of the WorldSID 50<sup>th</sup> male. This load rate sensitive biomechanical criterion is believed to encourage close attention to the door design, including control of the door intrusion speeds. Well controlled door intrusion speed responses are known to be particularly important for the protection of occupants in side impact crashes. For this reason, door intrusion speed simulation was incorporated in the sled test methods developed for the new UN Regulation on child restraint systems. Progress in developing a peak thorax viscous criterion should therefore be considered further in the second phase of the gtr, as well as for other future regulatory side impact standards.

93. The gtr includes reference to Addendum 2 of the Mutual Resolution. This Addendum will include the drawings and user manual for the WorldSID 50<sup>th</sup> percentile adult male Build Level F. This includes 2-dimensional rib deflection measurement despite the thorax injury criterion for the gtr at this stage including a 1-dimensional deflection limit. This is because the thorax injury risk curves developed to date are 1-dimensional injury risk curves, suitable for side impact tests in which the dummy thorax is loaded in a predominantly lateral direction (as has been found in the majority of 75 degree oblique pole side impact tests). The use of a 2-dimensional measurement system allows for 2-dimensional thorax (and abdominal) deflection based injury criteria to be used in the future without requiring a change to the dummy rib deflection measurement system.

## 9. Abdominal performance

94. A smaller, yet still significant, proportion of fatalities and AIS3+ injuries in pole side impacts and other side impacts are caused by abdominal/pelvic injuries.

95. In terms of AIS3+ abdominal injury risk, a 65 mm maximum WorldSID 50<sup>th</sup> male abdominal rib deflection is equivalent to the 2.5 kN total (sum of the front, middle and rear) internal abdominal force limit used as the abdominal performance criterion threshold limit for the ES-2 in Regulation No. 95 and the ES-2re in FMVSS 214.

96. ISO WG6 determined the 50 per cent AIS2+ abdominal soft tissue injury risk threshold value as a function of the maximum abdominal rib deflection to be 79.8 mm for a 45-year-old male. However, the WorldSID 50<sup>th</sup> male ribs cannot physically deflect this much. The abdominal ribs of the WorldSID 50<sup>th</sup> male dummy partially overlap the floating thorax ribs of a mid-size adult male. To protect both the thoracic rib cage and the abdominal soft tissue, the informal working group agreed that the maximum abdominal rib deflection shall not exceed 65 mm.

97. The informal working group also agreed that the lower spine acceleration must not exceed 75 g (1 g = the acceleration due to gravity = 9.81 m/s<sup>2</sup>), except for intervals whose cumulative duration is not more than 3ms.

98. While ISO WG6 recommended abdominal rib deflection as the best predictor of abdominal soft tissue injury risk, the lower spine acceleration criterion has also been included by the informal working group because it may in some specific circumstances detect severe lower thorax and abdominal loadings that a 1-dimensional abdominal rib deflection criterion may not. This concern may be addressed in the future by the introduction of 2-dimensional rib deflection criterion, but in the meantime this acceleration based criterion is expected to detect unusual loadings, such as excessive airbag loadings from behind the dummy, without requiring vehicle design changes for normal load conditions.

99. This concern arose from analysis of a pole side impact test conducted by Australia and Transport Canada using multi-point sensing (PSI-06-13). It was generally noted that the differences between the theoretical 1-dimensional deflection measurement and the peak middle LED y-axis displacement (that is, the WorldSID 50<sup>th</sup> male half thorax compression) were in most cases small, especially for oblique pole tests. However, it was noted that in this particular test, the loading of the thorax/abdomen from behind by the seat mounted side airbag had caused substantial forward rotation of the ribs. As a result, the theoretical 1-dimensional deflection measurement in this test was considerably less than the peak y-axis deflection measured using multi-point sensing. However, the 3 ms lower spine acceleration was well over 75 g (120 + g) and this was the only test to produce a 3 ms lower spine acceleration in excess of 75 g.

100. Other pole side impact tests jointly conducted by Australia and Transport Canada showed that at least a 60 mm maximum abdominal rib deflection would typically be required under normal vehicle-to-pole side impact dummy load conditions to generate a 3ms lower spine acceleration in excess of 75 g.

## 10. Pelvic performance - pubic symphysis

101. To protect the pelvis, the informal working group agreed that the maximum pubic symphysis force must not exceed 3.36 kN, which is equivalent to approximately a 50 per cent risk of AIS3+ pelvic injury for a 45-year-old male.

**11. Pelvic performance - sacro-iliac**

102. Current WorldSID 50<sup>th</sup> male injury risk functions for the entire pelvis are based on the pubic symphysis load and pelvic acceleration. While the pubic symphysis load is measured at the anterior portion of the pelvis, there is field evidence of posterior pelvic injury that may not be detected by the pubic symphysis load cell. The WorldSID 50<sup>th</sup> male pelvis has a posterior sacro-iliac joint load cell for which no injury risk function exists. Research is underway to determine how the sacro-iliac and pubic symphysis loads interrelate, to establish whether injury criteria can be independently defined for the pubic symphysis and sacro-iliac. This issue can be considered further in the second phase.

**12. Seat adjustment and installation requirements**

103. ISO established ISO/TC22/SC10/WG1 (ISO WG1) to develop car collision test procedures. This working group developed a draft seating procedure (ISO/DIS 17949:2012) for positioning the WorldSID 50<sup>th</sup> male in front outboard seating positions. This draft ISO standard was developed to provide a repeatable seating and positioning procedure able to be applied across the world vehicle fleet. In the interests of harmonization of international standards, the informal working group agreed, wherever possible, to align the seat adjustment and installation requirements for the WorldSID 50<sup>th</sup> male dummy in Annex 2 to the gtr with suitable procedures developed and/or recommended by ISO WG1.

104. The lumbar support, other seat support, head restraint, safety-belt anchorage, steering wheel and pedal adjustment requirements have been aligned with the ISO/DIS 17949 draft requirements developed by ISO WG1.

105. The "procedure for establishing the test position of an adjustable seat cushion" is based on a similar procedure developed by ISO Working Group 1 for the ISO/DIS 17949:2012 draft standard.

106. The "procedure for manikin H-point and actual torso angle determination" has been adapted from the procedures for H-point and actual torso angle determination used in gtr No. 7, and Regulations No. 94 and No. 95. The seat back angle adjustment requirements have been aligned with the requirements of the ISO/DIS 17949:2012 draft standard.

107. The H-point manikin (3-D H Machine) specified for the determination of the manikin H-point and actual torso angle is the device specified and used in SAE J826 1995. This machine corresponds to the 3-D H Machine used in gtr No. 7 and to that described in ISO 6549: 1999.

108. Some preliminary consideration was given to incorporating the specifications, including more detailed tolerances, of the 3-D H machine in an Addendum of the Mutual Resolution (on test tools). However, it was decided that the specification of improved 3-D H Machine tolerances was not within the terms of reference of the informal working group, and would be relevant to other gtrs, as well as a number of Regulations.

109. The dummy installation procedure in the gtr has been aligned with the procedure developed by ISO WG1 for the ISO/DIS 17949:2012 draft standard.

110. The informal working group acknowledges the role of the ISO in developing ISO/DIS 17949 and thanks the ISO for its cooperation in making text from this draft standard available for use in developing Annex 2 of the gtr. Copyright in the text from ISO/DIS 17949 remains with ISO and an original copy of the standard can be obtained by ISO members or from ISO directly at [www.iso.org](http://www.iso.org).



### 13. Impact alignment tolerance

111. The informal working group considered research undertaken by Australia (PSI-05-10) which showed that changing the pole impact alignment by 100 mm can make as much difference to the WorldSID 50<sup>th</sup> male peak rib deflection responses as changing the angle of impact by 15 degrees.

112. The FMVSS 214 and EuroNCAP pole side impact protocols include a  $\pm 38$  mm impact alignment tolerance (making a 76 mm wide allowable impact zone). However, analysis of actual impact alignments in Australian and Canadian pole side impact research tests, Australian NCAP pole tests and US NCAP pole tests indicated that it is feasible to consistently produce an actual impact alignment within 15 mm of the target impact alignment.

113. The informal working group accordingly agreed to a  $\pm 25$  mm impact alignment tolerance. This will ensure type approvals are issued based on tests of comparable stringency.

### 14. Test mass tolerance

114. The gtr regulatory text includes a requirement for the vehicle test mass, including the mass of the necessary anthropomorphic test device and any ballast mass, to be within  $+0/-10$  kg of the laden mass defined in Annex 1. This requirement defines a test mass tolerance for Contracting Parties to use in compliance testing of vehicle models/variants supplied to their market. The informal working group recognised that it would be necessary, where the gtr is implemented in type approval systems, to ensure that tests can be applied to a range of variants. Contracting Parties may therefore relax this test mass requirement in regional or domestic legislation by allowing a test conducted on a worst case and/or sufficiently representative variant to be used to demonstrate compliance for other variants.

115. For example, Regulation No. 95 incorporating all valid text up to the 03 series of amendments (E/ECE/324-E/ECE/TRANS/505/Rev.1/Add.94/Rev.1), includes a section on the modification of the vehicle type which states:

*"Any modification affecting the structure, the number and type of seats, the interior trim or fittings, or the position of the vehicle controls or of mechanical parts which might affect the energy-absorption capacity of the side of the vehicle, shall be brought to the notice of the Type Approval Authority granting approval.*

*The department may then either:*

- (a) Consider that the modifications made are unlikely to have an appreciable adverse effect and that in any case the vehicle still complies with the requirements; or*
- (b) Require a further test report from the Technical Service responsible for conducting the tests.*

*Any modification of the vehicle affecting the general form of the structure of the vehicle or any variation in the reference mass greater than 8 per cent which in the judgement of the authority would have a marked influence on the results of the test shall require a repetition of the test...."*

116. The informal working group considered that a similar approach allowing for worst case variant selection and for full scale vehicle tests results to be extended to a range of variants would need to be allowed where the gtr is implemented in type approval systems. This allows vehicle manufacturers to obtain approval for a range of model variants for which the test conducted is representative, and limits the cost of testing without reducing the levels of occupant protection required.

**15. Parking brake / transmission**

117. Existing procedures for pole side impact tests include setting requirements for both the test vehicle parking brake and transmission. These requirements were discussed within the informal working group. The group was of the view that the main function of both prescriptive requirements was to limit movement of the vehicle prior to impact with the pole, and therefore maximise accuracy of the impact location. As the gtr includes a performance requirement for impact alignment accuracy it was agreed that the requirements for parking brake and transmission were unnecessary. However, in order to maintain a consistent test configuration and minimise testing problems the group agreed to include a requirement that the parking brake be engaged. Requirements on transmission engagement were not included as these appeared inconsistent within the requirement and incompatible with some modern vehicle drivetrains. The group agreed that transmission setting would have no effect on the result of a test.

**16. Maximum vehicle acceleration**

118. The gtr includes a  $1.5 \text{ m/s}^2$  limit on acceleration of the test vehicle. This limit is prescribed to minimise the possibility of movement of the dummy within the vehicle during the acceleration phase of the test prior to impact with pole. The gtr seating procedure requirements/tolerances are very precise, and accurate positioning of the dummy is very important to the repeatability/reproducibility of test results. Rapid acceleration of the vehicle towards the pole has the potential to adversely influence the test repeatability/reproducibility, as the dummy may move in the time between final positioning and the impact into the pole. This limit will have the added benefit of minimising the possibility for movement of the vehicle on a carrier sled if that test configuration is used. It is anticipated that the majority of test laboratories will perform pole side impact tests with the test vehicle on a carrier sled, as this is regarded as the best method to achieve accurate vehicle alignment. This procedure requires that there is very low friction between the vehicle tyres and the sled surface to ensure that the impulse of the sled does not affect the test result. This is typically achieved by fixing friction reducing pads to both the vehicle tyre and sled. While this low friction installation is desirable for the result of the test, it is necessary to limit the vehicle acceleration to prevent movement of the vehicle on the sled prior to impact with the pole. The gtr does not require this test configuration to be used and other test configurations are likely to be able to meet the test performance requirements of the regulation.

**17. Indicative pitch and roll angle measurement**

119. Fixed linear references are used in the gtr to control the attitude of the test vehicle. These linear references are used to measure the pitch angles on each side of the vehicle and the roll angles at the front and rear of the vehicle. The pitch and roll angles of the vehicle in the test attitude shall be between the corresponding unladen attitude angles and the laden attitude angles, inclusive. Pitch and roll angles are also covered in Annex 6. Exaggerated figures, showing how the pitch angle ( $\theta_p$ ) and roll angles ( $\theta_r$ ) are measured relative to a level surface or horizontal reference plane are included for illustrative purposes below.

Figure 1  
Exaggerated illustration of front left door sill pitch angle.

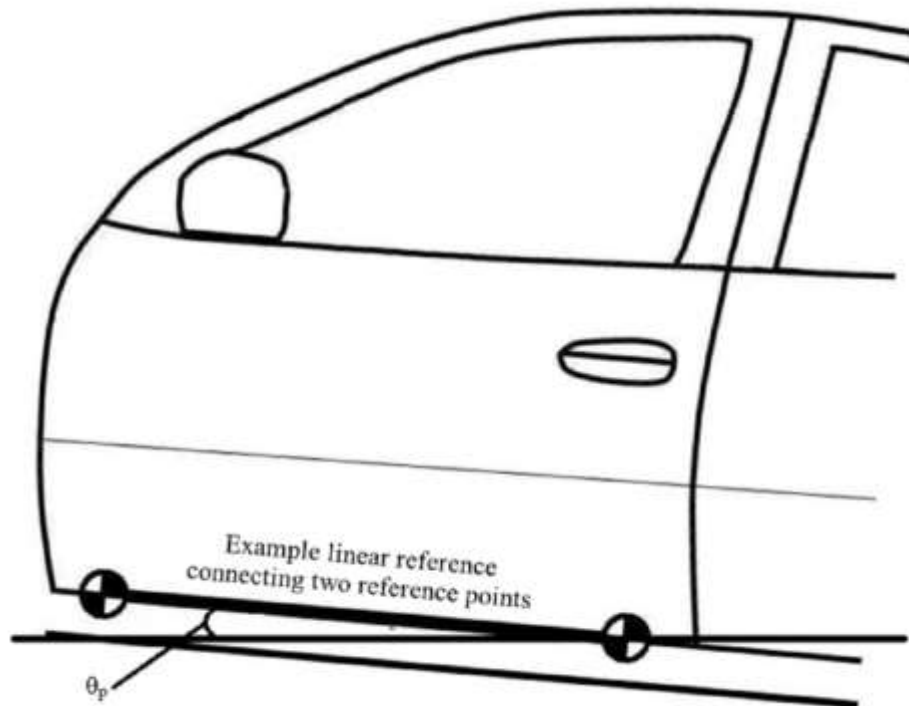
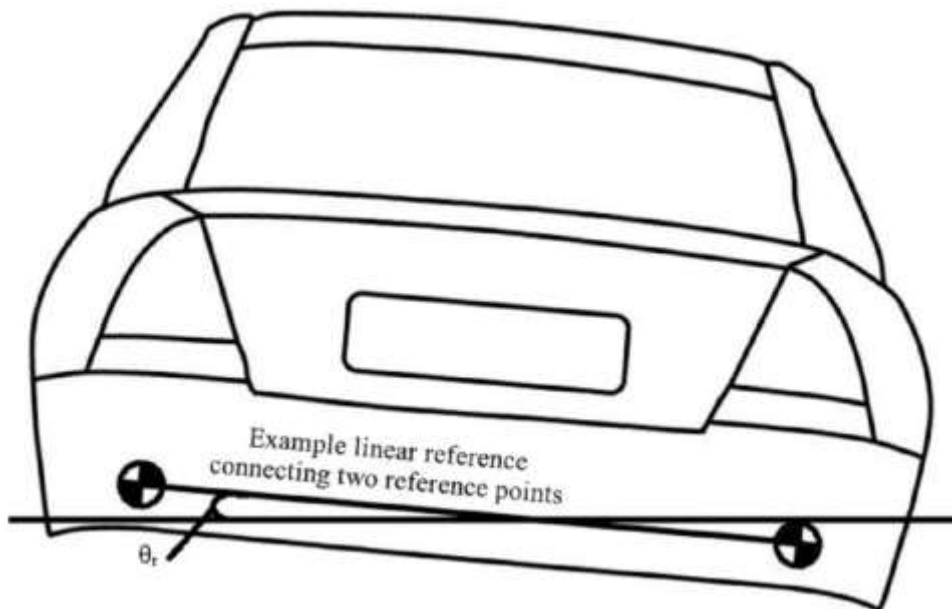

Figure 2  
Exaggerated illustration of rear roll angle.



**18. Electrical safety**

120. The informal working group noted that AC.3 had agreed to develop a proposal for a gtr on electric vehicle safety and that an informal working group had been established to develop the gtr. It was decided to leave electrical vehicle safety requirements out of the regulatory text for the pole side impact gtr for now, pending a possible future proposal. Progress on this matter can be considered as part of the second phase.

**19. Unlocking of door**

121. There was some discussion within the informal working group whether there should be a requirement in the gtr for the doors to be unlocked after impact. It was agreed that this matter could be considered further if and when a workable proposal was able to be developed in conjunction with a safety need case. This matter can be considered further as part of the second phase.

**F. Regulatory impact and economic effectiveness**

122. Assessment of the effectiveness and benefits and costs of implementing the gtr are likely to be highly particular to individual Contracting Parties, depending on factors such as the regulatory or NCAP pole side impact test requirements already in application, vehicle fleet makeup, current and projected levels of ESC and side airbag fitment, the type of airbags fitted and fatality and injury numbers in both pole and other side impacts, including particularly the type and severity of injuries. The following sections on effectiveness, benefits and costs of the gtr are intended to provide guidance to Contracting Parties on the types of factors to be considered, providing some examples drawn from national data and analyses that have already been undertaken. However, in considering the case for implementation of the gtr, detailed benefit-cost analysis will need to be undertaken by individual Contracting Parties or regional groupings. As a general rule, however, high costs are likely to be matched by high benefits (for example in situations where there is low fitment of side airbags of any kind).

**20. Effectiveness**

123. As previously noted, the passive safety countermeasures expected to be used in vehicles to meet the requirements of the gtr (most likely side curtain airbags and thorax airbags, but in some cases also including structural countermeasures) are likely to reduce injury risk in pole side impact crashes as well as other side impact crashes, including car to car crashes. The effectiveness of the gtr will depend on the extent to which countermeasures are already required or otherwise present in countries. This is influenced by the regulatory requirements and voluntary standards applying.

124. As part of its consultancy on the safety need, effectiveness and benefits and costs of the gtr, MUARC conducted an analysis of studies on the effectiveness of side airbags. The studies were published in the period 2003-2011. On the basis of its analysis, MUARC decided to "use a (baseline) 32 per cent reduction in fatalities due to the presence of a curtain plus thorax side airbag system ... (and to) adopt a value of 34 per cent as our basis of reduction in injuries"<sup>17</sup> This baseline reduction in fatalities and injuries is in comparison to a situation in which there is no side airbag protection.

---

<sup>17</sup> Fitzharris et al, p 22

125. MUARC then considered the improvements in airbag effectiveness that are likely to be required by the gtr, in particular considering the situation in Australia where ANCAP conducts perpendicular pole side impact tests. MUARC noted that the nature of the gtr test itself would "require key changes to the design of current airbag and airbag sensor systems. Collectively, these changes would be expected to improve the effectiveness of side airbag systems by providing improved coverage for a broader range of occupants and would provide improved protection across a larger range of impact angles experienced in real-world crashes"<sup>18</sup>

126. MUARC noted that many seat mounted thorax airbags would need to be made to extend slightly more forward of the vehicle seat. This is because compared to the perpendicular test, under the oblique test requirements of the gtr, the pole impacts the vehicle in a more forward location relative to the vehicle seat and dummy thorax. The dummy would also move slightly forward relative to the seat (i.e. towards the pole) in an oblique pole test.

127. MUARC also noted that many thorax airbags would also be made larger to provide greater coverage of other body regions such as the shoulder and pelvis. This may help to distribute impact loadings more evenly and avoid concentrated loading of the sensitive thorax region. These larger thorax airbags are likely to be used to absorb more of the dummy's kinetic energy (to meet the thorax injury criteria limit in the gtr), which will reduce the amount of energy required to be absorbed by deflection of the dummy thorax (or occupant's thorax in field crashes).

128. These changes would be expected to improve the effectiveness of thorax airbags, including for a range of occupant sizes and across a range of side impact angles. The informal working group saw an example of likely airbag design changes when a vehicle from the North American market compliant with FMVSS 214 was compared to the same vehicle sold in the Australian market, notwithstanding that the latter vehicle had received a 5 star ANCAP safety rating (PSI-07-03).

129. MUARC noted that a further source of increased protection was that the oblique test performance requirements of the gtr would likely demand improved impact detection systems to be developed and installed. This would have important implications for the 'tuning' of the airbag deployment in the event of a crash. More reliable sensors, that is, an improved ability to detect a side impact crash which then leads to optimised side airbag deployment would be expected to have benefits across the range of real-world crashes.

130. MUARC also noted that the use of the WorldSID 50<sup>th</sup> male would be expected to more accurately capture the risk of injuries to occupants due to its higher biofidelity and more accurate anthropometry than crash test dummies currently being used for pole side impacts. A high correlation between the measured responses of the test dummy and the occupant in the field would be critical to ensure the validity of the crash test itself. The anthropometry of the WorldSID 50<sup>th</sup> male would offer improved opportunities to align the seating position and airbag design more appropriately, leading to improved head injury protection in particular.

131. Taking these factors together, MUARC estimated a 30 per cent increase in airbag effectiveness required by the gtr, compared to current curtain plus thorax side airbag systems, providing a 41.6 per cent reduction in fatalities and a 44.2 per cent reduction in serious injuries.

---

<sup>18</sup> Fitzharris et al, p 124

132. These figures are consistent with analysis undertaken by NHTSA which estimated that a total 47 per cent reduction in fatalities was achievable.<sup>19</sup>

133. The effectiveness of the gtr is also likely to be increased by the fact that the injury curves used in setting injury criteria were adjusted for 45-year-old males providing an additional level of protection for the younger demographic associated with pole side impacts in particular.

## **21. Benefits**

134. Calculation of benefits from the gtr in a particular country will need to take account of the likely effectiveness of the gtr in that country. For instance, effectiveness will be significantly greater in a country in which neither regulated nor voluntary pole side impact standards apply than in the United States of America, where pole side impact standards apply in regulation and voluntary standards; or in European countries, the Republic of Korea and Australia where voluntary standards apply.

135. Another key factor in determining the level of benefits will also be the number of fatalities and injuries being addressed – that is, the target population. As seen in Table 1, even in percentage terms or rates per 100,000 this can vary significantly between countries. The target population in all countries is likely to be reduced over time by factors such as current and projected fitment rates of side airbag protection (of any kind) and current and projected fitment rates of ESC and other crash avoidance technologies. Contracting Parties will need to consider such factors when considering adoption of the gtr into domestic legislation. On the other hand, Contracting Parties may wish to take account of the potential for the gtr to reduce rollover fatalities and injuries, noting that ESC is likely to be particularly effective in reducing rollover crashes and that it has not been possible to assess the effectiveness of the gtr in rollover crashes. Other factors will also be relevant in assessing benefits, including the current and future shape of the vehicle fleet in Contracting Parties.

136. Having determined the scale of the problem being addressed and the level of effectiveness, Contracting Parties will be able to determine reductions in fatalities and injuries and the monetary benefits flowing from this. In Australia, the most recent value (2010) of a statistical life is A\$ 4.9 Million, while for serious injury it is A\$ 804,000 and for minor injury A\$ 30,000.

137. These values will vary from country to country. However, the informal working group particularly noted the high level of brain injury in side impacts, with serious brain injuries prevalent in pole side impacts. Based on insurance claims data, in Australia it has been estimated that the societal and lifetime care cost of severe brain injury (taken to be AIS4+) is A\$ 4.8 Million and moderate brain injury (taken to be AIS3) is A\$ 3.7 Million (2009). It has also been estimated that paraplegia costs A\$ 5 Million per case. Again while values will vary from country to country, any assessment of benefits of the gtr should consider the types of injuries being avoided and the high level of benefits associated with avoiding brain and spinal cord injuries, as illustrated by the Australian data.

---

<sup>19</sup> Fitzharris et al, p 123

## 22. Costs

138. Australia attempted to obtain detailed and up-to-date cost estimates for the gtr on pole side impact from industry participants of the informal working group. However, OICA advised that their members would not be able to provide up-to-date cost estimates due to concerns about the sharing of internal costs amongst companies competing in the same marketplace and concerns that any sharing of internal cost data could be viewed as a breach of anti-trust legislation in some countries. The informal working group therefore decided to use previous cost analysis undertaken by NHTSA.

139. The informal working group also considered using a study undertaken by the European Enhanced Vehicle-safety Committee (EEVC) that investigated the societal benefit to be gained from introduction of a pole side impact test in regulation. The report was finalised in 2010 and the results were presented during the first meeting of the informal working group (PSI-01-17). The estimated costs for upgrading cars of different categories to fulfil pole side impact requirements ranged from 98 Euro to 506 Euro depending of the car category and the level of safety that was already provided by the car. Contracting Parties represented in the informal working group agreed that the estimated costs for upgrading a vehicle to meet the pole side impact requirements were too high and therefore did not consider this approach further for cost analysis for the gtr.

140. The FMVSS 214 Final Regulatory Impact Analysis to add an oblique pole side impact test (published in 2007), included estimated side impact restraint system component costs (in 2004 United States dollars – US\$) based on vehicle teardown studies. All costs were reported as consumer costs which were obtained by multiplying the variable manufacturing costs of restraint system components obtained in the teardown studies by a factor of 1.51.

141. These costs can be inflated to 2012 US dollar costs using an inflation scaling factor calculated from US consumer price index (all urban consumers) data. The annualised US consumer price index was 188.9 in 2004 and 229.6 for 2012. The inflation scaling factor to convert 2004 US dollar costs to 2012 US dollar costs is therefore 1.22 (i.e. 229.6/188.9).

142. NHTSA estimated the typical cost of a frontal airbag capable control module (in 2004 dollar terms) to be US\$ 177.31. Based on this estimate, a typical frontal airbag capable control module can therefore be estimated to cost US\$ 216 in 2012 dollar terms.

143. NHTSA then estimated side airbag system costs (i.e. side airbag, sensor and side airbag control module capability costs) for a variety of side airbag systems. The key side airbag system types and 2004 US dollar costs estimated by NHTSA are summarized in Table 5 below. The 2012 US dollar costs shown have been obtained using the inflation scaling factor summarized above. NHTSA categorized airbags as either "current" (i.e. representative of circa 2004 US market vehicle side airbags prior to the implementation of the FMVSS 214 oblique pole test requirements) or "wider". It was assumed "wider" side airbags would be used by vehicle manufacturers to meet the performance requirements of an oblique pole test. These "current" and "wider" side airbags are described as "narrow" and "wide" side airbags below.

Table 5  
**Estimated cost of installing side airbag/restraint systems for vehicles already equipped with a frontal airbag system**

<i>System Type</i>	<i>Side Restraint System Costs</i>	
	<i>US\$ (2004)</i>	<i>US\$ (2012)</i>
Narrow combination airbag and a peripheral sensor on each side	116	141
Narrow curtain airbag, narrow thorax airbag and a peripheral sensor on each side	235	287
Wide combination airbag and a peripheral sensor on each side	126	154
Wide curtain airbag, wide thorax airbag and a peripheral sensor on each side	243	296
Wide curtain airbag, wide thorax airbag and 2 peripheral sensors on each side	280	342

144. As it was assumed wide side airbags would be used by vehicle manufacturers to meet the performance requirements of an oblique pole test, the incremental cost per vehicle relative to vehicles that would otherwise have been fitted with narrow side airbags or frontal airbags only (no side airbags) can be obtained from Table 5. Some estimated incremental costs are shown in Table 6 below.

Table 6  
**Incremental cost matrix for vehicles already fitted with frontal airbags, but requiring wide side airbags to meet oblique pole side impact performance requirements**

	<i>Incremental Costs US\$ (2012)</i>	
	<i>Wide curtain airbag, wide thorax airbag and a peripheral sensor on each side</i>	<i>Wide curtain airbag, wide thorax airbag and 2 peripheral sensors on each side</i>
No side airbags	296	342
Narrow combination airbag and a peripheral sensor on each side	155	201
Narrow curtain airbag, narrow thorax airbag and a peripheral sensor on each side	9	55

145. It is important to note that the 2004 US dollar costs originally presented by NHTSA in the FMVSS 214 regulatory impact analysis were obtained by inflating 1999 US dollar costs to 2004 US dollar costs. However it is widely accepted that the real cost of new and emerging technology typically decreases as demand and production increase in scale over time. This means side restraint system component costs obtained by inflating 1999 US dollar costs to 2012 US dollar costs could be expected to represent maximum component cost estimates.



146. The incremental component cost per vehicle associated with implementation of the gtr on pole side impact will depend on the side impact occupant protection countermeasures being fitted under business as usual in a particular country or region at the time of implementation in domestic legislation. These calculations are a matter for each Contracting Party to determine.

147. For countries and regions where voluntary pole side impact programmes (e.g. NCAP programmes) apply and side airbag fitment rates are high, the incremental side impact restraint system costs associated with the gtr on pole side impact would be expected, on the basis of the costs estimated by NHTSA, to approach a level somewhere between the US\$ 9 and US\$ 55 per vehicle cost scenario shown in Table 6.

148. MUARC was able to obtain cost information from an industry expert who advised that the cost of the gtr on pole side impact for a current Australian sold vehicle would be about A\$ 20 for design considerations and probably no more than A\$ 50 for additional parts and enhancements, like sensors, more forward reaching airbags and slightly larger inflators (per vehicle). The "no more than A\$ 50 for additional parts and enhancements" advice provided by the industry expert is consistent with the US\$ 55 cost estimate shown in Table 6.<sup>20</sup>

149. It is important to note that the gtr sets performance based requirements which will not necessarily require all vehicles to be fitted with side airbag systems. Vehicle manufacturers may use any occupant protection countermeasures they design/develop, provided the vehicle satisfies the performance based requirements of the gtr. However, side airbag restraint systems are the primary countermeasure known to have been used to absorb dummy impact energy and achieve performance improvements observed in pole side impact crash tests of vehicles manufactured over the last 10-15 years. Side airbag systems are currently being used in vehicles which meet the FMVSS 214 oblique pole side impact requirements as well as vehicles which achieve 5 star NCAP ratings. It is likely that side airbags will be widely used to meet the performance based requirements of the gtr, unless manufacturers develop other countermeasures which are at least as cost effective to produce and/or provide comparable or better test performance; and are also accepted by consumers.

150. NHTSA did not estimate vehicle re-design and development costs in the FMVSS 214 regulatory impact analysis. Instead, NHTSA noted that these costs would be small, if allowed to occur at the time of the normal model re-design. Consequently, the FMVSS 214 oblique pole side impact test requirements currently include phase-in allowances applicable to various vehicle categories/types manufactured between 1 September 2010 and 31 August 2015.

151. Pole side impact crash tests of 2010 model or later North American market vehicles conducted by NHTSA (PSI-06-12) and Australia and Transport Canada (PSI-05-05; PSI-07-03) suggest a majority of vehicles assumed or known to meet the ES-2re pole side impact performance requirements of FMVSS 214, would also meet the performance requirements of the gtr. Although compliance cannot automatically be guaranteed for every model, this suggests similar countermeasures will generally need to be developed (for a majority, but not all vehicles) to comply with the gtr to those that are currently being used to comply with the FMVSS 214 oblique pole side impact test requirements.

---

<sup>20</sup> Fitzharris et al, p 136-139

## **G. Summary of issues to be considered in the second phase**

152. In the above text, a number of issues have been identified for consideration in the second phase. For ease of reference, these can be briefly summarised as:

- (a) Incorporation of the WorldSID 5<sup>th</sup> percentile adult female in the gtr;
- (b) Review of test speed exemption for narrow vehicles;
- (c) Consideration of a shoulder stop or inclusion of a shoulder rib deflection limit in the performance criteria of the gtr;
- (d) Progress on the Brain Injury Criterion (BRIC) and possible incorporation in the gtr;
- (e) Progress in developing a peak thorax viscous criterion;
- (f) Progress in developing a sacro-iliac injury criterion;
- (g) Electrical safety requirements; and
- (h) A possible requirement in the gtr for the doors to be unlocked after impact.

## **H. Leadtime**

153. It should be noted that the requirements of the gtr are generally more stringent than existing legislation or even voluntary standards at the time of adoption of the gtr. In addition, many countries do not yet have pole side impact requirements under either regulation or voluntary standards.

154. It is therefore recommended that Contracting Parties implementing this gtr allow adequate lead time before full mandatory application, considering the necessary vehicle development time and product lifecycle.

155. It is also recognised that Contracting Parties may vote to adopt the gtr into the Global Registry, but not be obliged to submit the gtr to the process used for adoption into its national regional law until Addendum 2 of the Mutual Resolution No. 1 is adopted.

## II. Text of the Regulation

### 1. Purpose

The purpose of this regulation is to reduce the risk of serious and fatal injury of vehicle occupants in side impact crashes by limiting the forces, accelerations and deflections measured by anthropomorphic test devices in pole side impact crash tests and by other means. This may complement other side impact tests.

A Contracting Party may continue to apply any pre-existing domestic pole side impact requirements using a 5<sup>th</sup> percentile adult female side impact dummy.<sup>1</sup>

### 2. Application and scope

This regulation shall apply to all Category 1-1 vehicles; Category 1-2 vehicles with a Gross Vehicle Mass of up to 4,500 kg; and Category 2 vehicles with a Gross Vehicle Mass of up to 4,500 kg.<sup>2</sup>

### 3. Definitions

For the purposes of this Regulation:

- 3.1. "*Back Door*" is a door or door system on the back end of a motor vehicle through which passengers can enter or depart the vehicle or cargo can be loaded or unloaded. It does not include:
- (a) A trunk lid; or
  - (b) A door or window that is composed entirely of glazing material and whose latches and/or hinge systems are attached directly to the glazing material.
- 3.2. "*Door latch system*" consists, at a minimum, of a latch and a striker.
- 3.3. "*Fuel ballast leakage*" means the fall, flow, or run of fuel ballast from the vehicle but does not include wetness resulting from capillary action.
- 3.4. "*Fully latched position*" is the coupling condition of the latch that retains the door in a completely closed position.
- 3.5. "*Hinge*" is a device used to position the door relative to the body structure and control the path of the door swing for passenger ingress and egress.
- 3.6. "*Latch*" is a device employed to maintain the door in a closed position relative to the vehicle body with provisions for deliberate release (or operation).

---

<sup>1</sup> Pre-existing pole side impact requirements are regulations or standards implemented in domestic legislation at the time this Global Technical Regulation is established in the Global Registry.

<sup>2</sup> A Contracting Party may restrict application of the requirements in its domestic legislation if it decides that such restriction is appropriate. More details are available in Part I of this gtr.

- 3.7. "Latched" means any coupling condition of the door latch system, where the latch is in a fully latched position, a secondary latched position, or between a fully latched position and a secondary latched position.
- 3.8. "Passenger compartment" means the space for occupant accommodation, bounded by the roof, floor, side walls, doors, outside glazing and front bulkhead and the plane of the rear compartment bulkhead or the plane of the rear-seat back support.
- 3.9. "Secondary latched position" refers to the coupling condition of the latch that retains the door in a partially closed position.
- 3.10. "Striker" is a device with which the latch engages to maintain the door in the fully latched or secondary latched position.
- 3.11. "Trunk lid" is a movable body panel that provides access from outside the vehicle to a space wholly partitioned from the passenger compartment by a permanently attached partition or fixed or fold-down seat back (in the position of occupant use).

#### **4. Requirements**

- 4.1. A vehicle tested in accordance with Annex 1, using a WorldSID 50<sup>th</sup> percentile adult male dummy<sup>3</sup>, shall meet the requirements of paragraphs 4.2., 4.4., and 4.5.
- 4.2. WorldSID 50<sup>th</sup> percentile adult male performance requirements
  - 4.2.1. The performance criteria measured by a WorldSID 50<sup>th</sup> percentile adult male dummy in the front-row outboard seating position on the impact side of a vehicle tested in accordance with Annex 1, shall meet the requirements of paragraphs 4.2.2. to 4.2.6.
  - 4.2.2. Head Injury Criteria
    - 4.2.2.1 The Head Injury Criterion (HIC) 36 shall not exceed 1,000 when calculated in accordance with paragraph 1. of Annex 7.
    - 4.2.3. Shoulder performance criteria
      - 4.2.3.1. The peak lateral shoulder force shall not exceed 3.0 kN when calculated in accordance with paragraph 3.1. of Annex 7.
      - 4.2.4. Thorax performance criteria
        - 4.2.4.1 The maximum thorax rib deflection shall not exceed 55 mm when calculated in accordance with paragraph 4.1. of Annex 7.
        - 4.2.5. Abdominal performance criteria
          - 4.2.5.1. The maximum abdominal rib deflection shall not exceed 65 mm when calculated in accordance with paragraph 5.1. of Annex 7.
          - 4.2.5.2. The resultant lower spine acceleration shall not exceed 75 g (1 g = the acceleration due to gravity = 9.81 m/s<sup>2</sup>), except for intervals whose cumulative duration is not more than 3ms, when calculated in accordance with paragraph 5.2. of Annex 7.

---

<sup>3</sup> Technical specifications, including detailed drawings and procedures for assembly/disassembly of the WorldSID 50<sup>th</sup> percentile adult male dummy are specified in Addendum 2 of Mutual Resolution No. 1.

- 4.2.6. Pelvis performance criteria
  - 4.2.6.1. The peak pubic symphysis force shall not exceed 3.36 kN when calculated in accordance with paragraph 6.1. of Annex 7.
- 4.3. Reserved.
- 4.4. Door latch and hinge system integrity requirements
  - 4.4.1. Any side door which impacts the pole shall not separate totally from the vehicle.
  - 4.4.2. Any door (including a back door, but excluding a trunk lid), which does not impact the pole and is not wholly partitioned from the passenger compartment by a permanently attached partition or fixed or fold-down seat back (in the position of occupant use), shall meet the following requirements:
    - 4.4.2.1. The door shall remain latched;
    - 4.4.2.2. The latch shall not separate from the striker;
    - 4.4.2.3. The hinge components shall not separate from each other or from their attachment to the vehicle; and
    - 4.4.2.4. Neither the latch nor the hinge systems of the door shall pull out of their anchorages.
- 4.5. Fuel system integrity requirements
  - 4.5.1. In the case of a vehicle propelled by fuel with a boiling point above 0 °C, fuel ballast leakage from the fuel system(s)<sup>4</sup> prepared in accordance with paragraph 4.1. of Annex 1 shall not exceed:
    - 4.5.1.1. A total of 142 grams during the 5 minute period immediately following first vehicle contact with the pole; and
    - 4.5.1.2. A total of 28 grams during each subsequent 1 minute period from 5 minutes up until 30 minutes after first vehicle contact with the pole.
  - 4.5.2. In the case of a vehicle propelled by hydrogen fuel:
    - 4.5.2.1. The vehicle shall meet the post-crash fuel system integrity requirements of paragraph 5.2.2. of the global technical regulation on hydrogen and fuel cell vehicles (ECE/TRANS/180/Add.13); and
    - 4.5.2.2. A Contracting Party may require (in domestic legislation) vehicles with liquefied hydrogen storage systems to meet the optional requirements of paragraph 7. of the global technical regulation on hydrogen and fuel cell vehicles (ECE/TRANS/180/Add.13).

---

<sup>4</sup> To ensure liquid leakage from the fuel system can be easily separated and identified, liquids from other vehicle systems may be replaced by the equivalent ballast mass (as per paragraph 4.3. of Annex 1).

## Annex 1

### Dynamic pole side impact test procedure

#### 1. Purpose

Determination of compliance with the requirements of paragraph 4. of this regulation.

#### 2. Definitions

For the purposes of this annex:

- 2.1. "*Fuel ballast*" means water; or Stoddard Solvent; or any other homogeneous liquid with a specific gravity of  $1.0 + 0/-0.25$  and a dynamic viscosity of  $0.9 \pm 0.05$  mPa·s at 25 °C.
- 2.2. "*Gross vehicle mass*" is defined in Special Resolution 1.
- 2.3. "*Impact reference line*" is the line formed on the impact side of the test vehicle by the intersection of the exterior surface of the vehicle and a vertical plane passing through the centre of gravity of the head of the dummy positioned in accordance with Annex 2, in the front-row outboard designated seating position on the impact side of the vehicle. The vertical plane forms an angle of 75° with the vehicle longitudinal centreline. The angle is measured as indicated in Annex 4, Figure 4-1 (or Figure 4-2) for left (or right) side impact.
- 2.4. "*Impact velocity vector*" means the geometric quantity which describes both the speed and direction of travel of the vehicle at the moment of impact with the pole. The impact velocity vector points in the direction of travel of the vehicle. The origin of the impact velocity vector is the centre of gravity of the vehicle and its magnitude (length) describes the impact speed of the vehicle.
- 2.5. "*Laden attitude*" means the pitch and roll angle of the test vehicle when positioned on a level surface with all tyres fitted and inflated as recommended by the vehicle manufacturer and loaded to the laden mass. The test vehicle is loaded by centrally positioning 136 kg or the rated cargo and luggage mass (whichever is less) in the cargo/luggage carrying area over the longitudinal centreline of the vehicle. The mass of the necessary anthropomorphic test device is placed on the front-row outboard designated seating position on the impact side of the vehicle. The front-row seat on the impact side of the vehicle is positioned in accordance with Annex 2.
- 2.6. "*Laden mass*" means unladen vehicle mass, plus 136 kg or the rated cargo and luggage mass (whichever is less), plus the mass of the necessary anthropomorphic test device.
- 2.7. "*Pitch angle*" is the angle of a fixed linear reference connecting two reference points on the front left or right door sill (as applicable), relative to a level surface or horizontal reference plane. An example of a suitable fixed linear reference for left side door sill pitch angle measurement is illustrated in Figure 6-1 of Annex 6.

- 2.8. "Pole" means a fixed rigid vertically oriented metal structure with a continuous outer cross section diameter of  $254 \text{ mm} \pm 6 \text{ mm}$ , beginning no more than 102 mm above the lowest point of the tyres on the impact side of the vehicle in the laden attitude, and extending at least above the highest point of the roof of the test vehicle.
- 2.9. "Rated cargo and luggage mass" means the cargo and luggage carrying capacity of the vehicle, which is the mass obtained by subtracting the unladen vehicle mass and the rated occupant mass from the gross vehicle mass.
- 2.10. "Rated occupant mass" is the mass obtained by multiplying the total number of designated seating positions in the vehicle by 68 kg.
- 2.11. "Roll angle" is the angle of a fixed linear reference connecting two reference points either side of the vehicle longitudinal centre plane on the front or rear (as applicable) of the vehicle body, relative to a level surface or horizontal reference plane. An example of a suitable fixed linear reference for rear roll angle measurement is illustrated in Figure 6-2 of Annex 6.
- 2.12. "Specific gravity" means the density of a reference liquid expressed as a ratio of the density of water (i.e.  $\rho_{\text{liquid}}/\rho_{\text{water}}$ ) at 25 °C reference temperature and 101.325 kPa reference pressure.
- 2.13. "Stoddard solvent" means a homogeneous, transparent, petroleum distillate mixture of refined C<sub>7</sub>-C<sub>12</sub> hydrocarbons; with a flash point of at least 38 °C, a specific gravity of  $0.78 \pm 0.03$  and a dynamic viscosity of  $0.9 \pm 0.05 \text{ mPa}\cdot\text{s}$  at 25 °C.
- 2.14. "Test attitude" means the pitch and roll angle of the test vehicle to be impacted with the pole.
- 2.15. "Unladen attitude" means the pitch and roll angle of the unladen vehicle when positioned on a level surface with all tyres fitted and inflated as recommended by the vehicle manufacturer.
- 2.16. "Unladen vehicle mass" is defined in Special Resolution 1.
- 2.17. "Useable fuel tank capacity" means the fuel tank capacity specified by the vehicle manufacturer.
- 2.18. "Vehicle master control switch" means the device by which the vehicle's on-board electronics system is brought from being switched off, as is the case when the vehicle is parked without the driver present, to the normal operating mode.
- 2.19. "Vehicle fuel" means the optimum fuel recommended by the vehicle manufacturer for the applicable fuel system.

### **3. Test equipment**

- 3.1. Test vehicle preparation area
- 3.1.1. An enclosed temperature controlled area suitable for ensuring stabilization of the test dummy temperature prior to testing.
- 3.2. Pole
- 3.2.1. A pole satisfying the definition of paragraph 2.8. of this annex, and offset from any mounting surface, such as a barrier or other structure, so that the test vehicle will not contact such a mount or support at any time within 100 ms of the initiation of vehicle-to-pole contact.

- 3.3. Anthropomorphic Test Devices
- 3.3.1. A WorldSID 50<sup>th</sup> percentile adult male dummy in accordance with Addendum 2 of Mutual Resolution No. 1 and fitted with (as a minimum) all instrumentation required to obtain the data channels necessary to determine the dummy performance criteria listed in paragraph 4.2. of this regulation. <sup>1</sup>

#### **4. Vehicle preparation**

- 4.1. Fuel systems designed for fuel with a boiling point above 0 °C shall be prepared in accordance with paragraphs 4.1.1. and 4.1.2.
- 4.1.1. The fuel tank shall be filled with fuel ballast<sup>2</sup> of mass:
  - 4.1.1.1. Greater than or equal to the mass of the vehicle fuel required to fill 90 per cent of the useable fuel tank capacity; and
  - 4.1.1.2. Less than or equal to the mass of the vehicle fuel required to fill 100 per cent of the useable fuel tank capacity.
- 4.1.2. Fuel ballast shall be used to fill the entire fuel system from the fuel tank through to the engine induction system.
- 4.2. Hydrogen fuel systems shall be prepared in accordance with the applicable post-crash fuel system integrity test procedures specified in the global technical regulation on hydrogen and fuel cell vehicles (ECE/TRANS/180/Add.13).
- 4.3. The other (non-fuel) liquid containing vehicle systems may be empty, in which case, the mass of the liquids (e.g. brake fluid, coolant, transmission fluid) shall be replaced by the equivalent ballast mass.
- 4.4. The vehicle test mass, including the mass of the necessary anthropomorphic test device and any ballast mass, shall be within +0/-10 kg of the laden mass defined in paragraph 2.6. of this annex.
- 4.5. The pitch angles measured on the left and right side of the vehicle in the test attitude shall be between the corresponding (left or right as applicable) unladen attitude pitch angle and laden attitude pitch angle, inclusive.
- 4.6. Each linear reference used to measure the unladen, laden and test attitude pitch angles on the left or right side of the vehicle in paragraph 4.5. above shall connect the same fixed reference points on the left or right (as applicable) side door sill.
- 4.7. The roll angles measured at the front and rear of the vehicle in the test attitude shall be between the corresponding (front or rear as applicable) unladen attitude roll angle and laden attitude roll angle, inclusive.

---

<sup>1</sup> Addendum 2 of Mutual Resolution No.1 is under development. For progress on the development of Addendum 2 to Mutual Resolution No.1, refer to the UNECE Working Party on Passive Safety (GRSP) website, at [www.unece.org/trans/main/welcwp29.html](http://www.unece.org/trans/main/welcwp29.html).

<sup>2</sup> For safety reasons, flammable liquids with a flash point below 38 °C are not recommended for use as fuel ballast.



- 4.8. Each linear reference used to measure the unladen, laden and test attitude roll angles at the front or rear of the vehicle in paragraph 4.7. above shall connect the same fixed reference points on the front or rear (as applicable) vehicle body.

## **5. Vehicle passenger compartment adjustments**

- 5.1. Adjustable front-row seats
- 5.1.1. Any seat adjustment, including any seat cushion, seatback, armrest, lumbar support, and head restraint; of a front-row outboard seating position on the impact side of the vehicle; shall be placed in the position of adjustment specified in Annex 2.
- 5.2. Adjustable front-row safety-belt anchorages
- 5.2.1. Any adjustable safety-belt anchorage(s) provided for a front-row outboard seating position on the impact side of the vehicle, shall be placed in the position of adjustment specified in Annex 2.
- 5.3. Adjustable steering wheels
- 5.3.1. Any adjustable steering wheel shall be placed in the position of adjustment specified in Annex 2.
- 5.4. Convertible tops
- 5.4.1. Convertibles and open-body type vehicles shall have the top, if any, in place in the closed passenger compartment configuration.
- 5.5. Doors
- 5.5.1. Doors, including any back door (e.g. a hatchback or tailgate), shall be fully closed and fully latched, but not locked.
- 5.6. Parking brake
- 5.6.1. The parking brake shall be engaged.
- 5.7. Electrical system
- 5.7.1. The vehicle master control switch shall be in the "on" position.
- 5.8. Pedals
- 5.8.1. Any adjustable pedals shall be placed as specified in Annex 2.
- 5.9. Windows, vents and sunroofs
- 5.9.1. Moveable vehicle windows and vents located on the impact side of the vehicle shall be placed in the fully closed position.
- 5.9.2. Any sunroof(s) shall be placed in the fully closed position.

## **6. Dummy preparation and positioning**

- 6.1. A WorldSID 50<sup>th</sup> percentile adult male dummy in accordance with paragraph 3.3.1. of this annex shall be installed in accordance with Annex 2, in the front-row outboard seat located on the impact side of the vehicle.
- 6.2. The test dummy shall be configured and instrumented to be struck on the side closest to the side of the vehicle impacting the pole.

- 6.3. The stabilised temperature of the test dummy at the time of the test shall be between 20.6 °C and 22.2 °C.
- 6.4. A stabilised dummy temperature shall be obtained by soaking the dummy at controlled test laboratory environment temperatures within the range specified in paragraph 6.3. above prior to the test.
- 6.5. The stabilised temperature of the test dummy shall be recorded by an internal dummy chest cavity temperature sensor.

## **7. Vehicle-to-pole side impact test**

- 7.1. Except as provided in paragraph 7.2., a test vehicle prepared in accordance with paragraph 4., paragraph 5. and paragraph 6. of this annex, shall be impacted into a stationary pole at any speed up to and including 32 km/h.<sup>3</sup>
- 7.2. The maximum test speed may be reduced to 26 km/h for vehicles with a width of 1.50 m or less.<sup>4</sup>
- 7.3. The test vehicle shall be propelled so that, when the vehicle-to-pole contact occurs, the direction of vehicle motion forms an angle of  $75^{\circ} \pm 3^{\circ}$  with the vehicle longitudinal centreline.
- 7.4. The angle in paragraph 7.3. above shall be measured between the vehicle longitudinal centreline and a vertical plane parallel to the vehicle impact velocity vector, as indicated in Annex 5, Figure 5-1 (or Figure 5-2) for left (or right) side impact.
- 7.5. The impact reference line shall be aligned with the centreline of the rigid pole surface, as viewed in the direction of vehicle motion, so that, when the vehicle-to-pole contact occurs, the centreline of the pole surface contacts the vehicle area bounded by two vertical planes parallel to and 25 mm forward and aft of the impact reference line.
- 7.6. During the acceleration phase of the test prior to first contact between the vehicle and the pole, the acceleration of the test vehicle shall not exceed  $1.5 \text{ m/s}^2$ .

---

<sup>3</sup> See Part I for a recommendation of how this "any speed up to and including 32 km/h" requirement should be implemented in a Regulation of the 1958 Agreement or the domestic legislation of a Contracting Party implementing this regulation in a type approval based regulatory system.

<sup>4</sup> Contracting parties selecting this option shall notify the Secretary General in writing when submitting the notification required by Article 7.2. of the 1998 Agreement.

## Annex 2

### Seat adjustment and installation requirements for the WorldSID 50<sup>th</sup> percentile adult male dummy

#### 1. Purpose

Repeatable and reproducible front-row seat installation of the WorldSID 50<sup>th</sup> percentile adult male dummy in a vehicle seat position and automotive seating posture representative of a typical mid-size adult male.

#### 2. Definitions

For the purposes of this annex:

- 2.1. "*Actual torso angle*" means the angle measured between a vertical line through the manikin H-point and the torso line using the back angle quadrant on the 3-D H machine.
- 2.2. "*Centre plane of occupant (C/LO)*" means the median plane of the 3-D H machine positioned in each designated seating position. It is represented by the lateral (Y-axis) coordinate of the H-point in the vehicle reference coordinate system. For individual seats, the vertical median plane of the seat coincides with the centre plane of the occupant. For driver bench seating positions, the centre plane of the occupant coincides with the geometric centre of the steering wheel hub. For other seats, the centre plane of the occupant is specified by the manufacturer.
- 2.3. "*Design rib angle*" means the nominal (theoretical) angle of the WorldSID 50<sup>th</sup> percentile adult male middle thorax, lower thorax and abdominal ribs relative to a level surface or horizontal reference plane, as defined by the manufacturer for the final adjustment position of the seat in which the dummy is to be installed. The design rib angle corresponds theoretically to the design torso angle minus 25°.
- 2.4. "*Design torso angle*" means the angle measured between a vertical line through the manikin H-point and the torso line in a position which corresponds to the nominal design position of the seat back for a 50<sup>th</sup> percentile adult male occupant established by the vehicle manufacturer.
- 2.5. "*Dummy H-point*" means the coordinate point midway between the H-point locator assembly measurement points on each side of the test dummy pelvis.<sup>1</sup>
- 2.6. "*Dummy rib angle*" means the angle of the test dummy middle thorax, lower thorax and abdominal ribs relative to a level surface or horizontal reference plane as established by the thorax tilt sensor angle reading about the sensor y-axis. The dummy rib angle corresponds theoretically to the actual torso angle minus 25°.

---

<sup>1</sup> Details of the H-point locator assembly (H-point tool) including drawings and dimensions are available in Addendum 2 of Mutual Resolution No. 1.

- 2.7. "Fiducial marks" are physical points (holes, surfaces, marks or indentations) on the vehicle body.
- 2.8. "Leg (for dummy installation purposes)" refers to the lower part of the entire leg assembly between, and including, the foot and the knee assembly.
- 2.9. "Manikin H-point" means the pivot centre of the torso and thigh of the 3-D H machine when installed in a vehicle seat in accordance with paragraph 6. of this annex. The manikin H-point is located at the centre of the centreline of the device, between the H-point sight buttons on either side of the 3-D H machine. Once determined in accordance with the procedure described in paragraph 6. of this annex, the manikin H-point is considered fixed in relation to the seat cushion support structure and is considered to move with it when the seat is adjusted.
- 2.10. "Mid-sagittal plane" means the median plane of the test dummy; located midway between and parallel to the dummy spine box side plates.
- 2.11. "Muslin cotton" means a plain cotton fabric having 18.9 threads per cm<sup>2</sup> and weighing 0.228 kg/m<sup>2</sup> or knitted or non-woven fabric having comparable characteristics.
- 2.12. "Seat cushion reference line" means a planar line along the side surface of the seat cushion base and passing through the SCRCP defined in paragraph 2.14. of this annex. The seat cushion reference line may be marked on the side of a seat cushion support structure and/or its position defined using an additional reference point. The projection of the seat cushion reference line to a vertical longitudinal plane is linear (i.e. straight).
- 2.13. "Seat cushion reference line angle" means the angle of the seat cushion reference line projection in a vertical longitudinal plane, relative to a level surface or horizontal reference plane.
- 2.14. "Seat cushion reference point" (SCRCP) means the measurement point identified, placed or marked on the outboard side of a seat cushion support structure to record the longitudinal (fore/aft) and vertical travel of an adjustable seat cushion.
- 2.15. "Shoulder median plane" means a plane dividing the left or right (as applicable) shoulder clevis into symmetrical anterior/posterior sections. The shoulder median plane is perpendicular to the centreline of the shoulder pivot shaft and parallel to the shoulder load cell y-axis (or an equivalently oriented axis of a shoulder load cell structural replacement).
- 2.16. "Thigh (for dummy installation purposes)" refers to the distal upper leg flesh section of the test dummy between, but not including, the knee assembly and the pelvis flesh.
- 2.17. "Three-dimensional H-point machine" (3-D H machine) means the device used for the determination of manikin H-points and actual torso angles. This device is defined in Annex 3.
- 2.18. "Torso line" means the centreline of the probe of the 3-D H machine with the probe in the fully rearward position.
- 2.19. "Vehicle measuring attitude" means the position of the vehicle body as defined by the coordinates of at least three fiducial marks; sufficiently separated in the longitudinal (X), transverse (Y) and vertical (Z) axes of the vehicle reference coordinate system, to enable accurate alignment with the measurement axes of a coordinate measurement machine. The vehicle

measuring attitude is established by positioning the test vehicle, on a level surface; and adjusting the attitude of the test vehicle such that the vehicle longitudinal centre plane is parallel to the vertical longitudinal zero plane and the front left and right door sill pitch angles satisfy the vehicle test attitude requirements of paragraph 4.5. of Annex 1.

- 2.20. "*Vehicle reference coordinate system*" means an orthogonal coordinate system consisting of three axes; a longitudinal axis (X), a transverse axis (Y), and a vertical axis (Z). X and Y are in the same horizontal plane and Z passes through the intersection of X and Y. The X-axis is parallel to the longitudinal centre plane of the vehicle.
- 2.21. "*Vertical longitudinal plane*" means a vertical plane, parallel to the vehicle longitudinal centreline.
- 2.22. "*Vertical longitudinal zero plane*" means a vertical longitudinal plane passing through the origin of the vehicle reference coordinate system.
- 2.23. "*Vertical plane*" means a vertical plane, not necessarily perpendicular or parallel to the vehicle longitudinal centreline.
- 2.24. "*Vertical transverse plane*" means a vertical plane, perpendicular to the vehicle longitudinal centreline.
- 2.25. "*WS50M H-point*" means the coordinate point located 20 mm longitudinally forward in the vehicle reference coordinate system of the manikin H-point determined in accordance with paragraph 6. of this annex.

### **3. Seat comfort and head restraint adjustments**

- 3.1. Where applicable, the test seat adjustments specified in paragraphs 3.1.1. to 3.1.3. shall be performed on the seat in which the dummy is to be installed.
  - 3.1.1. Adjustable lumbar supports
    - 3.1.1.1. Any adjustable lumbar support(s) shall be adjusted so that the lumbar support is in the lowest, retracted or most deflated adjustment position.
    - 3.1.2. Other adjustable seat support systems
      - 3.1.2.1. Any other adjustable seat supports, such as seat cushions adjustable in length and leg support systems, shall be adjusted to the rearmost or most retracted adjustment position.
  - 3.1.3. Head restraints
    - 3.1.3.1. The head restraint shall be adjusted to the vehicle manufacturer's nominal design position for a 50<sup>th</sup> percentile adult male occupant or the uppermost position if no design position is available.

### **4. Passenger compartment adjustments**

- 4.1. Where applicable, the adjustment specified in paragraph 4.1.1. of this annex; and in the case where the dummy is to be installed on the driver's side, the adjustments specified in paragraphs 4.1.2. and 4.1.3. of this annex; shall be performed on the vehicle.

- 4.1.1. Adjustable safety-belt anchorages
  - 4.1.1.1. Any adjustable safety-belt anchorage(s) provided for the seating position at which the dummy is to be installed, shall be placed at the vehicle manufacturer's nominal design position for a 50<sup>th</sup> percentile adult male occupant, or in the fully up position if no design position is available.
- 4.1.2. Adjustable steering wheels
  - 4.1.2.1. An adjustable steering wheel shall be adjusted to the geometric highest driving position, considering all telescopic and tilt adjustment positions available.<sup>2</sup>
- 4.1.3. Adjustable pedals
  - 4.1.3.1. Any adjustable pedals shall be placed in the full forward position (i.e. towards the front of the vehicle).

## **5. Procedure for establishing the test position of an adjustable seat cushion**

- 5.1. A seat cushion reference point (SCRCP) shall be used to measure and record adjustments made to seat cushions equipped with controls for longitudinal (fore/aft) and/or vertical seat cushion adjustment.
- 5.2. The SCRCP should be located on a part of the seat cushion side structure or support frame which is fixed in location with respect to the seat cushion.
- 5.3. A seat cushion reference line shall be used to measure and record angular adjustments made to pitch adjustable seat cushions.
- 5.4. For pitch adjustable seat cushions, the SCRCP location should be set as close as possible to the axis of rotation (e.g. towards the rear) of the seat cushion support structure.
- 5.5. The adjustment position of the seat cushion base on which the dummy is to be installed shall be determined by sequential completion (where applicable to the seat design) of the steps outlined in paragraphs 5.6. to 5.13. of this annex below; with the test vehicle at the vehicle measuring attitude defined in paragraph 2.19. of this annex above.
- 5.6. Use the seat control that primarily moves the seat vertically to adjust the SCRCP to the uppermost vertical location.
- 5.7. Use the seat control that primarily moves the seat fore/aft to adjust the SCRCP to the rearmost location.
- 5.8. Determine and record (by measuring the seat cushion reference line angle), the full angular adjustment range of the seat cushion pitch and using only the control(s) that primarily adjust(s) the cushion pitch, set the cushion pitch as close as possible to the mid-angle.
- 5.9. Use the seat control that primarily moves the seat vertically to adjust the SCRCP to the lowest vertical location. Verify that the seat cushion is still at the rearmost seat track location. Record the longitudinal (X-axis) position of the SCRCP in the vehicle reference coordinate system.

---

<sup>2</sup> The steering wheel is not expected to influence the loading of the dummy – the highest position is specified in order to provide maximum clearance of the dummy legs and thorax.

- 5.10. Use the seat control that primarily moves the seat fore/aft to adjust the SCRP to the forward most location. Record the longitudinal (X-axis) position of the SCRP in the vehicle reference coordinate system.
- 5.11. Determine the vehicle X-axis position of a vertical transverse plane 20 mm rearward of a point midway between the longitudinal (X-axis) positions recorded in accordance with paragraphs 5.9. and 5.10. above (i.e. 20 mm rearward of the mid-track position).
- 5.12. Use the seat control that primarily moves the seat fore/aft to adjust the SCRP to the longitudinal (X-axis) position determined in accordance with paragraph 5.11. (-0/+2 mm), or, if this is not possible, the first available fore/aft adjustment position rearward of the position determined in accordance with paragraph 5.11.
- 5.13. Record the longitudinal (X-axis) position of the SCRP in the vehicle reference coordinate system and measure the seat cushion reference line angle for future reference. Except as provided in paragraph 7.4.6. of this annex; this adjustment position shall be used as the final seat cushion adjustment position for the installation of the dummy.<sup>3</sup>

## **6. Procedure for manikin H-point and actual torso angle determination**

- 6.1. The test vehicle shall be preconditioned at a temperature of 20 °C ± 10 °C to ensure that the seat material reaches stabilised room temperature for the installation of the 3-D H machine.
- 6.2. Adjustable lumbar supports and other adjustable seat supports shall be set to the adjustment positions specified in paragraph 3.1.1. and 3.1.2. of this annex.
- 6.3. The manikin H-point coordinates and final actual torso angle shall be determined for the seat in which the dummy is to be installed, by sequential completion of the steps outlined in paragraphs 6.4. to 6.24. of this annex below; with the test vehicle at the vehicle measuring attitude defined in paragraph 2.19. of this annex above.
- 6.4. Cover the area of the seating position to be contacted by the 3-D H machine with a muslin cotton sheet of sufficient size and place the seat and back assembly of the 3-D H machine in the seat.
- 6.5. Set the seat cushion position to the adjustment position recorded in accordance with paragraph 5.13. of this annex.
- 6.6. Using only the control(s) which primarily adjusts the angle of the seat back, independently of the seat cushion pitch; adjust the seat back position according to one of the following methods:
  - 6.6.1. Place adjustable seat backs in the manufacturer's nominal design driving or riding position for a 50<sup>th</sup> percentile adult male occupant, in the manner specified by the manufacturer.
  - 6.6.2. Where a design seat back position is not specified by the manufacturer:

---

<sup>3</sup> For some seats, the adjustments specified in paragraphs 5.9. to 5.12. may automatically alter the seat cushion pitch from the mid-angle established in accordance with paragraph 5.8. This is acceptable.

- 6.6.2.1. Set the seat back to the first detent position rearward of 25° from the vertical.
- 6.6.2.2. If there is no detent position rearward of 25° from the vertical, set the seat back angle to the most reclined adjustment position.
- 6.7. Adjust the seat and back assembly of the 3-D H machine so that the centre plane of the occupant (C/LO) coincides with the centre plane of the 3-D H machine.
- 6.8. Set the lower leg segments to the 50<sup>th</sup> percentile length (417 mm) and the thigh bar segment to the 10<sup>th</sup> percentile length (408 mm).
- 6.9. Attach the foot and lower leg assemblies to the seat pan assembly, either individually or by using the T-bar and lower leg assembly. The line through the H-point sight buttons should be parallel to the ground and perpendicular to the C/LO of the seat.
- 6.10. Adjust the feet and leg positions of the 3-D H machine as follows:
  - 6.10.1. Both feet and leg assemblies are moved forward in such a way that the feet take up natural positions on the floor, between the operating pedals if necessary. Where possible, the left foot is located approximately the same distance to the left of the centre plane of the 3-D H machine as the right foot is to the right. The spirit level verifying the transverse orientation of the 3-D H machine is brought to the horizontal by readjustment of the seat pan if necessary, or by adjusting the leg and foot assemblies towards the rear. The line passing through the H-point sight buttons is maintained perpendicular to the C/LO of the seat.
  - 6.10.2. If the left leg cannot be kept parallel to the right leg and the left foot cannot be supported by the structure, move the left foot until it is supported. The alignment of the sight buttons is maintained.
- 6.11. Apply the lower leg and thigh weights and level the 3-D H machine.
- 6.12. Tilt the back pan forward against the forward stop and draw the 3-D H machine away from the seat back using the T-bar. Reposition the 3-D H machine on the seat by one of the following methods:
  - 6.12.1. If the 3-D H machine tends to slide rearward, use the following procedure. Allow the 3-D H machine to slide rearward until a forward horizontal restraining load on the T-bar is no longer required (i.e. until the seat pan contacts the seat back). If necessary, reposition the lower leg.
  - 6.12.2. If the 3-D H machine does not tend to slide rearward, use the following procedure. Slide the 3-D H machine rearwards by applying a horizontal rearward load to the T-bar until the seat pan contacts the seat back (see Figure 3-2 of Annex 3).
- 6.13. Apply a 100 N ± 10 N load to the back and pan assembly of the 3-D H machine at the intersection of the hip angle quadrant and the T-bar housing. The direction of load application is maintained along a line passing by the above intersection to a point just above the thigh bar housing (see Figure 3-2 of Annex 3). Then carefully return the back pan to the seat back. Care must be exercised throughout the remainder of the procedure to prevent the 3-D H machine from sliding forward.
- 6.14. Install the right and left buttock weights and then, alternately, the eight torso weights. Maintain the 3-D H machine level.



- 6.15. Tilt the back pan forward to release the tension on the seat back. Rock the 3-D H machine from side to side through 10 degrees arc (5 degrees to each side of the vertical centre plane) for three complete cycles to release any accumulated friction between the 3-D H machine and the seat.
- 6.15.1. During the rocking action, the T-bar of the 3-D H machine may tend to diverge from the specified horizontal and vertical alignment. The T-bar must therefore be restrained by applying an appropriate lateral load during the rocking motions. Care is exercised in holding the T-bar and rocking the 3-D H machine to ensure that no inadvertent exterior loads are applied in a vertical or fore and aft directions.
- 6.15.2. The feet of the 3-D H machine are not to be restrained or held during this step. If the feet change position, they should be allowed to remain in that attitude for the moment.
- 6.16. Carefully return the back pan to the seat back and check the two spirit levels for zero position. If any movement of the feet has occurred during the rocking operation of the 3-D H machine, they must be repositioned as follows:
- 6.16.1. Alternately, lift each foot off the floor the minimum necessary amount until no additional foot movement is obtained. During this lifting, the feet are to be free to rotate; and no forward or lateral loads are to be applied. When each foot is placed back in the down position, the heel is to be in contact with the structure designed for this.
- 6.17. Check the lateral spirit level for zero position; if necessary, apply a lateral load to the top of the back pan sufficient to level the 3-D H machine's seat pan on the seat.
- 6.18. Holding the T-bar to prevent the 3-D H machine from sliding forward on the seat cushion, proceed as follows:
- 6.18.1. Return the back pan to the seat back; and
- 6.18.2. Alternately apply and release a horizontal rearward load, not to exceed 25 N, to the back angle bar at a height approximately at the centre of the torso weights until the hip angle quadrant indicates that a stable position has been reached after load release. Care is exercised to ensure that no exterior downward or lateral loads are applied to the 3-D H machine. If another level adjustment of the 3-D H machine is necessary, rotate the back pan forward, re-level, and repeat all procedures from paragraph 6.15. of this annex onwards.
- 6.19. Use the 3-D H machine back angle quadrant, with the head room probe in its fully rearward position, to measure the actual torso angle.
- 6.20. If necessary, use only the control(s) which primarily adjusts the angle of the seat back independently of the seat cushion pitch; to adjust the actual torso angle to the design torso angle  $\pm 1^\circ$  specified by the manufacturer.
- 6.21. Where a design torso angle is not specified by the manufacturer:
- 6.21.1. Use only the control(s) which primarily adjusts the angle of the seat back independently of the seat cushion pitch; to adjust the actual torso angle to  $23^\circ \pm 1^\circ$ .
- 6.22. Where a design torso angle is not specified by the manufacturer and no seat back angular adjustment position produces an actual torso angle within the  $23^\circ \pm 1^\circ$  range:

- 6.22.1. use only the control(s) which primarily adjusts the angle of the seat back independently of the seat cushion pitch; to adjust the actual torso angle as close to 23° as possible.
- 6.23. Record the final actual torso angle for future reference.
- 6.24. Measure and record the manikin H-point (X, Y, Z) coordinates in the vehicle reference coordinate system for future reference.
- 6.25. Except as provided in paragraph 7.4.6. of this annex; the coordinates recorded in accordance with paragraph 6.24. above define the manikin H-point location of the seat, when the seat is adjusted to the final seat cushion and seat back detent test positions for the installation of the dummy.
- 6.26. If a rerun of the installation of the 3-D H machine is desired, the seat assembly should remain unloaded for a minimum period of 30 minutes prior to the rerun. The 3-D H machine should not be left loaded on the seat assembly longer than the time required to perform the test.

## **7. WorldSID 50<sup>th</sup> percentile adult male installation requirements**

- 7.1. Adjustable lumbar supports, other adjustable seat supports and adjustable head restraints shall be set to the adjustment positions specified in paragraph 3. of this annex.
- 7.2. Passenger compartment adjustments shall be set to the adjustment positions specified in paragraph 4. of this annex.
- 7.3. The test dummy shall then be installed by completion of the steps outlined in paragraph 7.4. below; with the test vehicle at the vehicle measuring attitude defined in paragraph 2.19. of this annex above.
- 7.4. Dummy installation procedure
  - 7.4.1. Place the test dummy in the applicable seat such that the mid-sagittal plane is coincident with the C/LO and the upper torso is resting against the seat back.<sup>4</sup>
  - 7.4.2. Apply a for/aft and lateral rocking motion to settle the pelvis rearward in the seat.<sup>5</sup>
  - 7.4.3. Where the abdominal rib coupler and/or the outer band of each (i.e. left/right) lower abdominal rib assembly contacts the pelvis flesh, ensure the contacting surfaces of the abdominal rib coupler and the outer band of each lower abdominal rib are positioned in-behind the inner abdominal wall of the pelvis flesh, not on top of the pelvis flesh.
  - 7.4.4. Move the seat cushion and seat back together with the test dummy to the final adjustment position used to determine the manikin H-point and actual torso angle in paragraph 6. of this annex.

---

<sup>4</sup> Seat centreline markings may be used to identify the C/LO and to facilitate placement of the dummy.

<sup>5</sup> To ensure that a repeatable and stable pelvis position will be achieved, it is recommended following the completion of this step, to verify that the pelvis is in contact with the seat cushion over the whole pelvis length.

- 7.4.5. Verify that the dummy H-point is reasonably close ( $\pm 10$  mm) to the WS50M H-point defined in paragraph 2.25. of this annex. If not, repeat the procedures outlined in paragraphs 7.4.2. to 7.4.3. of this annex. If it is still not possible to verify the dummy H-point is reasonably close ( $\pm 10$  mm) to the WS50M H-point, record the offset and proceed to the next step.
- 7.4.6. If it is not possible to reach the seat test position due to knee contact, shift the targeted test seat position rearwards in stepwise increments to the closest position where the knee clearance is at least 5 mm. Record the adjustment of the SCRIP position and modify the manikin H-point and WS50M H-point coordinates accordingly.
- 7.4.7. For a driver seating position:
- 7.4.7.1. Extend the right leg without displacing the thigh from the seat cushion and allow the sole of the foot to settle on the accelerator pedal. The heel of the shoe should be in contact with the floor-pan.
- 7.4.7.2. Extend the left leg without displacing the thigh from the seat cushion and allow the sole of the foot to settle on the footrest. The heel of the shoe should be in contact with the floor-pan. In case of tibia contact, slide the foot rearward (towards the seat) until a 5 mm clearance is obtained.
- 7.4.8. For a passenger seating position:
- 7.4.8.1. Extend each leg without displacing the thigh from the seat cushion.
- 7.4.8.2. Allow the sole of the right foot to settle on the floor-pan in-line (i.e. in the same vertical plane) with the thigh. The heel of the shoe should be in contact with the floor-pan. If the contour of the floor-pan does not permit the foot to rest on a planar surface, move the foot in 5 mm increments until the foot rests on a planar surface.
- 7.4.8.3. Allow the sole of the left foot to settle on the floor-pan in-line (i.e. in the same vertical plane) with the thigh and in the same for/aft location (alignment) as the right foot. The heel of the shoe should be in contact with the floor-pan. If the contour of the floor-pan does not permit the foot to rest on a planar surface, move the foot in 5 mm increments until the foot rests on a planar surface.
- 7.4.9. Position the dummy H-point to match the WS50M H-point coordinates (defined by paragraph 2.25. of this annex) within  $\pm 5$  mm. Priority should be given to the X-axis coordinate.
- 7.4.10. Adjust the dummy rib angle as follows:
- 7.4.10.1. Adjust the dummy until the thorax tilt sensor angle reading (about the sensor y-axis) is within  $\pm 1^\circ$  of the design rib angle specified by the manufacturer.
- 7.4.10.2. Where a design rib angle is not specified by the manufacturer and the final actual torso angle determined in accordance with paragraph 6. of this annex is  $23^\circ \pm 1^\circ$ ; adjust the dummy until the thorax tilt sensor reads  $-2^\circ$  (i.e.  $2^\circ$  downwards)  $\pm 1^\circ$  (about the sensor y-axis).
- 7.4.10.3. Where a design rib angle is not specified by the manufacturer and the final actual torso angle recorded in accordance with paragraph 6. of this annex is not  $23^\circ \pm 1^\circ$ ; no further adjustment of the dummy rib angle is required.
- 7.4.11. Adjust the test dummy neck bracket to level the head at the closest position to  $0^\circ$  (as measured about the head core tilt sensor y-axis).

- 7.4.12. Proceed to the final foot and leg positioning by repeating the steps outlined in paragraph 7.4.7. of this annex for a driver seating position or the steps outlined in paragraph 7.4.8. of this annex for a passenger seating position.
- 7.4.13. Verify that the test dummy H-point and dummy rib angle are still in accordance with paragraphs 7.4.9. and 7.4.10. of this annex respectively. If not, repeat the steps outlined from paragraph 7.4.9. of this annex onwards.
- 7.4.14. Measure and record the final test dummy H-point position in the vehicle reference coordinate system and record the final dummy rib angle and head core tilt sensor angles.
- 7.4.15. Place both arms at the 48° detent position. In this position, each half arm bone plane of symmetry forms an angle of  $48^\circ \pm 1^\circ$  with the adjacent (i.e. left/right as applicable) shoulder median plane.
- 7.5. Dummy installation notes and recommendations
  - 7.5.1. No distance is specified for the test dummy knee spacing. However, priority should be given to ensure:
    - 7.5.1.1. At least 5 mm clearance between the knees/legs and the steering shroud and centre console;
    - 7.5.1.2. A stable foot and ankle position; and
    - 7.5.1.3. The legs are as parallel as possible to the mid-sagittal plane.
- 7.6. Safety-belt system
  - 7.6.1. The dummy installed in accordance with paragraph 7.4. of this annex shall be restrained as follows using the safety-belt system provided for the seating position by the manufacturer:
    - 7.6.1.1. Carefully place the safety-belt across the dummy and fasten as normal.
    - 7.6.1.2. Remove slack from the lap section of the webbing until it is resting gently around the pelvis of the dummy. Only minimal force should be applied to the webbing when removing slack. The route of the lap-belt should be as natural as possible.
    - 7.6.1.3. Place one finger behind the diagonal section of the webbing at the height of the dummy sternum. Pull the webbing horizontally forward and away from the chest, and utilizing the force provided by the retractor mechanism only, allow it to freely retract in the direction of the upper anchorage. Repeat this step three times.

## Annex 3

### Description of the three-dimensional H-point machine<sup>1</sup> (3-D H machine)

#### 1. Back and seat pans

The back and seat pans are constructed of reinforced plastic and metal; they simulate the human torso and thigh and are mechanically hinged at the H-point. A quadrant is fastened to the probe hinged at the H-point to measure the actual torso angle. An adjustable thigh bar, attached to the seat pan, establishes the thigh centreline and serves as a baseline for the hip angle quadrant.

#### 2. Body and leg elements

Lower leg segments are connected to the seat pan assembly at the T-bar joining the knees, which is a lateral extension of the adjustable thigh bar. Quadrants are incorporated in the lower leg segments to measure knee angles. Shoe and foot assemblies are calibrated to measure the foot angle. Two spirit levels orient the device in space. Body element weights are placed at the corresponding centres of gravity to provide seat penetration equivalent to a 76 kg male. All joints of the 3-D H machine should be checked for free movement without encountering noticeable friction.

---

<sup>1</sup> For details of the construction of the 3-D H machine refer to SAE International (SAE), 400 Commonwealth Drive, Warrendale, Pennsylvania 15096, United States of America (SAE J826 1995 version). The machine corresponds to that described in ISO Standard 6549: 1999.

Figure 3-1  
3-D H machine elements designation

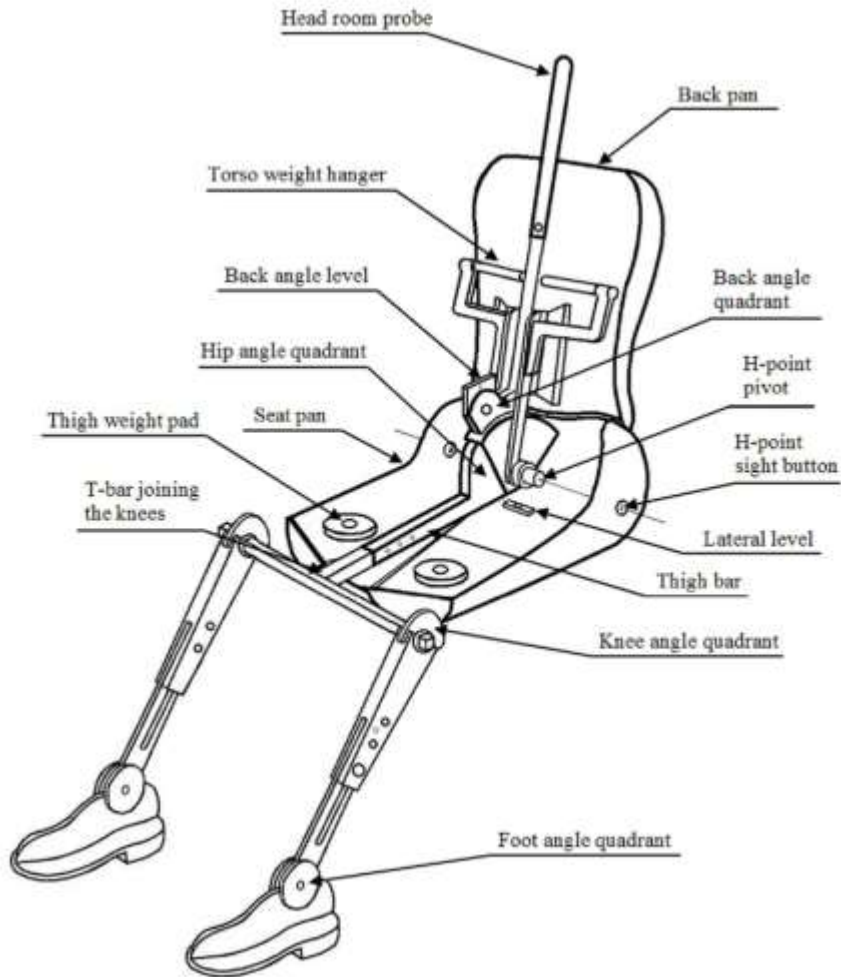
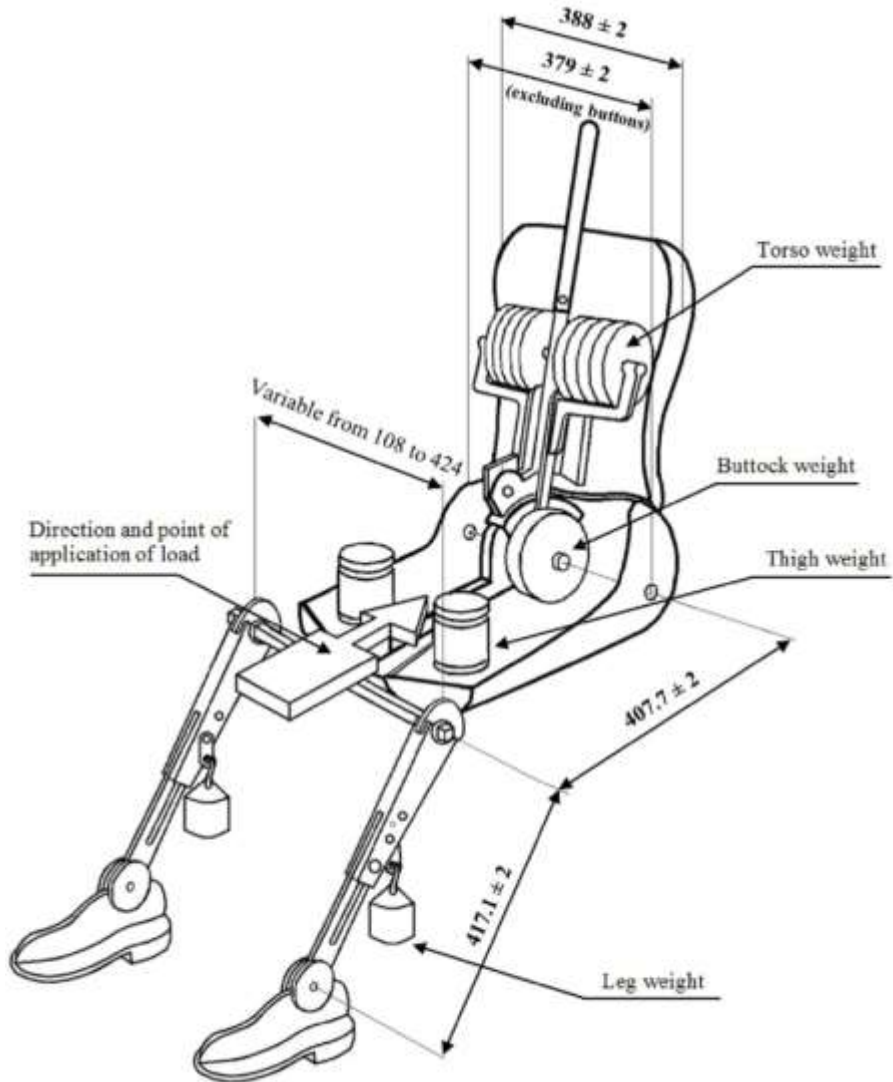

Figure 3-2  
Dimensions of the 3-D H machine elements and load distribution (Dimensions in millimetres)



## Annex 4

### Impact reference line

Figure 4-1  
Vehicle to be impacted on left side (overhead plan view)

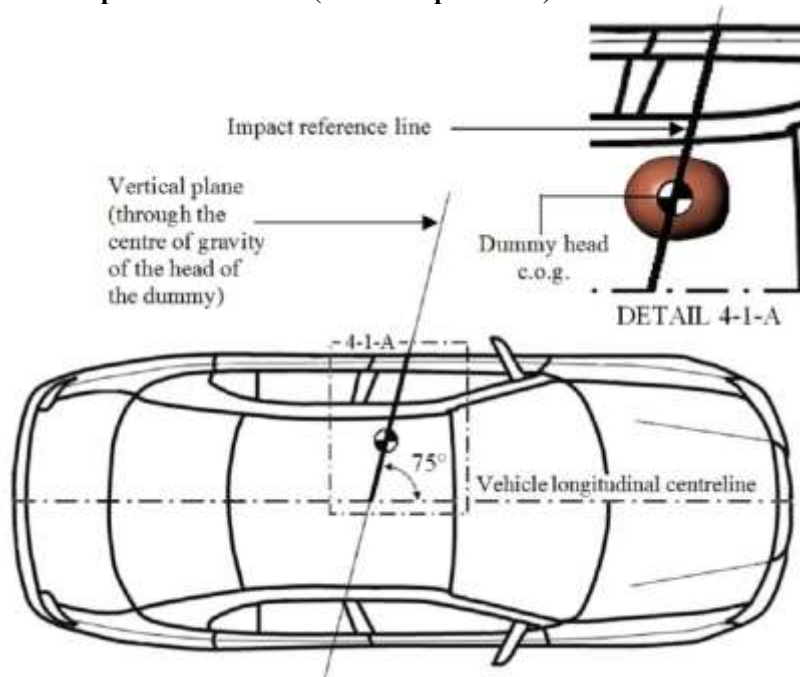
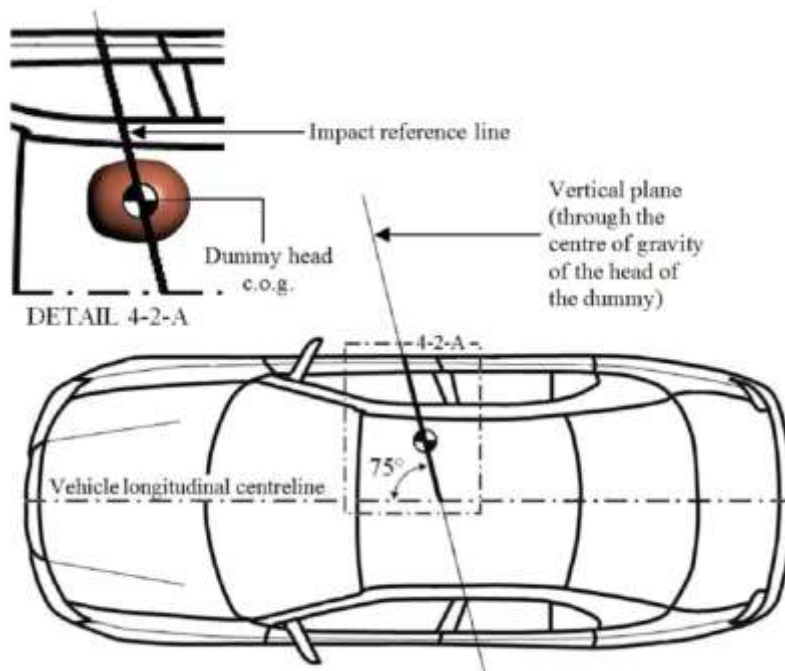

Figure 4-2  
Vehicle to be impacted on right side (overhead plan view)





## Annex 5

### Impact angle

Figure 5-1  
Left side impact (overhead plan view)

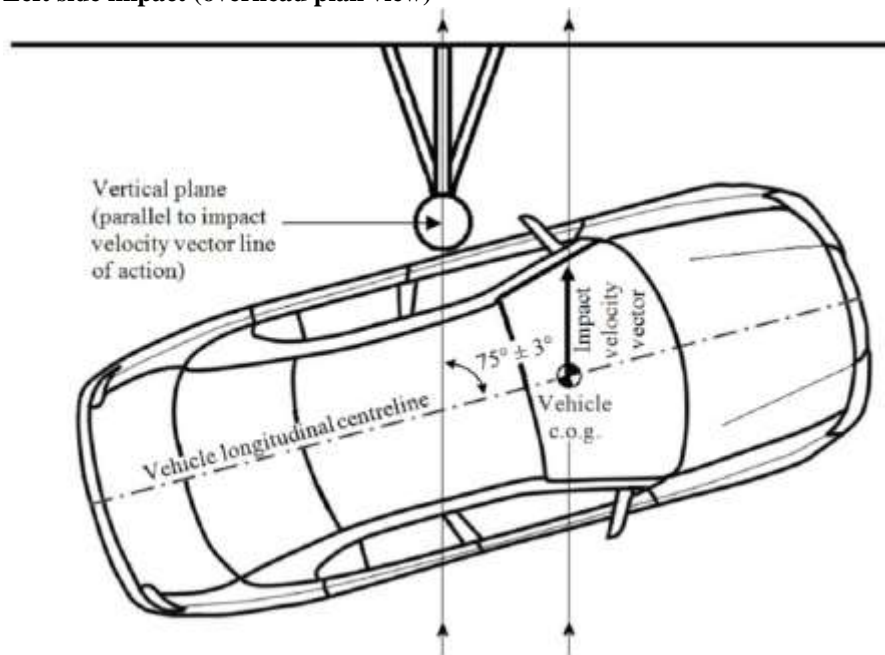
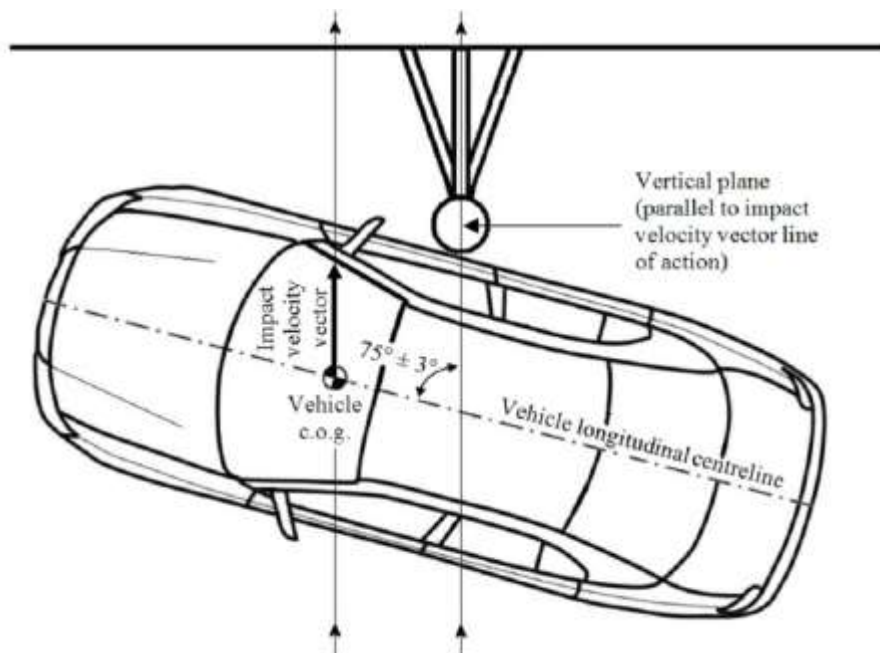

Figure 5-2  
Right side impact (overhead plan view)



## Annex 6

### Pitch and roll angle references

Figure 6-1  
Example of a linear reference connecting two reference points on a left door sill

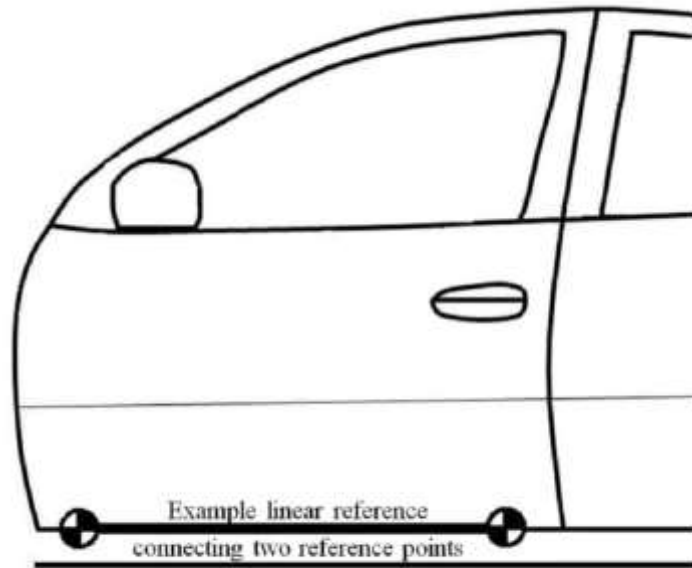
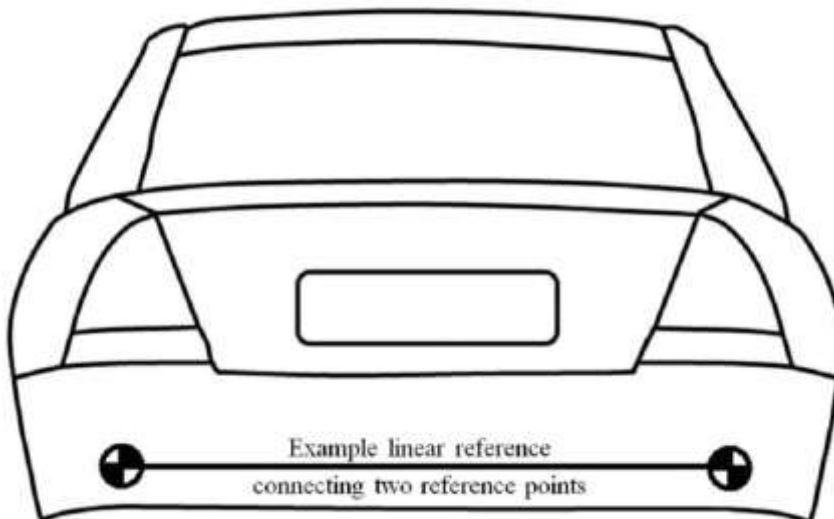

Figure 6-2  
Example of a linear reference connecting two reference points on a rear body



## Annex 7

### Determination of WorldSID 50<sup>th</sup> percentile adult male performance criteria

#### 1. Head Injury Criterion (HIC)

- 1.1. The Head Injury Criterion (HIC) 36 is the maximum value calculated from the expression:

$$\text{HIC36} = \left[ \frac{1}{t_2 - t_1} \int_{t_1}^{t_2} a_R dt \right]^{2.5} (t_2 - t_1)$$

Where:

$a_R$  = the resultant translational acceleration at the centre of gravity of the dummy head recorded versus time in units of gravity, g (1 g = 9.81 m/s<sup>2</sup>); and

$t_1$  and  $t_2$  are any two points in time during the impact which are separated by not more than a 36 millisecond time interval and where  $t_1$  is less than  $t_2$ .

- 1.2. The resultant acceleration at the centre of gravity of the dummy head is calculated from the expression:

$$a_R = \sqrt{a_x^2 + a_y^2 + a_z^2}$$

Where:

$a_x$  = the longitudinal (x-axis) acceleration at the centre of gravity of the dummy head recorded versus time and filtered at a channel frequency class (CFC)<sup>1</sup> of 1000 Hz;

$a_y$  = the lateral (y-axis) acceleration at the centre of gravity of the dummy head recorded versus time and filtered at a CFC of 1000 Hz; and

$a_z$  = the vertical (z-axis) acceleration at the centre of gravity of the dummy head recorded versus time and filtered at a CFC of 1000 Hz.

#### 2. Reserved

#### 3. Shoulder performance criteria

- 3.1. The peak lateral (y-axis) shoulder force is the maximum lateral force measured by the load cell mounted between the shoulder clevis assembly and the shoulder rib doubler and filtered at a CFC of 600 Hz.

<sup>1</sup> For details of each Channel Frequency Class (CFC) refer to SAE Recommended Practice J211/1 (revision December 2003).

#### **4. Thorax performance criteria**

- 4.1. The maximum thorax rib deflection is the maximum deflection of any (upper, middle or lower) thorax rib, as determined from the voltage output measurements recorded by the deflection sensor mounted between the rib accelerometer mounting bracket and central spine box mounting bracket inside each struck-side thorax rib, and filtered at a CFC of 600 Hz.

#### **5. Abdominal performance criteria**

- 5.1. The maximum abdominal rib deflection is the maximum deflection of any (upper or lower) abdominal rib, as determined from the voltage output measurements recorded by the deflection sensor mounted between the rib accelerometer mounting bracket and central spine box mounting bracket inside each struck-side abdominal rib, and filtered at a CFC of 600 Hz.
- 5.2. The value of the resultant lower spine (T12) acceleration ( $a_R$ ) which is exceeded for 3 milliseconds cumulatively (i.e. across one or more peaks) is calculated from the expression:

$$a_R = \sqrt{a_x^2 + a_y^2 + a_z^2}$$

Where:

$a_x$  = the longitudinal (x-axis) acceleration of the dummy lower spine recorded versus time and filtered at a CFC of 180 Hz;

$a_y$  = the lateral (y-axis) acceleration of the dummy lower spine recorded versus time and filtered at a CFC of 180 Hz; and

$a_z$  = the vertical (z-axis) acceleration of the dummy lower spine recorded versus time and filtered at a CFC of 180 Hz.

#### **6. Pelvis performance criteria**

- 6.1. The peak pubic symphysis force is the maximum force measured by the load cell at the pubic symphysis of the pelvis and filtered at a CFC of 600 Hz.
-