

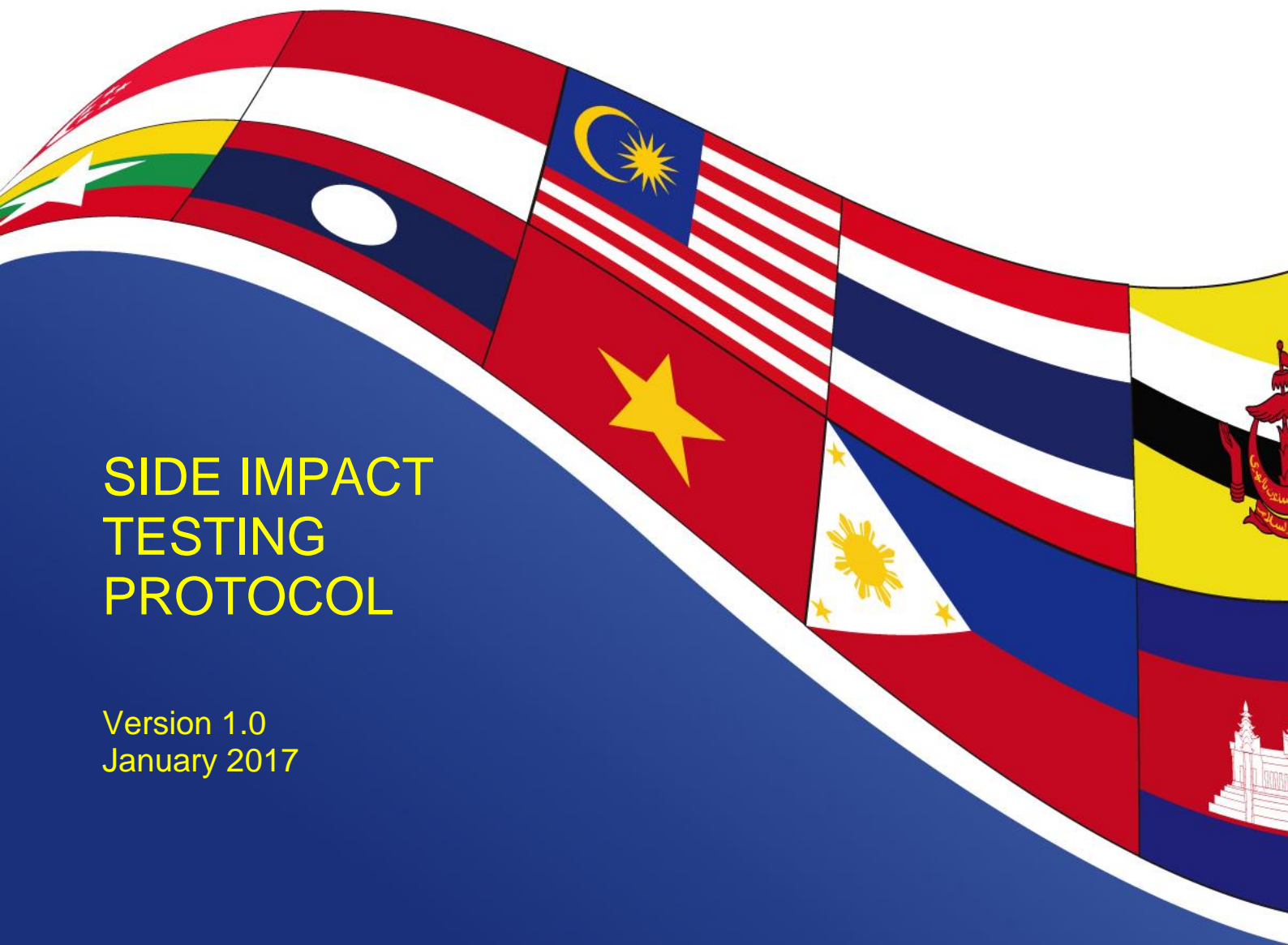

ASEAN
NCAP
www.aseancap.org



SIDE IMPACT TESTING PROTOCOL

Version 1.0
January 2017

SIDE IMPACT TESTING PROTOCOL

Table of Contents

1	<i>VEHICLE PREPARATION</i>	1
1.1	Unladen Kerb Mass	1
1.2	Reference Loads.....	1
1.3	‘R’ Point	2
1.4	Vehicle Preparation.....	2
1.5	Vehicle Markings.....	3
2	<i>DUMMY PREPARATION AND CERTIFICATION</i>	4
2.1	General	4
2.2	Certification	4
2.3	Additions and Modifications to the ES-2 Dummy	4
2.4	Dummy Clothing and Footwear	4
2.5	Dummy Test Condition.....	5
2.6	Post Test Dummy Inspection	6
3	<i>INSTRUMENTATION</i>	7
3.1	Dummy Instrumentation	7
3.2	Vehicle Instrumentation.....	8
3.3	Trolley and Barrier Instrumentation.....	8
4	<i>CAMERA LOCATIONS</i>	9
5	<i>PASSENGER COMPARTMENT ADJUSTMENTS</i>	11
5.1	Determination of and Setting the Fore/aft Position of the Seat.....	12
5.2	Setting the Seat Base Vertical, Tilt and Lumbar Positions.....	13
5.3	Setting the Steering Wheel Horizontal Adjustment	13
5.4	Setting the Steering Wheel Vertical Adjustment	13
5.5	Setting the rear seat (if adjustable)	13
6	<i>DUMMY POSITIONING AND MEASUREMENTS</i>	14
6.1	Determine the H-point of the driver’s seat.....	14
6.2	Dummy Installation.....	15
6.3	Dummy Placement.....	15
6.4	Child Restraint System (CRS) Installation and Child Dummy Placement	17
6.5	Dummy Positioning Measurements	20
7	<i>BARRIER AND TROLLEY</i>	21

7.1	Trolley Preparation	21
7.2	Trolley Markings	21
8	<i>STILL PHOTOGRAPHY</i>	22
9	<i>TEST PARAMETERS</i>	23
9.1	Speed	23
9.2	Post-Impact Braking	23
9.3	Alignment	23
9.4	Door Opening Force	23
9.5	Dummy Removal	24
10	<i>CALCULATION OF INJURY PARAMETERS</i>	25
10.1	Head	26
10.2	Ribs	27
10.3	Abdomen	27
10.4	Pelvis	27
10.5	Pubic Symphysis	27
10.6	Child Dummies	27
 Appendix I		
1	<i>IMPACTOR SPECIFICATIONS</i>	29

NEW CAR ASSESSMENT PROGRAM FOR SOUTHEAST ASIAN COUNTRIES (ASEAN NCAP)

SIDE IMPACT TESTING PROTOCOL

1 VEHICLE PREPARATION

1.1 Unladen Kerb Mass

Note: EC directive 96/27/EC defines the Unladen Mass of the vehicle as the mass with 90% fuel but all other fluids at maximum capacity.

- 1.1.1 The capacity of the fuel tank will be specified in the manufacturer's booklet. This volume will be referred to throughout as the "fuel tank capacity".
- 1.1.2 Syphon most of the fuel from the tank and then run the car until it has run out of fuel.
- 1.1.3 Refill the tank with fuel, water or other ballast to a weight equivalent to 90% of its fuel tank capacity of fuel.
- 1.1.4 Check the oil level and top up to its maximum level if necessary. Similarly, top up the levels of all other fluids to their maximum level if necessary.
- 1.1.5 Ensure that the vehicle has its spare wheel on board along with any tools supplied with the vehicle. Nothing else should be in the car.
- 1.1.6 Ensure that all tyres are inflated according to the manufacturer's instructions for half load.
- 1.1.7 Measure the front and rear axle weights and determine the total weight of the vehicle. The total weight is the 'unladen kerb mass' of the vehicle. Record this mass in the test details.
- 1.1.8 Measure and record the ride heights of the vehicle at all four wheels.

1.2 Reference Loads

- 1.2.1 Place both front seats in their mid-positions, this may not be the same as the final test position. If there is no notch at this position, set the seat in the nearest notch rearward (this will be done more completely in Section 5).
- 1.2.2 Place weights equivalent to an ES-2 test dummy (80 kg) in the front driver's seating position.
- 1.2.3 Place weights in the luggage compartment of the vehicle until the total vehicle mass (sum of front and rear axle masses) is 100 kg more than the unladen kerb mass (from Section 1.1.7). The normal luggage compartment should be used i.e. rear seats should not be folded to increase the luggage capacity. Spread the weights as evenly as possible over the base of the luggage compartment. If the weights cannot be evenly distributed, concentrate weights towards the centre of the compartment.
- 1.2.4 In the child restraints recommended by the manufacturer, place masses equivalent to a 1½ and a 3 year old child dummy on the rear driver seat and passenger seat respectively (11 kg and 15 kg). If the child restraints are not available at this time then default masses of 3 kg should be added to the dummy masses.
- 1.2.5 For the two seater vehicles only, the mass of child dummies and child seats shall not be included in the reference load. For vehicles with limited rear space, child seats and dummies shall be included in the reference load.

- 1.2.6 Roll the vehicle back and forth to ‘settle’ the tyres and suspension with the extra weight on board. Weight the front and rear axle weights of the vehicle. These loads are the “axle reference loads” and the total weight is the “reference mass” of the vehicle.
- 1.2.7 Record the axle reference loads and reference mass in the test details.
- 1.2.8 Measure and record the ride-heights of the vehicle at the point on the wheel arch in the same transverse plane as the wheel centres. Do this for all four wheels.
- 1.2.9 Remove the weights from the luggage compartment and from the front and rear seats.

1.3 ‘R’ Point

To measure vehicle dimensions and to apply markers, a pointer used to measure co-ordinates in three dimensions will be used.

- 1.3.1 The location of the R point relative to some part of the vehicle structure will have been provided by the manufacturer. Determine the position of this point.
- 1.3.2 Mark a point on the driver’s side of the car which has X (longitudinal) co-ordinate not more than 1 mm different to the theoretical R point location.
- 1.3.3 Draw a vertical line through the R-Point and mark it clearly ‘R’.
- 1.3.4 Mark points along the side of the vehicle which have the same X co-ordinates as the ‘R’ point. Continue these points onto the roof of the vehicle. The points should all lie in the same vertical transverse plane as the ‘R’ point.
- 1.3.5 Using a piece of sticky tape in a colour to contrast with the body-colour, join the points with one edge of the tape. Mark clearly on the tape which of its edges aligns with the ‘R’ point. This edge may be used to assess the alignment of the barrier with the ‘R’ point.

1.4 Vehicle Preparation

Care should be taken during vehicle preparation that the ignition is not switched on with the battery or airbag disconnected. This will result in an airbag warning light coming on and the airbag system will need to be reset.

- 1.4.1 Remove the carpeting, spare wheel and any tools or jack from the luggage area. The spare wheel should only be removed if it will not affect the crash performance of the vehicle.
- 1.4.2 Ensure that the vehicle’s battery is connected, if possible in its standard position. Check that the dashboard light for the airbag circuit functions as normal.
- 1.4.3 Fit the on-board data acquisition equipment in the boot of the car. Also fit any associated cables, cabling boxes and power sources.
- 1.4.4 Place weights equivalent to a ES-2 dummy (80 kg) in the front driver’s seat of the car (with the front seats in their mid-positions).
- 1.4.5 In the child restraints recommended by the manufacturer, place masses equivalent to a 1½ and a 3 year old child dummy on the rear driver seat and passenger seat respectively (11 kg and 15 kg). If the child restraints are not available at this time then default masses of 3kg should be added to the dummy masses.
- 1.4.6 Weight the front and rear axle weights of the vehicle. Compare these weights with those determined in Section 1.2.5
- 1.4.7 The total vehicle mass shall be within 1% of the reference mass (Section 1.2.5). Each axle load shall be within the smallest of 5% or 20kg of its respective axle reference load (Section 1.2.5). If the vehicle differs from the requirements given in this paragraph, items may be removed or added to the vehicle which has no influence on its structural crash performance. The level of ballast in the fuel tank (equivalent in mass to 90% capacity of

fuel) may also be adjusted to help achieve the desired axle weights. Any items added to increase the vehicle weight should be securely attached to the car.

- 1.4.8 Repeat Sections 1.4.6 and 1.4.7 until the front and rear axle weights and the total vehicle weight are within the limits set in 1.4.7. Record the final axle weights in the test details.

1.5 Vehicle Markings

- 1.5.1 ASEAN NCAP markings will be attached to the exterior of the vehicle in the following locations; centre of the bonnet and on the front half of the roof of the vehicle. Refer to Figure 1.1. Areas marked with a dotted box are considered acceptable to place ASEAN NCAP markings within.
- 1.5.2 Test house logos may be added to the vehicle provided that they do not detract attention from the ASEAN NCAP markings. Suitable locations for such markings would be the middle of the roof and on the bonnet at the base of the windscreen.

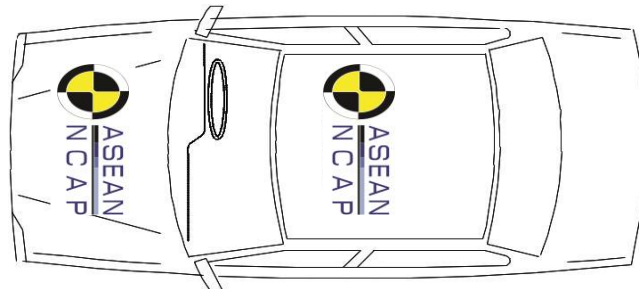

Figure 1.1

2 DUMMY PREPARATION AND CERTIFICATION

2.1 General

- 2.1.1 An ES-2 test dummy shall be used in the front driver's position. It shall conform to the requirements given in document TRANS-WP29-GRSP-2002-11e, which was presented to GRSP on 13th – 17th May 2002 (thirty first session).
- 2.1.2 A Q1½ child dummy, in a suitable Child Restraint System (CRS) (see Section 6.4), shall be used in the rear driver side seating position.
- 2.1.3 A Q3 child dummy, in a suitable CRS (see Section 6.4), shall be used in the rear passenger side seating position.

2.2 Certification

Full details of the ES-2 certification requirements are available in the document mentioned in Section 2.1.1, TRANS-WP29-GRSP-2002-11e, and the procedures followed are set out in the ES-2 User Manual. Details of the certification procedure for P3 and P1½ dummies are available in the user documentation. No manufacturer shall have access to any pre-test information regarding any of the test equipment to be used by ASEAN NCAP, or be permitted to influence its selection in any way.

- 2.2.1 The ES-2 dummy should be re-certified after every THREE impact tests.
- 2.2.2 The Q3 and Q1½ child dummies shall be re-certified after every TEN impact tests (e.g. 5 frontal and 5 side impacts, or any combination of the two test types).
- 2.2.3 If any injury criterion reaches or exceeds its normally accepted limit (e.g. HIC of 1000) then that part should be re-certified.
- 2.2.4 If any part of a dummy is broken in a test then the part shall be replaced with a fully certified component.
- 2.2.5 Copies of the dummy certification certificates will be provided as part of the full report for a test.

2.3 Additions and Modifications to the ES-2 Dummy

- 2.3.1 The ES-2 dummy neck shall be fitted only with neck buffer 80 shore colour blue, part number: E2.BBC. The assembly must meet the certification procedure detailed below.

2.4 Dummy Clothing and Footwear

2.4.1 ES-2

- 2.4.1.1 The dummy will be clothed in an ES-2 rubber 'wet-suit', covering the shoulders, thorax, upper parts of the arms, abdomen and lumbar spine and the upper part of the pelvis. This rubber suit will act as a nominal 'skin' for the dummy torso.
- 2.4.1.2 The dummy will be clothed with formfitting, calf-length, cotton stretch pants and shoes.

2.4.2 Child Dummies

- 2.4.2.1 Each child dummy shall wear their appropriate suits, Q3 part number 020-8000, Q1½ part number 048-8000.

2.5 Dummy Test Condition

2.5.1 Dummy Temperature

2.5.1.1 The dummy shall have a stabilised temperature in the range of 18°C to 26°C.

2.5.1.2 A stabilised temperature shall be obtained by soaking the dummy in temperatures that are within the range specified above for at least 5 hours prior to the test.

2.5.1.3 Measure the temperature of the dummy using a recording electronic thermometer placed inside the dummy's flesh. The temperature should be recorded at intervals not exceeding 10 minutes.

2.5.1.4 A printout of the temperature readings is to be supplied as part of the standard output of the test.

2.5.2 Dummy Joints

2.5.2.1 Stabilise the dummy temperature by soaking in the required temperature range for at least 5 hours.

2.5.2.2 Set the torque on the shoulder screws to obtain a 1-2g holding force of the arm on its pivot.

2.5.2.3 For adjustable joints in the legs, the tensioning screw or bolt which acts on the constant friction surfaces should be adjusted until the joint can just hold the adjoining limb in the horizontal. When a small downward force is applied and then removed, the limb should continue to fall.

2.5.2.4 The dummy joint stiffness should be set as close as possible to the time of the test and, in any case, not more than 24 hours before the test.

2.5.2.5 Maintain the dummy temperature within the range 18°C to 26°C between the time of setting the limbs and up to a maximum of 10 minutes before the time of the test.

2.5.3 Dummy Painting and Marking

2.5.3.1 The dummies should have masking tape placed on the areas to be painted using the size table below. The tape should be completely covered with the following coloured paints. The paints should be applied close to the time of the test to ensure that the paint will still be wet on impact.

ES-2

Head (Paint tape outline only)	Red
Shoulder/Arm	Blue
Top Rib	Red
Mid Rib	Yellow
Bottom Rib	Green
Abdomen	Red
Pelvis	Orange

Child dummies

Top of Head	Blue
Head-band thirds (colours from left to right)	Red, Yellow, Green

NOTE: The tape should be completely covered with the coloured paints specified, with the exception of the ES-2 Head which should have only the outer edge of the tape painted. Adhesive target markers should be attached to the top/rear of the child dummy's head in order to aid the assessment of the child head containment.

Tape Sizes:

ES-2

Head	=	100 mm square, centreline of head with lower edge at C of G.
Shoulder/Arm	=	25 mm x 150 mm, starting at the bottom edge of shoulder fixing hole.
Ribs	=	150 mm strip, starting at the rearmost accessible point at seat back.
Abdomen	=	50 x 50 mm square
Pelvis	=	50 mm x 100 m, centred on hip joint point

Child Dummies

Top of Head	=	50 x 50mm square
Headbands	=	25mm wide, widest circumference remaining at eyebrow level at front, extending to the head C of G at each side.

2.6 Post Test Dummy Inspection

- 2.6.1 The dummy should be visually inspected immediately after the test. Any lacerations of the skin or breakages of the dummy should be noted in the test details. The dummy may have to be re-certified in this case. Refer to Section 2.2.

3 INSTRUMENTATION

All instrumentation shall be calibrated before the test programme. The Channel Amplitude Class (CAC) for each transducer shall be chosen to cover the Minimum Amplitude listed in the table. In order to retain sensitivity, CACs which are orders of magnitude greater than the Minimum Amplitude should not be used. A transducer shall be re-calibrated if it reaches its CAC during any test. All instrumentation shall be re-calibrated after one year, regardless of the number of tests for which it has been used. A list of instrumentation along with calibration dates should be supplied as part of the standard results of the test. The transducers are mounted according to procedures laid out in SAE J211. The sign convention used for configuring the transducers is stated in SAE J211 (1995).

3.1 Dummy Instrumentation

The ES-2 dummy to be used shall be instrumented to record the channels listed below.

ES-2

Location	Parameter	Minimum Amplitude	No of channels
Head	Accelerations, $A_x A_y A_z$	250g	3
Shoulder	Forces, $F_x F_y F_z$	8kN	3
Thorax T1	Accelerations, $A_x A_y A_z$	200g	3
Thorax T12	Accelerations, A_y	200g	1
Ribs – Upper Middle Lower	Accelerations, A_y	700g	3
	Deflection, D_{rib}	90mm	3
Abdomen – Front Middle Rear	Forces, F_y	5kN	3
Backplate	Forces, $F_x F_y$	5kN	4
	Moments, $M_y M_z$	200Nm	
T12	Forces, $F_x F_y$	5kN	4
	Moments, $M_x M_y$	300Nm	
Pelvis	Accelerations, $A_x A_y A_z$	150g	3
Public Symphysis	Force, F_y	20kN	1
Femurs (L&R)	Forces, $F_x F_y F_z$	22kN	6
	Moments, $M_x M_y M_z$	350Nm	6
Total Channels per Dummy			43
1 x ES-2			43

Q3

Location	Parameter	Minimum Amplitude	No of channels
Head	Accelerations, $A_x A_y A_z$	150g	3
Chest	Accelerations, $A_x A_y A_z$	150g	3
Total Channels per Dummy			6

Q1½

Location	Parameter	Minimum Amplitude	No of channels
Head	Accelerations, $A_x A_y A_z$	150g	3
Chest	Accelerations, $A_x A_y A_z$	150g	3
Total Channels per Dummy			6

3.2 Vehicle Instrumentation

- 3.2.1 The vehicle is to be fitted with an accelerometer on the unstruck B-post. The accelerometer is to be fitted in the lateral direction (A_y).
- 3.2.2 Remove carpet and the necessary interior trim to gain access to the sill directly below the B-post.
- 3.2.3 Securely attach a mounting plate for the accelerometer horizontally on to the sill.
- 3.2.4 Fix the accelerometer to the mounting plate. Ensure the accelerometer is horizontal to a tolerance of ± 5 degrees.

VEHICLE

Location	Parameter	Minimum Amplitude	No of channels
B-Post (unstruck)	Accelerations, A_y	150g	1
Total Channels per Vehicle			1

3.3 Trolley and Barrier Instrumentation

- 3.3.1 The trolley is to be fitted with an accelerometer at its Centre of Gravity. The accelerometer is to be fitted in the fore/aft direction (A_x). (See Section 7)

TROLLEY

Location	Parameter	Minimum Amplitude	No of channels
Trolley C of G	Accelerations, A_y	150g	1
Total Channels per Trolley			1

TOTAL CHANNELS

1x Driver ES-2	43
1x Q3	6
1x Q1½	6
1x Vehicle	1
1x Trolley	1
TOTAL	57

4 CAMERA LOCATIONS

Set up high speed film cameras according to the following diagrams

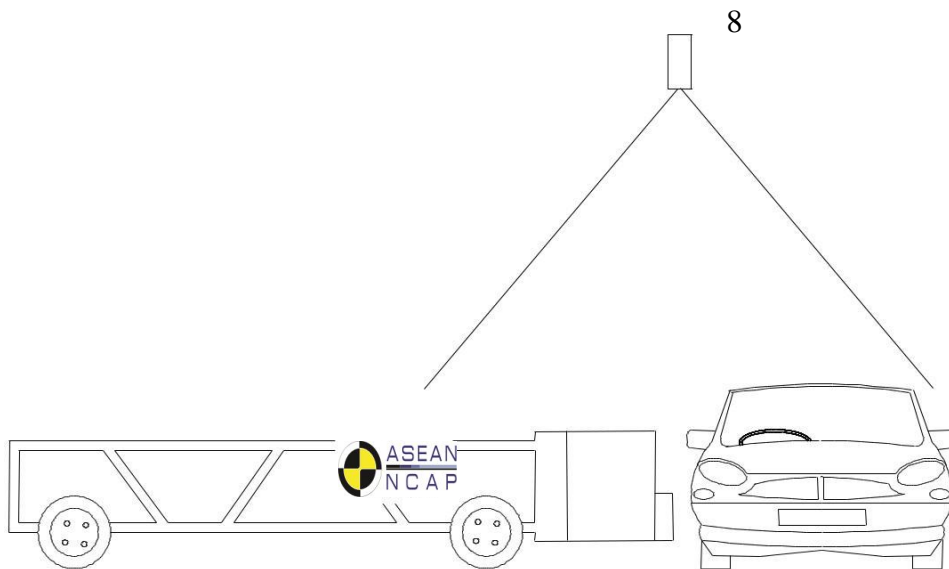
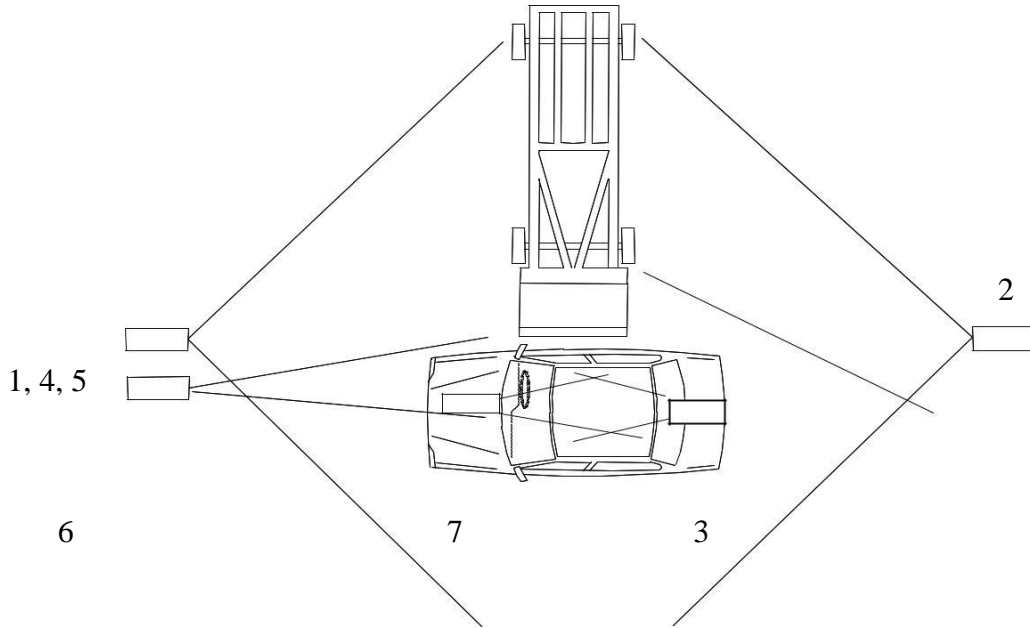

Camera No.	Camera Type	Shot Content
1	>/= 500 fps high speed	Front view of vehicle and trolley (wide)
2	>/= 500 fps high speed	Rear view of vehicle and trolley (wide)
3	>/= 500 fps high speed	Child head containment
4	>/= 500 fps stills camera	Front view of vehicle and trolley (wide)
5	>/= 500 fps stills camera	Backup for 4 (optional)
6	>/= 500 fps high speed	Front view of driver and impact point (tight)
7	>/= 500 fps high speed	Child head containment, onboard
8	>/= 500 fps high speed	Plan view of car and trolley (tight)

- 4.1** The ASEAN NCAP High Speed Digital Film Specifications are contained in a separate document.
- 4.2** Lens sizes should be chosen appropriately in order to achieve the required shot content/intention. In order to prevent view distortion, a minimum lens size of 9mm is applicable. Please note for view number 7 the passenger side headrest should be removed if possible.
- 4.3** For forward facing CRS, cameras 3 and 7 shall face toward the rear of the vehicle to capture head containment. For rearward facing CRS, the camera should face toward the front of the vehicle to capture head containment. The positioning of onboard cameras will be dependent upon the body type and size of test vehicle.
- 4.4** When attaching onboard cameras, the vehicle manufacturer should be consulted to ensure that no damage is caused to the vehicle that would influence the impact performance or interfere with any airbags during deployment. Where additional equipment is added, the mass shall be offset when achieving the final test weight.

5 PASSENGER COMPARTMENT ADJUSTMENTS

Adjustment	Required Setting	Notes	Methods
Seat Fore/Aft	Mid position as defined in 5.1	Set to first notch rearwards of mid position if not lockable at mid position	See Section 5.1
Seat Belt Tilt	Manufacturer's design position	Permissible Up to mid position	See Section 5.2
Seat Height	Same height as non-adjustable version of front seat	If only adjustable seats available, set to mid-position	
Seat Back Angle (as defined by torso angle)	Manufacturer's design position	Otherwise 25° to Vertical	See Section 6.1
Seat Lumbar Support	Manufacturer's design position	Otherwise fully retracted	
Front Head Restraint Height & Tilt	Mid locking position	As whiplash test position	See Section 7.2 Whiplash testing protocol
Steering wheel - vertical	Mid position		See Section 5.4
Steering wheel - horizontal	Mid position		See Section 5.3
Rear Seat Fore/Aft	Mid position	Vehicle manufacturer to supply details of seat position contained in handbook when no handbook is available at the time of test	See Section 5.5.1
Rear Seat Back Angle	Manufacturer's design position	Otherwise 25° to Vertical	See Section 6.1
Rear Seat Facing	Forward		See Section 5.5.1
Rear Head Restraint Height	As recommended in vehicle handbook	Where no details are provided in the handbook, set to mid or next lowest position. Must not interfere with CRS installation	
Rear Head Restraint Tilt	Mid locking position (where adjustable)	As whiplash test position	See Section 7.2 Whiplash testing protocol
Arm-rests (Front seats)	Lowered position	May be left up if dummy positioning does not allow lowering	
Arm-rests (Rear seats)	Stowed position		

Glazing	Front – Raised Rear - Raised		
Gear change lever	In the neutral position		
Parking Brake	Disengaged		
Pedals	Normal position of rest		
Doors	Closed, not locked		
Roof	Raised	Where applicable	
Sun Visors	Stowed position		
Rear view mirror	Normal position of use		
Seat belt anchorage (where adjustable)	Initially, manufacturer's 50 th percentile design position	If no design position then set to mid position, or nearest notch upwards	

Adjustment not listed will be set to mid-positions or nearest position rearward, lower or outboard. If both an adjustable and non-adjustable seat is fitted, the adjustable seat should be set to the same position as the non-adjustable version.

5.1 Determination of and Setting the Fore/aft Position of the Seat

- 5.1.1 The manufacturer's seat fore/aft position which corresponds to the 95th percentile male seating position will have been provided.
- 5.1.2 Place a mark on the moving part of seat runner close to the unmoving seat guide.
- 5.1.3 Move the seat to its most forward position of travel.
- 5.1.4 Mark the unmoving seat guide in line with the mark on the seat runner. This corresponds to the seat in its most forward position.
- 5.1.5 Move the seat to the position of its travel provided for the 95th percentile male.
- 5.1.6 Mark the unmoving seat guide in line with the mark on the seat runner. This corresponds to the 95th percentile male's seating position.
- 5.1.7 Measure the distance between the forwards and rearwards marks. Place a third mark on the seat guide mid-way between the forwards and rearwards marks.
- 5.1.8 Move the seat so that the mark on the seat runner aligns with the mark on the seat guide.
- 5.1.9 Lock the seat at this position. Ensure that the seat is fully latched in its runners on both sides of the seat. The seat is now defined as being at its 'mid seating position'. The vehicle will be tested with the seat in this position.
- 5.1.10 If the seat will not lock in this position, move the seat to the first locking position that is rear of the mid seating position. The vehicle will be tested with the seat in this position.

5.2 Setting the Seat Base Vertical, Tilt and Lumbar Positions

- 5.2.1 If the seat is adjustable for the height, the manufacturer will be asked whether the vehicle is made with non-adjustable seats for driver or passenger. If this is the case, the manufacturer will be asked what the height of the H-point is for the non-adjustable version.
- 5.2.2 Using the procedure described more fully in Section 6.1, sit the H-point manikin in the seat.
- 5.2.3 Adjust the height of the seat until the H-point of the manikin is at the same height as that given by the manufacturer's information.
- 5.2.4 If the vehicle is not available with non-adjustable seat height, set the seat to its middle position.
- 5.2.5 If the seat base is adjustable for tilt it may be set to any angle from the flattest to its mid position according to the manufacturer's preference. The same seat tilt setting must be used for frontal and side impact.
- 5.2.6 Set Lumbar Setting. If the seat back is adjustable for lumbar support it should be set to the fully retracted position, unless the manufacturer specifies otherwise or the dummy prevents this.

The setting for the passenger seat should be as near as possible to being the same as that of the driver's seat.

5.3 Setting the Steering Wheel Horizontal Adjustment

- 5.3.1 Choose a part of the facia that is adjacent to the steering column and can be used as a reference.
- 5.3.2 Move the steering wheel to the most forward position of its travel.
- 5.3.3 Mark the steering column in line with unmoving part of the facia. This corresponds to the most forward travel of the steering wheel.
- 5.3.4 Move the steering wheel to the most rearwards position of its travel.
- 5.3.5 Mark the steering column in line with an unmoving part of the facia. This corresponds to the most rearwards travel of the steering wheel.
- 5.3.6 Measure the distance between the forwards and rearwards marks on the steering column. Place a third mark on the steering column mid-way between the forwards and rearwards marks. This corresponds to the centre of travel of the steering wheel.
- 5.3.7 Move the steering wheel so that the mark on the steering column aligns with the facia.
- 5.3.8 Lock the steering column at this position. The steering wheel is now in its mid-position of travel. The vehicle will be tested with the steering wheel in this position.

5.4 Setting the Steering Wheel Vertical Adjustment

- 5.4.1 A method that is in principle the same as Section 5.3 should be used to find and set the steering wheel vertical adjustment to the mid position. It is unlikely that the same part of the facia used during the setting procedures for the horizontal adjustments could be used for the vertical adjustments. Care should be taken to avoid unintentional adjustment of the horizontal setting during the vertical adjustments procedure.

5.5 Setting the rear seat (if adjustable)

- 5.5.1 If the vehicle rear seat position is adjustable put it in the same fore/aft position as that used in the frontal with the same seat back angle.

6 DUMMY POSITIONING AND MEASUREMENTS

The following chapter deals with all aspects of seating the dummy in the vehicle to be tested. A general timetable of the complete procedure is set out below:-

Timetable

	<i>When this is done</i>
1 Determine the H-point of the driver's seat	Before test day
2 Dummy installation (on boards)	Before test day
3 Dummy placement	Test day
4 Dummy positioning	Test day
5 Dummy positioning measurements	Test day – after vehicle has been positioned for test

6.1 Determine the H-point of the driver's seat

The device to be used is the H-point machine as described in SAE J826

If the seat is new and has never been sat upon, a person of mass $75 \pm 10\text{kg}$ should sit on the seat for 1 minute twice to flex the cushions.

The seat shall have been at room temperature and not been loaded for at least 1 hour previous to any installation of the machine.

6.1.1 Set the seat back so that the torso of the dummy is as close as possible to the manufacturer's recommendations for normal use. In absence of such recommendations, an angle of 25 degrees towards the rear from vertical will be used.

6.1.1.1 The driver and passenger seatback angle and seat base shall be set to the same position.

6.1.1.2 Where one seat is height adjustable and the other is fixed, the relative angle between the seat back and the ground should be the same for both seats.

6.1.1.3 Where both seats are adjustable, the manufacturer is asked to supply recommended settings. These should not differ from the nominal settings by more than a reasonable amount. In any of the above situations, the manufacturer may provide convincing information that the seat adjustments should be different from that specified here. If so the fully supported request to vary the set up should be made to the Secretariat.

- 6.1.2 Place a piece of muslin cloth on the seat. Tuck the edge of the cloth into the seat pan/back join, but allow plenty of slack.
- 6.1.3 Place the seat and back assembly of the H-point machine on the seat at the centre line of the seat.
- 6.1.4 Set the thigh and lower leg segment to 401 and 414 mm respectively.
- 6.1.5 Attach lower legs to machine, ensuring that the transverse member of the T-bar is parallel to the ground.
- 6.1.6 Place right foot on undepressed accelerator pedal, with the heel as far forwards as allowable. The distance from the centre line of the machine should be noted.
- 6.1.7 Place left foot at equal distance from centre line of machine as the right leg is from centre line. Place foot flat on footwell.
- 6.1.8 Apply lower leg and thigh weights.
- 6.1.9 Tilt the back pan forwards to the end stop and draw the machine away from the seat back.
- 6.1.10 Allow the machine to slide back until it is stopped by contacting the seat back.
- 6.1.11 Apply the 10 kg load twice to the back and pan assembly positioned at the intersection of the hip angle intersection to a point just above the thigh bar housing.
- 6.1.12 Return the machine back to the seat back.
- 6.1.13 Install the right and left buttock weights.
- 6.1.14 Apply the torso weights alternately left and right.
- 6.1.15 Tilt the machine back forwards to the end stop and rock the pan by 5 degrees either side of the vertical. The feet are NOT to be restrained during the rocking. After rocking the T-bar should be parallel to the ground.
- 6.1.16 Reposition the feet by lifting the leg and then lowering the leg so that the heel contacts the floor and the sole lies on the undepressed accelerator.
- 6.1.17 Return the machine back to the seat back.
- 6.1.18 Check the lateral spirit level and if necessary apply a lateral force to the top of the machine back, sufficient to level the seat pan of the machine.
- 6.1.19 Adjust the seat back angle to the angle determined in 6.1.1, measured using the spirit level and torso angle gauge of the H-point machine. Ensure that the torso remains in contact with the seat back at all times. Ensure that the machine pan remains level at all times.
- 6.1.20 Measure and record in the test details the position of the H-point relative to some easily identifiable part of the vehicle structure.

6.2 Dummy Installation

It is the intention that the dummy should not be left to sit directly on the seat for more than 2 hours prior to the test. It is acceptable for the dummy to be left in the vehicle for a longer period, provided that the dummy is not left in overnight or for a similarly lengthy period.

If it is known that the dummy will be in the vehicle for a time longer than 2 hours, then the dummy should be sat on plywood boards placed over the seat. This should eliminate unrealistic compression of the seat.

6.3 Dummy Placement

If the vehicles only have two side doors, it may be necessary to fit the child restraint system and child dummies (Section 6.4) before setting up the ES-2 dummy in the front seat.

6.3.1 H-point

Note that the H-point of the ES-2 dummy is situated 21 mm forward of that of the H-point determined by the H-point manikin (Section 6.1). The H-point of the manikin is indicated by 'Hm' on the H-point back plate of the dummy.

6.3.1.1 Position the dummy in the seat, with its back against the seat and its centreline coinciding with the seat centreline.

6.3.1.2 Manoeuvre the dummy until its "Hm" position is in a circle with a radius of 10 mm round the H-point of the H-point Manikin as determined in Section 6.1.

6.3.2 Alignment

Visually check that the dummy sits square and level in the seat before taking any measurements of the H-point position.

6.3.3 Legs and Feet

6.3.3.1 Position the left foot perpendicular to the lower leg with its heel on the floorpan in a transverse line with the heel of the right foot.

6.3.3.2 Carefully position the dummy's right foot on the undepressed accelerator pedal with the heel resting as far forward as possible on the floorpan.

6.3.3.3 Measure the separation of the inside surfaces of the dummy's knees and adjust until they are 150 ± 10 mm apart from each other.

6.3.3.4 If possible within these constraints, place the thighs of the dummy on the seat cushion.

6.3.3.5 Check again the position of the H-point, the levelness of the pelvis and the squareness of the dummy in the seat. If everything is in position, set the arms.

6.3.4 Arms

The arms of the ES-2 dummy have click-stops corresponding to fixed angles between the torso reference line and the arms.

6.3.4.1 Move both arms of the dummy until they have clicked at those positions corresponding to 40° angle between the arms and the torso reference line.

6.3.5 Seat belt

- 6.3.5.1 Where possible, initially position the upper seat belt anchorage in the manufacturers 50th percentile design position. If no design position is provided, set the adjustable upper seat belt anchorage to the mid-position or nearest notch upward.
- 6.3.5.2 Carefully place the seat belt across the dummy and lock as normal.
- 6.3.5.3 Remove the slack from the lap section of the webbing until it is resting gently around the pelvis of the dummy. Only minimal force should be applied to the webbing when removing the slack. The route of the lap belt should be as natural as possible.
- 6.3.5.4 Place one finger behind the diagonal section of the webbing at the height of the dummy sternum. Pull the webbing away from the chest horizontally forward and allow it to retract in the direction of the D-loop using only the force provided by the retractor mechanism. Repeat this step three times, only.
- 6.3.5.5 After following the above steps, the seatbelt should lie in a natural position across the dummy sternum and shoulder clavicle. Where this is not the case, for example the belt is close to or in contact with the neck or the belt is above the shoulder rotation adjustments screw, and the upper belt anchorage is adjustable the anchorage should be lowered and step 6.3.5.3 and 6.3.5.4 repeated.
- 6.3.5.6 The upper anchorage should be lowered by a sufficient amount to ensure a natural belt position following the repetition of step 6.3.5.3 and 6.3.5.4 repeated. This may require multiple attempts.
- 6.3.5.7 Once the belt is positioned the location of the belt should be marked across the dummy chest to ensure that no further adjustments are made. Mark also the belt at the level of the D-loop to be sure that the initial tension is maintained during test preparation.
- 6.3.5.8 Measure the vertical distance between the dummy nose and the diagonal webbing.
- 6.3.5.9 Measure the horizontal distance between the diagonal webbing and the door/window.

6.4 Child Restraint System (CRS) Installation and Child Dummy Placement

Two CRS's are to be fitted in the rear seat, one suitable for a 3 year old child, the other for an 18 month old infant. Each will be the system recommended by the manufacturer for that size of the child. The type of the system to be fitted will be determined from the manufacturer. There must be sufficient space between the vehicle interior and CRS to allow for proper installation of the restraint without the need for excessive force. The restraint must not be prevented from sitting in its 'normal' orientation, for example the vehicle interior trim must not cause any obstruction. The dummies must also be allowed to rest in a 'normal' position.

- 6.4.1 Read the relevant section of the vehicle handbook and the instructions provided with the child restraint. This is to identify any special features of either the vehicle or the child restraint that are intended to improve performance or may influence installation. Instructions on tightening of the adult seat belt around the child restraint should be noted, but the installation itself should follow the procedure below.
- 6.4.2 Calibrate the seat belt tension load cells to be used in the CRS installation process at the required load reading i.e. 50N for lap and diagonal installations and 75N for lap belt applications directly before beginning the installation procedure.
- 6.4.3 Ensure that the seat and belt anchorage positions are as defined in Section 5.5. In the case of an adult seat belt that is capable of being switched from an emergency locking retractor (ELR) to an automatic locking retractor (ALR) follow clear advice, obvious to the user, about how the ALR feature should be used on any labels associated with the seat belt (information given in the handbook will be ignored as reading of the handbook cannot be assumed for all users).

6.4.4 *For Integral Harness Systems*

6.4.4.1 Install the child restraint and place the dummy within it. Place the 2.5 cm thick and 6 cm wide flexible spacer between the back of the manikin and the back of the child restraint. The lower end of the spacer should be at the height of the manikin's hip joint. Adjust the harness restraining the child in accordance with the manufacturer's instructions, but to a tension of 250 +/-50N above the frictional adjuster force. The angle of pull on the webbing should be as indicated in the fitting instructions.

6.4.4.2 Release the harness buckle, remove the spacer, refasten the harness and push the dummy towards the seat back. Arrange the slack within the integral harness so that it is evenly distributed. Make sure the dummy head is upright, and the legs are parallel. Raise the dummy feet and allow them to fall lightly into a stable resting position. Place the dummy's hands so that they are resting on the top of the thighs and tape them lightly in position using a weak paper tape.

6.4.4.3 In the case of a rearward facing restraint, use weak paper tape to locate the dummy head relative to the back of the child restraint. The intention is to prevent dummy displacement under acceleration during the vehicle run-up to the barrier. The tape should be weak enough to break on impact of the vehicle with the barrier.

6.4.5 *For Integral Harness Systems Installed With a 3 Point Seat Belt, With No Lock Off or Lock Off Design That Can Be Released To Give No Friction During Installation*

6.4.5.1 Engage the adult seat belt buckle, fit one load cell outboard on the lap section of the adult belt and one on the free webbing of the diagonal section between the child restraint and the pillar loop. Establish a tension of 50N +/- 5N in both lap and diagonal sections of the adult belt webbing. Apply lock-off devices if available. If the design of the CRS is such that tensioned is maintained within the lap and diagonal sections of webbing, remove the load cell on the free section of diagonal webbing. However, if removal of the diagonal belt load cell changes the installation tension of the belt, leave the load cell in place. Disconnect any electrical leads and stow them ready for impact.

6.4.5.2 Draw all the remaining webbing off the inertia reel of the adult seat belt and allow it to retract slowly under the influence of its own retraction mechanism. If it is the intention for the system not to be activated for the test then draw all the webbing from the reel and allow it to fully retract, prior to the installation of the child seats. Do not fully draw the webbing from the reel after this procedure has been completed.

6.4.6 *For Integral Harness System Installed With a 3 Point Seat Belt, With a Lock-Off Design That Cannot Be Released To Give No Friction During Installation*

6.4.6.1 Place the diagonal belt load cell between the lock-off and the buckle tongue slot and leave it in position during the test. All other aspects of the installation are as per 6.4.5.

6.4.7 *For Booster Seats In Which The Adult Belt Restrains The Child And In Which There Is A Fixed Position Lock-Off*

6.4.7.1 Place the dummy in the seat with the spacer in the position. Locate the diagonal load cell between the lock-off and the buckle tongue slot, in a position where it will not interfere with the dummy's arm movement. Locate the lap section load cell on the outboard adult belt webbing. Establish a load of 50N +/-5N in both sections of the webbing. Leave the load cells in position if their removal would alter the set-up tensions. Release the buckle, remove the spacer and refasten the buckle. Set the dummy back in position as described above in Section 6.4.4 and check the webbing spooled on the inertia reel of the adult belt as per Section 6.4.5.2.

6.4.8 *For Booster Seats In Which The Position Of The Lock-Off/Shoulder Belt Guide Is Adjustable*

6.4.8.1 Optimize the position of the lock-off/shoulder belt guide before beginning the installation process. For those systems in which the adult belt is used to restrain the child directly, insert the spacer and continue the installation as described in 6.4.7. If the adult belt is used to restrain the child rather than the child itself install the load cells as described above. After installation to the specified tensions operate any device that is specifically designed to increase adult seat belt tension by use of a lever or cam type system or their equivalent. The intention is to correctly credit special design features aimed at achieving improved installation.

6.4.9 *For Child Restraints Using An Impact Shield to Restrain The Child*

6.4.9.1 Install the dummy with the spacer and position the shield. Put load cells on lap and diagonal sections of the seat belt. Establish a load of 50N +/-5N in both sections of the webbing and, whilst manually clamping the webbing at the belt guides on the impact shield, release the buckle and rotate the shield forward on the buckle side the minimum amount necessary to allow removal of the spacer. Refasten the buckle, check that the shield is positioned centrally, push the dummy back into the seat and continue with remaining aspects of dummy positioning procedure described in Sections 6.4.4.2 and 6.4.5.2. It will probably be necessary to rest the dummy arms on the shield rather than the thighs as has been suggested for other restraint types.

6.4.9.2 For seats installed with a static lap belt use one load cell on the non buckle side of the adult belt and establish a tension of 75N +/-5N equalised throughout the lap belt. Leave the load cell in place if its removal would alter the set-up tension.

6.4.9.3 The time between the child seat installation and impact should be subject to the same limits that are applied to adult dummies and should be kept as short as possible.

6.4.10 *For "ISOFIX" type seats*

The installation protocol for these seats is under development. If any manufacturers request the use of this type of seat the ASEAN NCAP Secretariat must be contacted for installation instructions. Where a tensioning/ratchet device is provided to secure the child restraint against the rear seats and/or floor etc, a force not exceeding 100N shall be applied in the direction of the tensioning system's movement. Where a top tether is present it should be attached to the anchorage, a maximum force of 50N ± 5N should be applied to the webbing from a position where the user would be expected to install the tether. The angle of pull on the webbing should be as indicated in the fitting instructions. Note: the 50N load is applied directly to the free end of tether, and intentionally does not take account of the internal frictional characteristic of the adjuster.

6.4.11 For reclining child restraint systems

To set the seat angle firstly check the seat itself and instruction manual for recommendations accompanying the seat. If no information is provided consult the manufacturer. If the manufacturer makes no recommendation set to its mid position.

6.5 Dummy Positioning Measurements

The following measurements are to be recorded prior to the test after the dummy setting and positioning procedures have been carried out.

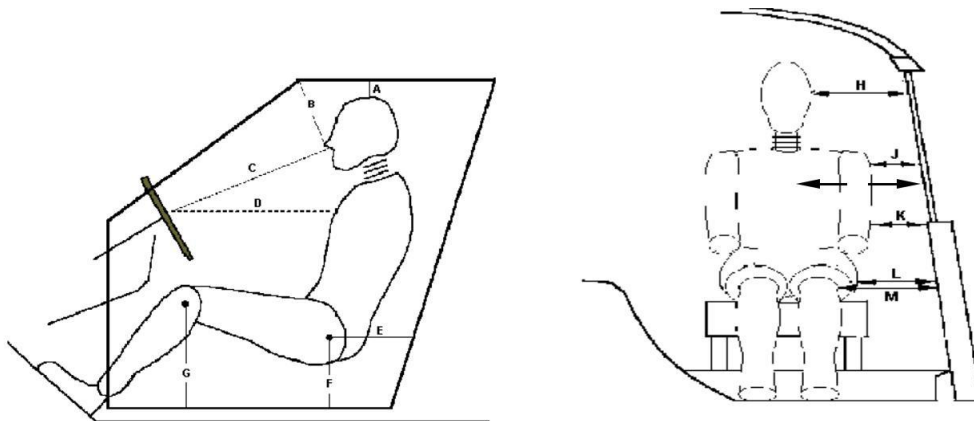

Driver measurements	
A	Head/roof panel
B	Nose point/windscreen joint
C	Nose point/centre of the steering
D*	Thorax strap/centre of the steering wheel
E	Hip-joint point/inside opening of the door (horizontal)
F	Hip-joint point/inside opening of the door (vertical)
G	Knee/floor covering (vertical)
H	Head/side window pane (or padding)
J	Shoulder/window pane (or padding)
K	Elbow/door (or padding)
L	Pelvis/door (or padding)
M	Knee/door (or padding)
N	Belt webbing to door (horizontally)

*Horizontal distance from steering wheel centre

7 BARRIER AND TROLLEY

The trolley will be fitted with a deformable barrier face and ventilation frame conforming to the specifications of Amendment 3, July 2003, Regulation ECE R95 (lateral collision protection). See also Appendix I.

7.1 Trolley Preparation

- 7.1.1 A trolley should be used which has a wheelbase of $3000 \pm 10\text{mm}$ and a track at the front and at the rear of $1500 \pm 10\text{mm}$.
- 7.1.2 The trolley may be fitted with an emergency abort system. This is optional, the test facility may elect to test without an abort system.
- 7.1.3 Inflate all tyres of the trolley to the same pressure.
- 7.1.4 Fix the deformable barrier to the front of the trolley such that its bottom edge is at a height of $300\text{mm} \pm 5\text{mm}$ from the ground.
- 7.1.5 Mark a line along the vertical centreline of the barrier which may be used to check the alignment of the barrier with the R point of the test vehicle.
- 7.1.6 Measure the wheelbase of the trolley, left and right.
- 7.1.7 Determine the average wheelbase from Section 7.1.6 and record in the test details.
- 7.1.8 Record in the test details the track of the trolley at the front and at the rear.
- 7.1.9 Measure the weights at all four wheels and record in the test details. The total weight of the trolley should be **$950 \pm 20\text{kg}$** .
- 7.1.10 Calculate the fore/aft position of the centre of gravity from:
$$x = W_{\text{rear}} \cdot \text{Wheelbase} / (W_{\text{rear}} + W_{\text{front}})$$
where x is the distance of the centre of gravity from the front axle, W_{rear} and W_{front} are the rear and front axle weights from Section 7.1.9 and Wheelbase is the average determined in Section 7.1.7.
The fore/aft centre of gravity should be $1000 \pm 10\text{mm}$ from the centre of the front axle.
- 7.1.11 Record the position of the centre of gravity in the test details.
- 7.1.12 Ensure the weight distribution is as even as possible left to right.
- 7.1.13 Record in the test details the final weights measured at each of the wheels.

7.2 Trolley Markings

- 7.2.1 ASEAN NCAP markings will be stuck to the front of the trolley on both sides.
- 7.2.2 Test house logos may be added to the trolley provided that they do not detract attention from the ASEAN NCAP markings.

8 STILL PHOTOGRAPHY

The following photograph will be taken pre and post-test unless otherwise indicated. Pre-test photographs will be taken with the dummies in their final positions.

<u>No.</u>	<u>View</u>
1	Front view of barrier
2	Side view of barrier
3	Side view of barrier at 45 degrees to front
4	Side view of barrier with vehicle, from front of vehicle
5	Car RHS, with camera centred on B-post waist, showing full car
6	Car RHS, with camera centred on B-post waist, showing the rear passenger compartment
7	Car RHS, with camera aimed at waist height, showing driver's compartment
8	Car RHS at 45 degrees to rear
9	Car RHS at 45 degrees to front
10	Front view of car
11	Car LHS, with camera centred on B-Post waist, showing full car
12	Car LHS, with camera centred on B-Post waist, showing the rear passenger compartment
13	*To show position of all door latches and/or open doors
14	Driver & seat through open driver's door to show driver compartment and position of seat relative to the sill
15	To show area immediately in front of driver
16	To show child dummies and restraints through LHS rear door
17	To show child dummies and restraints through RHS rear door
18	*Car and barrier at rest at 45 degrees to front of car
19	*Car and barrier at rest at 45 degrees to rear of car

*Post-test only

After Dummy Removal

20 *View through LHS front door of driver's door & paint marks from dummy ribs

Note: The above photos are for a RHD car, for a LHD car camera locations will switch sides

9 TEST PARAMETERS

An on-board data acquisition unit will be used. This equipment will be triggered by a contact plate at the point of first contact ($t=0$) and will be record digital information at a sample rate of 20kHz (alternatively a sample rate of 10kHz may be used). The equipment conforms to SAE J211 (1995).

BEFORE THE TEST, ENSURE THAT THE LIVE BATTERY IS CONNECTED, A SINGLE KEY IS IN THE IGNITION, THE IGNITION IS ON AND THAT THE AIRBAG LIGHT ON THE DASHBOARD ILLUMINATES AS NORMAL (WHERE FITTED)

If the vehicle is fitted with a brake pedal retraction mechanism which requires a vacuum present in the brake system, the engine may be ran for a predetermined time, specified by the manufacturer.

9.1 Speed

9.1.1 Measure the speed of the trolley as near as possible to the point of impact.

9.1.2 Record the actual test speed in the test details.

TARGET SPEED = 50km/h \pm 1km/h

9.2 Post-Impact Braking

A method must be employed to eliminate secondary impacts between the barrier and the car. This may be an emergency braking system on the trolley or other method but should be activated only **after the first impact is complete**. DO NOT start the braking *at* point of initial impact or the trolley will be decelerating during the test.

9.3 Alignment

9.3.1 With the vehicle offered up against the barrier, tape a small rivet at the centreline of the deformable barrier as close as possible to the point of first contact.

9.3.2 This pin should align with the vertical 'R' point line previously marked on the car (Section 1.4)

9.3.3 After the test, if the mark made by the pin is not within the tolerance squared detailed below, film analysis will be used to try to access the alignment. Both the horizontal and vertical alignments shall be noted in the test report.

TARGET ALIGNMENT = CENTRELINE OF BARRIER COINCIDENT WITH 'R' POINT

LINE OF VEHICLE \pm 25mm

TARGET VERTICAL ALIGNMENT = \pm 25mm

After Test

9.4 Door Opening Force

9.4.1 Check that none of the doors have locked during the test

9.4.2 Try to open each of the doors on the unstruck side (front door followed by rear door) using a spring-full attached to the external handle. The opening force should be applied perpendicular to the door, in a horizontal plane, unless this is not possible. The manufacturer may specify a reasonable variation in the angle of the applied force. Gradually increase the force on the spring-pull, up to a maximum of 500N, until the door unlatches. If the door does not open record this then try to unlatch the door using the internal handle, again attempt to open the door using the spring-pull attached to the

external handle. Record the forces required to unlatch the door and to open it to 45° in the test details.

- 9.4.3 If a door does not open with a force of 500N then try the adjacent door on the same side of the vehicle. If this door then opens normally, retry the first door.
If the door still does not open, record in the test details whether the door could be opened using extreme hand force or if tools were needed

Note: in the event that sliding doors are fitted, the force required to open the door sufficiently enough for an adult to escape should be recorded in place of the 45° opening force.

9.5 Dummy Removal

- 9.5.1 Do not move the driver seat. Try to remove the dummy.
9.5.2 If the dummy cannot be removed with the seats in its original position, recline the seat back and try again.
9.5.3 If the dummy still cannot be removed, try to slide the seat back on its runners.
9.5.4 If the dummy still cannot be removed, the seat can be cut out of the car.

Where a specified requirement has not been met, ASEAN NCAP reserves the right to decide whether or not the test will be considered as valid.

10 CALCULATION OF INJURY PARAMETERS

The following table lists all of the channels which are to be measured and the Channel Frequency Class at which they are to be filtered. The injury calculation column lists the parameters which will be calculated for each location. If the injury parameter is not a simple peak value and involves some further calculation, details are given subsequently. Head impacts occurring after the dummy head rebounds from an initial contact are not considered when calculating maximum levels of injury parameters. Ringing or other anomalous spikes in the data traces should be removed and peak values/HIC calculated without consideration of the anomaly. A copy of both the original and unmodified traces must always be provided in the data.

ES-2

Location	Parameter	CFC	Injury calculation
Head	Accelerations, $A_x A_y A_z$	1000	HIC Peak acceleration 3msec exceedence (cumulative)
Shoulder	Forces, $F_x F_y F_z$	600	Peak shoulder forces Resultant
Thorax T1	Accelerations, $A_x A_y A_z$	180	Peak lateral acceleration on T1 and T12
Thorax T12	Accelerations, A_y	180	
Ribs – Upper Middle Lower	Accelerations, A_y	180	Viscous Criterion
	Deflection, D_{rib}	180	Peak rib acceleration Peak rib deflection
Abdomen – Front Middle Rear	Forces, F_y	600	Peak of sum of 3 abdomen forces
Backplate	Forces, $F_x F_y$	600	Peak forces and moments
	Moments, $M_y M_z$	600	$F_x F_y$ Resultant
T12	Forces, $F_x F_y$	600	Peak forces and moments
	Moments, $M_x M_y$	600	
Pelvis	Accelerations, $A_x A_y A_z$	180	Peak lateral acceleration
Public Symphysis	Force, F_y	600	Peak force
Femurs (L&R)	Forces, $F_x F_y F_z$	600	Peak forces and moments
	Moments, $M_x M_y M_z$	600	

Q3

Location	Parameter	CFC ³	Injury calculation
Head	Accelerations, A _x A _y A _z	1000	Peak Resultant acceleration Resultant (+ve) 3msec exceedence
Chest	Accelerations, A _x A _y A _z	180	Peak Resultant acceleration Resultant (+ve) 3msec exceedence

Q1½

Location	Parameter	CFC ³	Injury Calculation
Head	Accelerations, A _x A _y A _z	1000	Peak Resultant acceleration Resultant (+ve) 3msec exceedence
Chest	Accelerations, A _x A _y A _z	180	Peak Resultant acceleration Resultant (+ve) 3msec exceedence

Using the above channels, dummy injury parameters can be calculated according to the following procedures:

10.1 Head

10.1.1 Calculate the resultant head acceleration A_R from the three components A_x , A_y and A_z after they have been filtered

$$A_R = \sqrt{A_x^2 + A_y^2 + A_z^2}$$

10.1.2 Calculate the Head Injury Criterion (HIC) according to

$$HIC = (t_2 - t_1) \left[\frac{\int_{t_1}^{t_2} A_R \cdot dt}{(t_2 - t_1)} \right]^{2.5}$$

where A_R is expressed in multiple of g. maximize HIC for any time ‘window’ (t₂ – t₁).

10.1.3 Determine the peak acceleration level of A_R and the level it exceeds for a cumulative time period of three milliseconds i.e. the head 3msec exceedence.

10.2 Ribs

- 10.2.1 Determine the greatest value of the rib deflection D_{rib} for all three ribs.
- 10.2.2 Calculate the Viscous Criterion according to the equation.

$$\text{Viscous Criterion} = V * C$$

$D_{(t)}$ is the instantaneous rib deflection at any time t . $C_{(t)}$ is the compression, related to the rib deflection $D_{(t)}$

$$C_{(t)} = \frac{D_{(t)}}{0.140}$$

V is the velocity of deflection and is calculated as the differential of the deflection with respect to time:

$$V_{(t)} = \frac{8 * [D_{(t+1)} - D_{(t-1)}] - [D_{(t+2)} - D_{(t-2)}]}{12\delta t}$$

where δt is the time interval between successive digital samples of $D_{(t)}$. Calculate $V * C$ continuously with time and determine its greatest value.

10.3 Abdomen

- 10.3.1 Find the sum of the three abdomen force transducers as a function of time after the individual components have been filtered.
- 10.3.2 Determine the maximum value of the total abdominal force.

10.4 Pelvis

- 10.4.1 Determine the peak lateral acceleration of the pelvis.

10.5 Pubic Symphysis

- 10.5.1 Determine the peak value of the lateral force measured on the public symphysis.

10.6 Child Dummies

- 10.6.1 For the Q3 and Q1½ dummies, calculate the resultant head and chest acceleration A_R from the three components A_x , A_y and A_z after they have been filtered and determine the maximum value of A_R .

$$A_R = \sqrt{A_x^2 + A_y^2 + A_z^2}$$

- 10.6.2 For the Q3 and Q1½ dummies, determine the level which head resultant acceleration ($+A_R$) exceeds for a cumulative time of three milliseconds.

Appendix I

Impactor Specifications

1 IMPACTOR SPECIFICATIONS

Below is excerpt from document TRANS/WP.29/904, which is an amendment to Annex 5 of Regulation ECE R95. For further details refer to R95, note the section headings used are those used in R95.

2 CHARACTERISTIC OF THE IMPACTOR

The impactor consists of single blocks of aluminium honeycomb, which has been processed in order to give a progressively increasing level of force with increasing deflection (see paragraph 2.1.). Front and rear aluminium plates are attached to the aluminium honeycomb blocks.

2.1 Honeycomb Blocks

2.1.1 Geometrical characteristics

2.1.1.1 The impactor consists of 6 joined zones whose forms and positioning are shown in figure 1 and 2. The zones are defined as 500 ± 5 mm x 3 mm in figure 1 and 2. The 500 mm should be in the W direction and the 250 mm in the L direction of the aluminium honeycomb construction (see figure 3).

2.1.1.2 The impactor is divided into two rows. The lower row shall be 250 ± 3 mm high, and 500 ± 2 mm deep after pre-crush (see paragraph 2.1.2.), and deeper than the upper row by 60 ± 2 mm.

2.1.1.3 The blocks must be centred on the six zones defined in figure 1 and each block (including incomplete cells) should cover completely the area defined of each zones).

2.1.2 Pre-crush

2.1.2.1 The pre-crush shall be performed on the surface of the honeycomb to which the front sheets are attached.

2.1.2.2 Blocks 1, 2 and 3 should be crushed by 10 ± 2 mm on the top surface prior to testing to give a depth of 500 ± 2 mm (figure 2).

2.1.2.3 Blocks 4, 5 and 6 should be crushed by 10 ± 2 mm on the top surface prior to testing to give a depth of 440 ± 2 mm.

2.1.3 Material characteristics

2.1.3.1 The cell dimensions shall be $19 \text{ mm} \pm 10$ per cent for each block (see figure 4).

2.1.3.2 The cells must be made of 3003 aluminium for the upper row.

2.1.3.3 The cells must be made of 5052 aluminium for the lower row.

2.1.3.4 The aluminium honeycomb blocks should be processed such that the force deflection-curve when statistically crushed (according to the procedure defined in paragraph 2.1.4.) is within the corridors defined for each of the six blocks in appendix 1 to this annex. Moreover, the processed honeycomb material used in the honeycomb blocks to be used for constructing the barrier, should be cleaned in order to remove any residue that may

have been produced during the processing of the raw honeycomb material.

2.1.3.5 The mass of the blocks in each batch shall not differ by more than 5 percent of the mean block mass for that batch.

2.1.4 Static tests

2.1.4.1 A sample taken from each batch of processed honeycomb core shall be tested according to the static test procedure described in paragraph 5.

2.1.4.2 The force-compression for each block tested shall lie within the force deflection corridors defined in appendix 1. Static force- deflection corridors are defined for each block of the barrier.

2.1.5 Dynamic test

2.1.5.1 The dynamic deformation characteristics, when impacted according to the protocol described in paragraph 6.

2.1.5.2 Deviations from the limits of the force-deflection corridors characterising the rigidity of the impactor – as defined in appendix 2 – may be allowed provided that:

2.1.5.2.1 The deviations occurs after the beginning of the impact and before the deformation of the impactor is equal to 150 mm;

2.1.5.2.2 The deviation does not exceed 50 percent of the nearest instantaneous prescribed limit of the corridor;

2.1.5.2.3 Each deflection corresponding to each deviation does not exceed 35 mm of deflection, and the sum of these deflections does not exceed 70 mm (see appendix 2 to this annex);

2.1.5.2.4 The sum of energy derived from deviating outside the corridors does not exceed 5 percent of the gross energy for that block.

2.1.5.3 Blocks 1 and 3 are identical. Their rigidity is such that their force deflection curves fall between corridors of figure 2a.

2.1.5.4 Blocks 5 and 6 are identical. Their rigidity is such that their force deflection curves fall between corridors of figure 2d.

2.1.5.5 The rigidity of block 2 is such that its force deflection curves fall between corridors of figure 2b.

2.1.5.6 The rigidity of block 4 is such that its force deflection curves fall between corridors of figure 2c.

2.1.5.7 The force-deflection of the impactor as a whole shall fall between corridors of figure 2e.

2.1.5.8 The force-deflection curves shall be verified by a test detailed in annex 5, paragraph 6, consisting of an impact of the barrier against a dynamometric wall at 35 ± 0.5 km/h.

- 2.1.5.9 The dissipated energy 1/ against blocks 1 and 3 during the test shall be equal to 9.5 ± 2 kJ for these blocks.
- 2.1.5.10 The dissipated energy against blocks 5 and 6 during the test shall be equal to 3.5 ± 1 kJ for these blocks.
- 2.1.5.11 The dissipated energy against block 4 shall be equal to 4 ± 1 kJ.
- 2.1.5.12 The dissipated energy against block 2 shall be equal to 15 ± 2 kJ.
- 2.1.5.13 The dissipated total energy during the impact shall be equal to 45 ± 3 kJ.
- 2.1.5.14 The maximum impactor deformation from the point of first contact, calculated from integration of the accelerometers according to paragraph 6.6.3. , shall be equal to 330 ± 20 mm.
- 2.1.5.15 The final residual static impactor deformation measured after the dynamic test at level B (figure 2) shall be equal to 310 ± 20 mm.

2.2 Front plates

2.2.1 Geometrical characteristics

- 2.2.1.1 The front plates are $1,500 \pm 1$ mm wide and 250 ± 1 mm high . The thickness is 0.5 ± 0.06 mm.
- 2.2.1.2 When assembled the overall dimensions of the impactor (defined in figure 2) shall be: 1500 ± 2.5 mm wide and 500 ± 2.5 mm high.
- 2.2.1.3 The upper edge of the lower front plate and the lower edge of the upper front plate should be aligned within 4 mm.

2.2.2 Material characteristics

- 2.2.2.1 The front plates are manufactured from aluminium of series AlMg₂ to AlMg₃ with elongation ≥ 12 per cent, and a UTS ≥ 175 N/mm².

2.3 Back plate

2.3.1 Geometric characteristics

- 2.3.1.1 The geometric characteristics shall be according to figure 5 and figure 6.

2.3.2 Material characteristics

2.3.2.1 The back plate shall consist of a 3 mm aluminium sheet. The back plate shall be manufactured from aluminium of series AlMg₂ to AlMg₃ with a hardness between 50 and 65 HBS. This plate shall be perforated with holes for ventilation: the location, the diameter and pitch are shown in figure 5 and 7.

2.4 **Location of the honeycomb blocks**

2.4.1 The honeycomb block shall be centred on the perforated zone of the 1. The amounts of energy indicated are the amounts of energy dissipated by the system when the extent to which the impactor is crushed is greatest.

Back plate (figure 5)

2.5 **Bonding**

2.5.1 For both the front and the back plates, a maximum of 0.5 kg/m² shall be applied evenly over the surface of the front plate, giving a maximum film thickness of 0.5 mm. The adhesive to be used throughout should be a two-part polyurethane {such as Ciba Geigy XB5090/1 resin with XB5304 hardener} or equivalent.

2.5.2 For the back plate the minimum bonding strength shall be 0.6 MPa, (87 psi), tested according to paragraph 2.4.3.

2.5.3 Bonding strength tests:

2.5.3.1 Flatwise tensile testing is used to measure bond strength of adhesive according to ASTM C297-61.

2.5.3.2 The test piece should be 100 mm x 100 mm, and 15 mm deep, bonded to a sample of the ventilated back plate material. The honeycomb used should be representative of that in the impactor, i.e. chemically etched to an equivalent degree as that near to the back plate in the barrier but without pre-crushing.

2.6 **Traceability**

2.6.1 Impactors shall carry consecutive serial numbers which are stamped, etched or otherwise permanently attached, from which the batches for the individual blocks and the date of manufacture can be established.

2.7 **Impactor attachment**

2.7.1 The fitting on the trolley must be according to figure 8. The fitting will use six M8 bolts, and nothing shall be larger than the dimensions of the barrier in front of the wheels of the trolley. Appropriate spacers must be used between the lower back plate flange and the

trolley face to avoid bowing of the back plate when the attachment bolts are tightened.

3 VENTILATION SYSTEM

3.1 The interface between the trolley and the ventilation system should be solid, rigid and flat. The ventilation device is part of the trolley and not of the impactor as supplied by the manufacturer. Geometrical characteristics of the ventilation device shall be according to figure 9.

3.2 Ventilation device mounting procedure

3.2.1 Mount the ventilation device to the front plate of the trolley;

3.2.2 Ensure that a 0.5 mm thick gauge cannot be inserted between the ventilation device and the trolley face at any point. If there is a gap greater than 0.5 mm, the ventilation frame will need to be replaced or adjusted to fit without a gap of > 0.5 mm.

3.2.3 Dismount the ventilation device from the front of the trolley;

3.2.4 Fix a 1.0 mm thick layer of a cork to the front face of the trolley;

3.2.5 Re-mount the ventilation device to the front of the trolley and tighten to exclude the air gaps.

4 CONFORMITY OF PRODUCTION

The conformity of production procedures shall comply with those set out in the Agreement, Appendix 2 (E/ECE/324-E/ECE/TRANS/505/Rev.2), with the following requirements:

4.1 The manufacturer shall be responsible for the conformity of production procedures and for that purpose must in particular:

4.1.1 Ensure the existence of effective procedures so that the quality of the products can be inspected,

4.1.2 Have access to the testing equipment needed to inspect the conformity of each product,

4.1.3 Ensure that the test results are recorded and that the documents remain available for a time period of 10 years after the tests,

4.1.4 Demonstrate that the samples tested are reliable measure of the performance of the batch (examples of sampling methods according to batch production are given below).

4.1.5 Analyse results of tests in order to verify and ensure the stability of the barrier characteristics, making allowance for variations of an industrial production, such as temperature, raw materials quality, time of immersion in chemical, chemical

concentration, neutralisation etc, and the control of the processed material in order to remove any residue from the processing,

4.1.6 Ensure that any set of samples or test pieces giving evidence of non-conformity gives rise to a further sampling and test. All the necessary steps must be taken to restore conformity of the corresponding production.

4.2 The manufacturer's level of certification must be at least ISO 9002 standard.

4.3 Minimum conditions for the control of production: the holder of an agreement will ensure the control of conformity following the methods hereunder described.

4.4 Example of sampling according to batch

4.4.1 If several example of one block type are constructed from one original block of aluminium honeycomb and are all treated in the same treatment bath (parallel production), one of these examples could be chosen as the sample, provided care is taken to ensure that the treatment is evenly applied to all blocks. If not, it may be necessary to select more than one sample.

4.4.2 If a limited number of similar blocks (say three to twenty) are treated in the same bath (serial production), then the first and last block treated in a batch, all of which are constructed from the same original block of aluminium honeycomb, should be taken as representative samples. If the first sample complies with the requirements but the last does not, it may be necessary to take further samples from earlier in the production until a sample that does comply is found. Only the blocks between these samples should be considered to the approved.

4.4.3 Once experience is gained with the consistency of production control, it may be possible to combine both sampling approaches, so that more than one groups of parallel production can be considered to be a batch provided samples from the first and last production groups comply.

5 STATIC TESTS

5.1 One or more samples (according to the batch method) taken from each batch of processed honeycomb core shall be tested, according to the following test procedure:

5.2 The sample size of the aluminium honeycomb for static tests shall be the size of a normal block of the impactor, that is to say 250 mm x 500 mm x 440 mm for top row and 250 mm x 500 mm x 500 mm for the bottom row.

5.3 The samples should be compressed between two parallel loading plates which are at least

20 mm larger than the block cross section.

- 5.4 The compression speed shall be 100 mm per minute, with a tolerance of 5 per cent.
- 5.5 The data acquisition for static compression shall be sampled at a minimum of 5 Hz.
- 5.6 The static test shall be continued until the block compression is at least 300 mm for blocks 4 to 6 and 350 mm for blocks 1 to 3.

6 DYNAMIC TESTS

For every 100 barrier faces produced, the manufacturer shall make one dynamic test against a dynamometric wall supported by a fixed rigid barrier, according to the method described below.

6.1 Installation

6.1.1 Testing ground

6.1.1.1 The test area shall be large enough to accommodate the run-up-track of the mobile deformable barrier, the rigid barrier and the technical equipment necessary for the test. The last part of the track, for at least 5 metres before the rigid barrier, shall be horizontal, flat and smooth.

6.1.2 Fixed rigid barrier and dynamometric wall

6.1.2.1 The rigid wall shall consist of a block of reinforced concrete not less than 3 metres wide and not less than 1.5 metres high. The thickness of the rigid wall shall be such that it weighs at least 70 tonnes.

6.1.2.2 The front face shall be vertical, perpendicular to the axis of the run-up-track and equipped with six load cell plates, each capable of measuring the total load on the appropriate block of the mobile deformable barrier impactor at the moment of impact. The load cell impact plate area centres shall align with those of the six impact zones of the mobile deformable barrier face. Their edges shall clear adjacent areas by 20 mm such that, within the tolerance of impact alignment of the MDB, the impact zone will not contact the adjacent impact plate areas. Cell mounting and plate surfaces shall be in accordance with the requirements set out in the annex to standard ISO 6487:1987.

6.1.2.3 Surface protection, comprising a plywood face (thickness: 12 ± 1 mm), is added to each load cell plate such that it shall not degrade the transducer responses.

6.1.2.4 The rigid wall shall be either anchored in the ground or placed on the ground with, if necessary, additional arresting devices to limit its deflection. A rigid wall (to which the load cells are attached) having different characteristics but giving results that are at least equally conclusive may be used.

6.2 Propulsion of the mobile deformable barrier

At the moment of the impact of mobile deformable barrier shall no longer be subject to the action of any additional steering or propelling device. It shall reach the obstacle on a course perpendicular to the front surface of the dynamometric wall. Impact alignment shall be accurate to within 10 mm.

6.3 Measuring instrument

6.3.1 Speed

The impact speed shall be 35 ± 0.5 km/h the instrument used to record the speed on impact shall be accurate to within 0.1 percent.

6.3.2 Loads

Measuring instrument shall meet the specifications set forth in ISO 6487:1987

CFC for all blocks	:	60 Hz
CAC for blocks 1 and 3	:	200 kN
CAC for blocks 4,5 and 6	:	100 kN
CAC for block 2	:	200 kN

6.3.3 Acceleration

6.3.3.1 The acceleration in the longitudinal direction shall be measured at three separate positions on the trolley, one centrally and one at each side, at places not subject to bending.

6.3.3.2 The central accelerometer shall be located within 500 mm of the location of the centre of gravity of the MDB and shall lie in a vertical longitudinal plane which is within ± 10 mm of the centre of gravity of the MDB.

6.3.3.3 The side accelerometers shall be at the same height as each other ± 10 mm and at the same distance from the front surface of the MDB ± 20 mm.

6.3.3.4 The instrumentation shall comply with ISO 6487:1987 with the following specifications:

CFC 1,000 Hz (before integration)
CAC 50 g

6.4 General specification of the barrier

6.4.1 The individual characteristics of each barrier shall comply with paragraph 1 of this annex and shall be recorded.

6.5 General specification of the impactor

6.5.1 The suitability of an impactor as regards the dynamic test requirements shall be confirmed when the outputs from the six load cell plates each produce signals complying with the requirements indicated in this annex.

6.5.2 Impactors shall carry consecutive serial numbers which are stamped, etched or otherwise permanently attached, from which the batches for the individual blocks and the date of manufacture can be established.

6.6 Data processing procedure

6.6.1 Raw data: At time $T = T_0$, all offsets should be removed from the data. The method by which offsets are removed shall be recorded in the test report.

6.6.2 Filtering

6.6.2.1 The raw data will be filtered prior to processing/calculations.

6.6.2.2 Accelerometer data for integration will be filtered to CFC 180, ISO 6487:1987.

6.6.2.3 Accelerometer data for impulse calculations will be filtered to CFC 60, ISO 6487:1987.

6.6.2.4 Load cell data will be filtered to CFC 60, ISO 6487:1987.

6.6.3 Calculation of MDB face deflection

6.6.3.1 Accelerometer data from all three accelerometers individually (after filtering at CFC 180), will be integrated twice to obtain deflection of the barrier deformable element.

6.6.3.2 The initial conditions for deflection are:

6.6.3.2.1 Velocity = impact velocity (from speed measuring device).

6.6.3.2.2 Deflection = 0

6.6.3.3 The deflection at the left hand side, mid-line and right hand side of the mobile deformable barrier will be plotted with respect to time.

6.6.3.4 The maximum deflection calculated from each of the three accelerometers should be within 10 mm. If it is not the case, then the outlier should be removed and difference between the deflections calculated from the remaining two accelerometers checked to ensure that it is within 10 mm.

6.6.3.5 If the deflections as measured by the left hand side, right hand side and mid-line accelerometers are within 10 mm, then the mean acceleration of the three accelerometers should be used to calculate the deflection of the barrier face.

6.6.3.6 If the deflection from only two accelerometers meets the 10 mm requirement, then the mean acceleration from these two accelerometers should be used to calculate the deflection for the barrier face.

6.6.3.7 If the deflections calculated from all three accelerometers (left hand side, right hand side and mid-line) are NOT within 10 mm requirement, then the raw data should be reviewed to determine the causes of such large variation. In this case the individual test house will determine which accelerometer data should be used to determine mobile deformable barrier deflection or whether none of the accelerometer readings can be used, in which case, the certification test must be repeated. A full explanation should be given in the test report.

6.6.3.8 The mean-deflection time data will be combined with the load cell wall force-time data to generate the force-deflection result for each block.

6.6.4 Calculation of energy

The absorbed energy for each block and for the whole MDB face should be calculated up to the point of peak deflection of the barrier.

$$E_n = \int_{t_0}^{t_1} F_n \cdot ds_{mean}$$

where:

- t_0 is the time of first contact
- t_1 is the time where the trolley comes to rest, i.e. where $u = 0$
- s is the deflection of the trolley deformable element calculated according to paragraph 6.6.3.

6.6.5 Verification of dynamic force data

6.6.5.1 Compare the total impulse, I, calculated from the integration of the total force over the period of contact, with the momentum change over that period (M^*V).

6.6.5.2 Compare the total energy change to the change in kinetic energy of the MDB, given by:

$$E_k = \frac{1}{2} MV_i^2$$

Where V_i is the impact velocity and M the whole mass of the MDB

If the momentum change (M^*V) is not equal to the total impulse (I) ± 5 per cent, or if the total energy absorbed ($E E_n$) is not equal to the kinetic energy, $E_x \pm 5$ per cent, then the test data must be examined to determine the cause of this error.

DESIGN OF IMPACTOR 2/

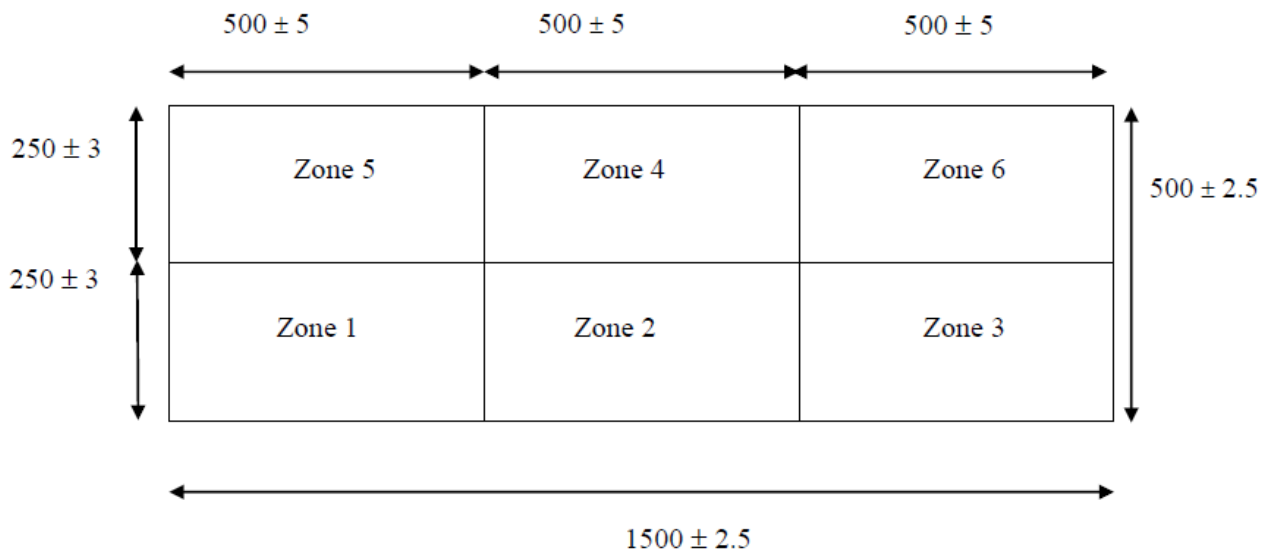

Figure 1

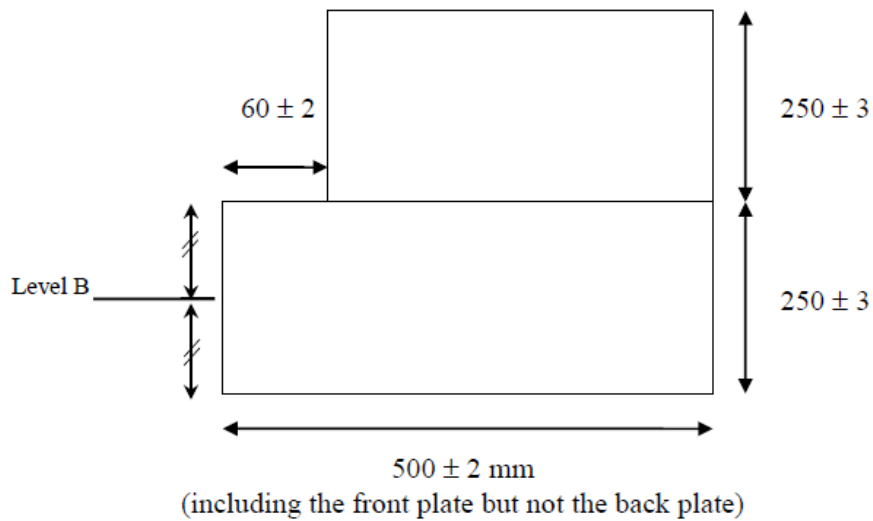

Figure 2

2/ All dimensions are in mm. The tolerances on the dimensions of the blocks allow for the difficulties of measuring cut aluminium honeycomb. The tolerance on the overall dimension of the impactor is less than that for the individual

blocks since the honeycomb blocks can be adjusted, with overlap if necessary, to maintain a more closely defined impact face dimension.

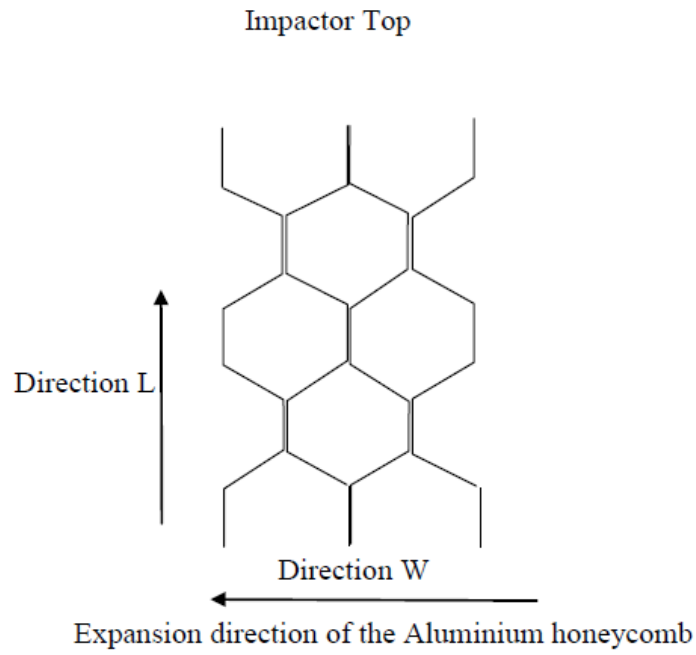

Figure 3 - Aluminium Honeycomb Orientation

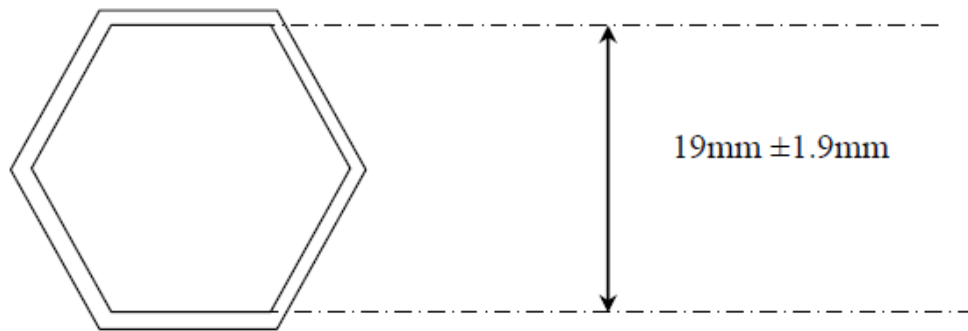

Figure 4 - Dimension of Aluminium Honeycomb Cells

DESIGN OF THE BACK PLATE

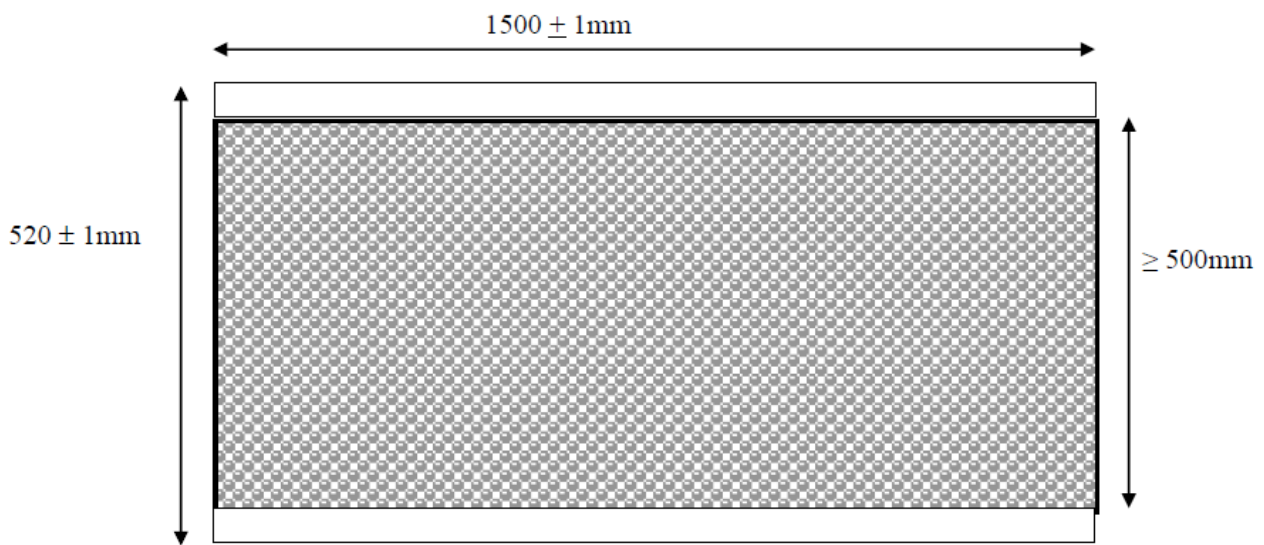

Figure 5 - Front View

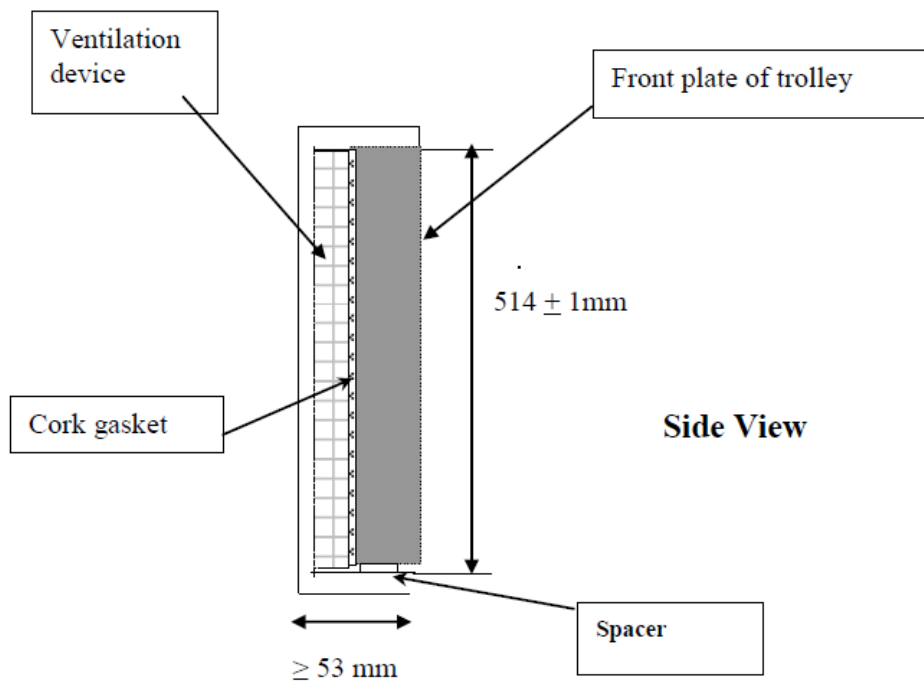

Figure 6 - Attachment of backplate to ventilation device and trolley face plate

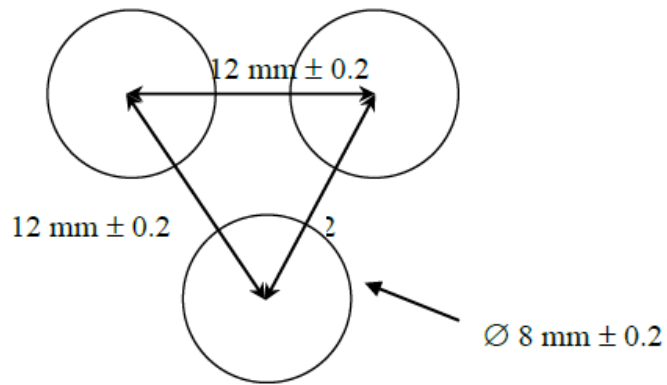
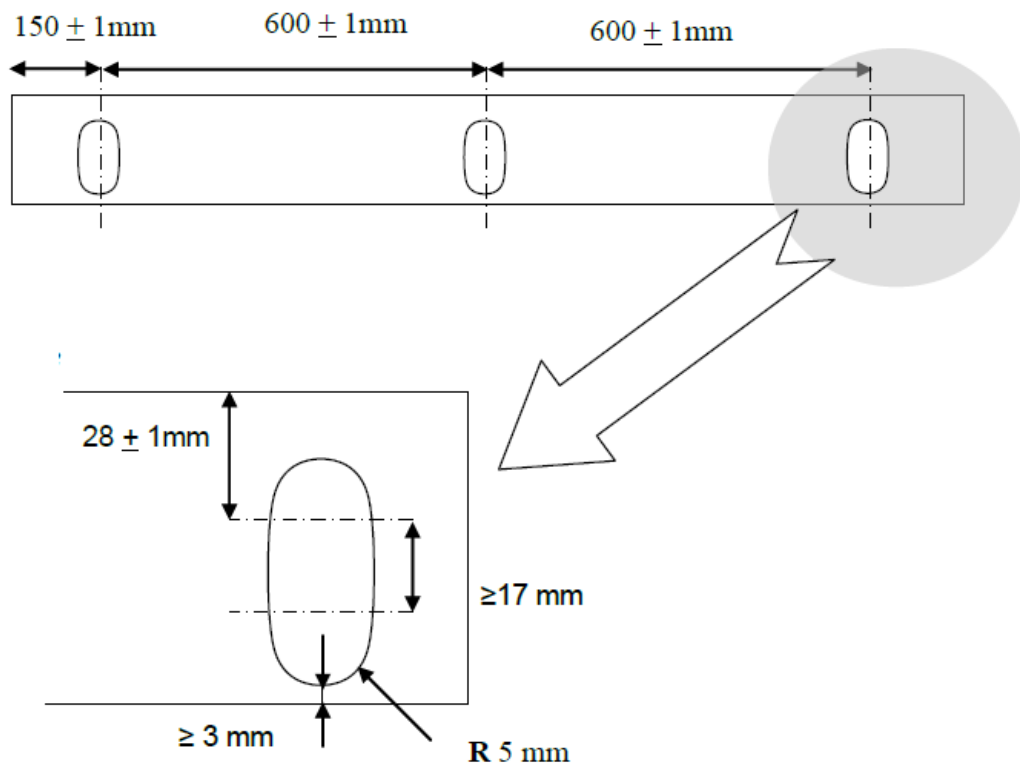

Figure 7 - Staggered pitch for the back plate ventilation holes



Top and bottom back plate flanges

Note: The attachment holes in the bottom flange may be opened to slots, as shown below, for ease of attachment provided sufficient grip can be developed to avoid detachment during the whole impact test.

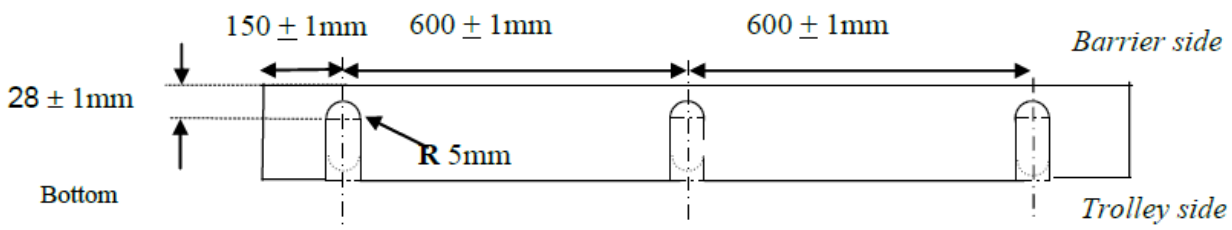
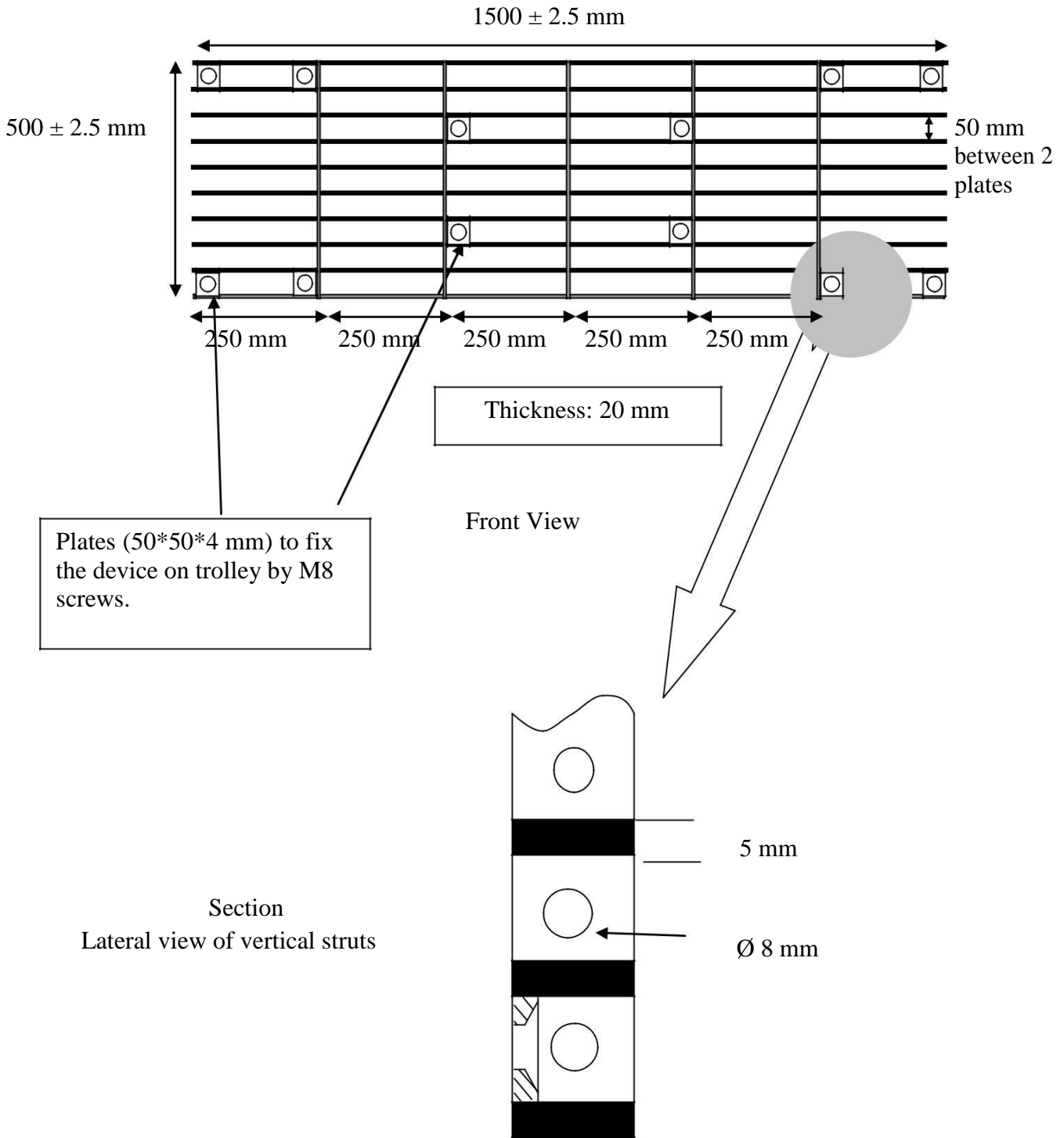

Figure 8

VENTILATION FRAME

The ventilation device is a structure made of a plate that is 5 mm thick and 20 mm wide. Only the vertical plates are perforated with nine 8 mm holes in order to let air circulate horizontally.



Side View
Figure 9

Annex 5, Appendices 1 and 2, amend to read:

Annex 5 - Appendix 1

FORCE-DEFLECTION CURVES FOR STATIC TESTS

Blocks 1 & 3

Figure 1a

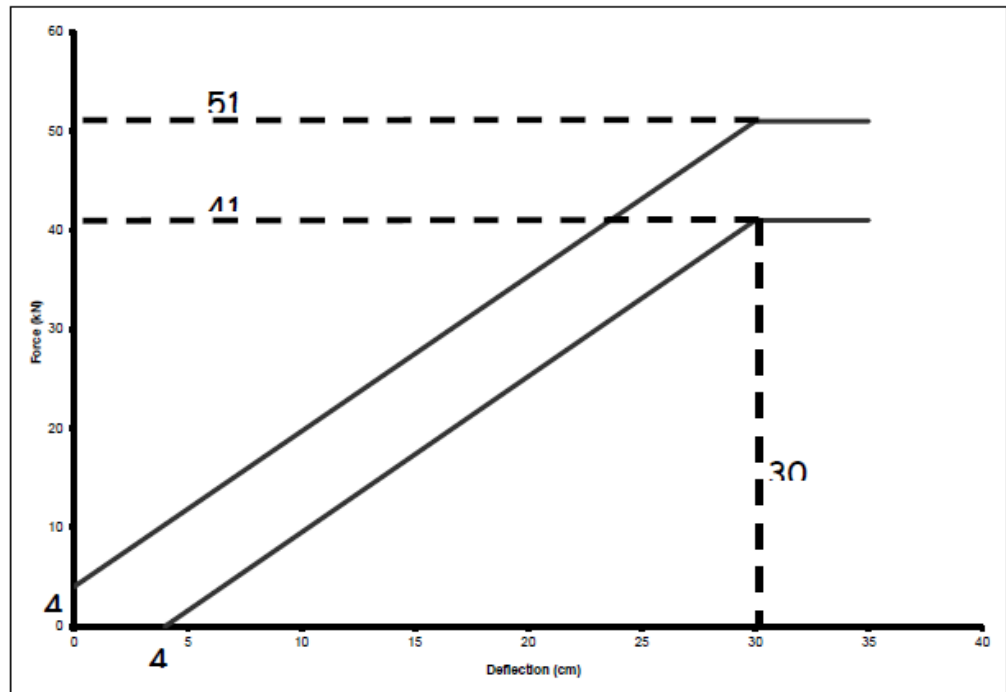

Block 2

Figure 1b

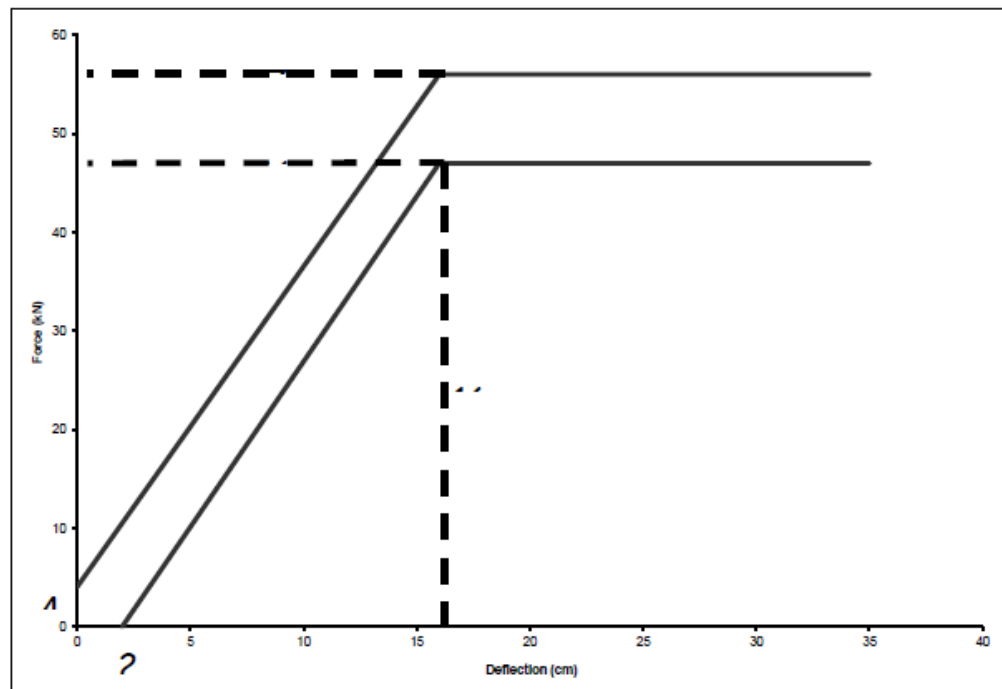

Block 4

Figure 1c

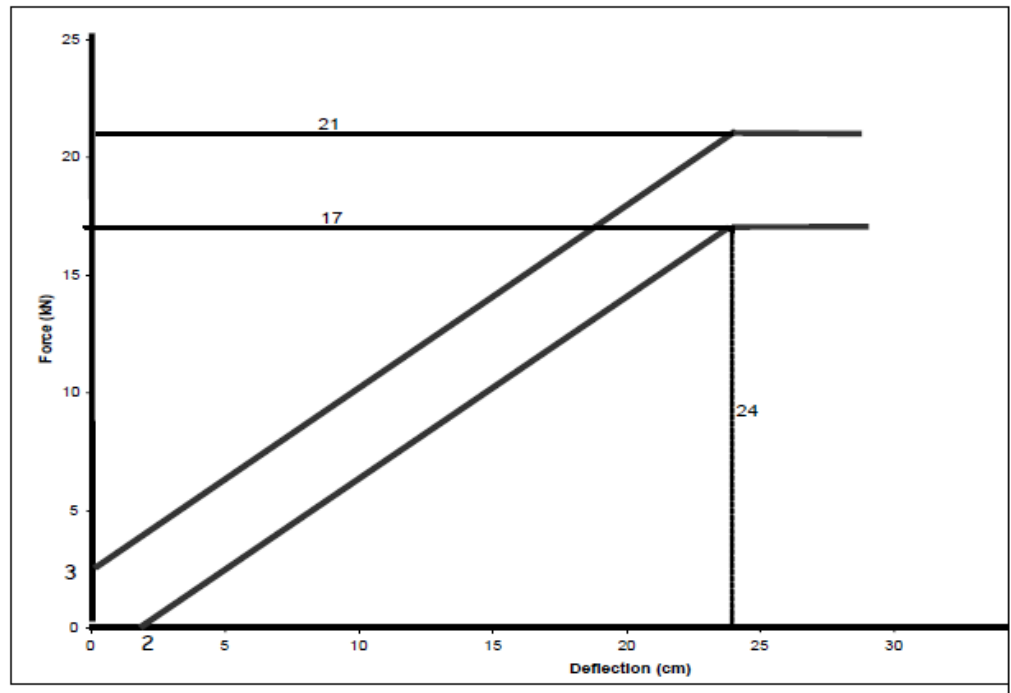

Blocks 5 & 6

Figure 1d

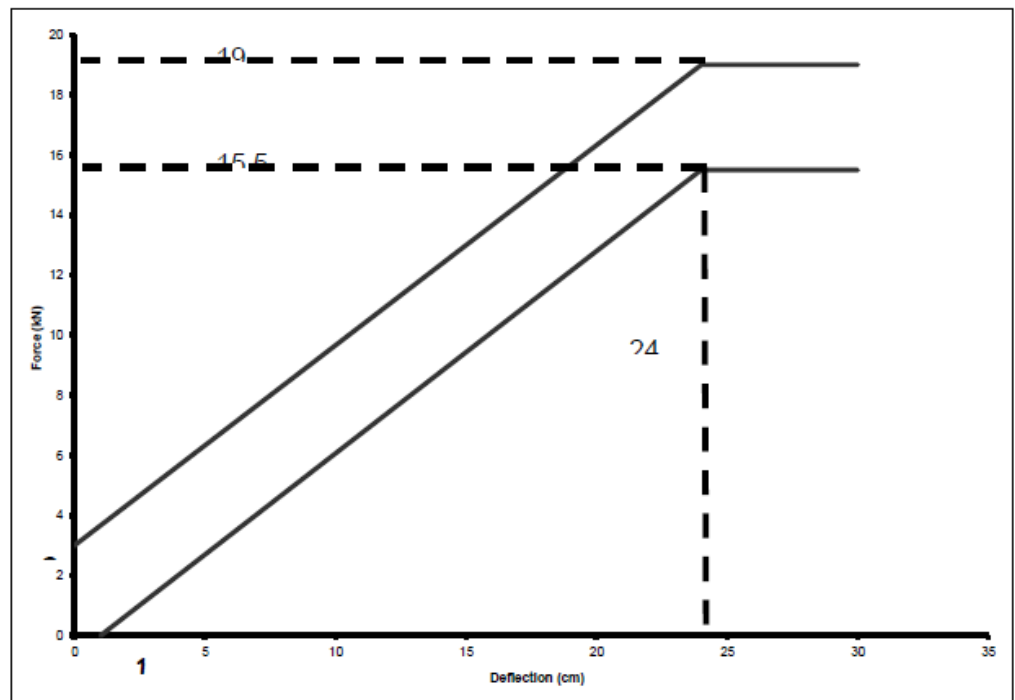

Annex 5 - Appendix 2

FORCE-DEFLECTION CURVES FOR DYNAMIC TESTS

Blocks 1 & 3

Figure 2a

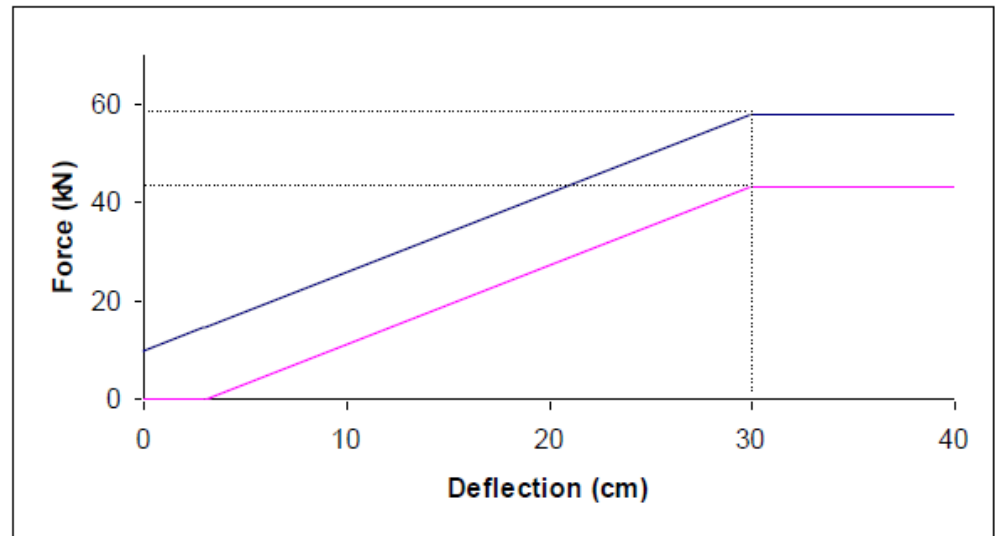

Block 2

Figure 2b

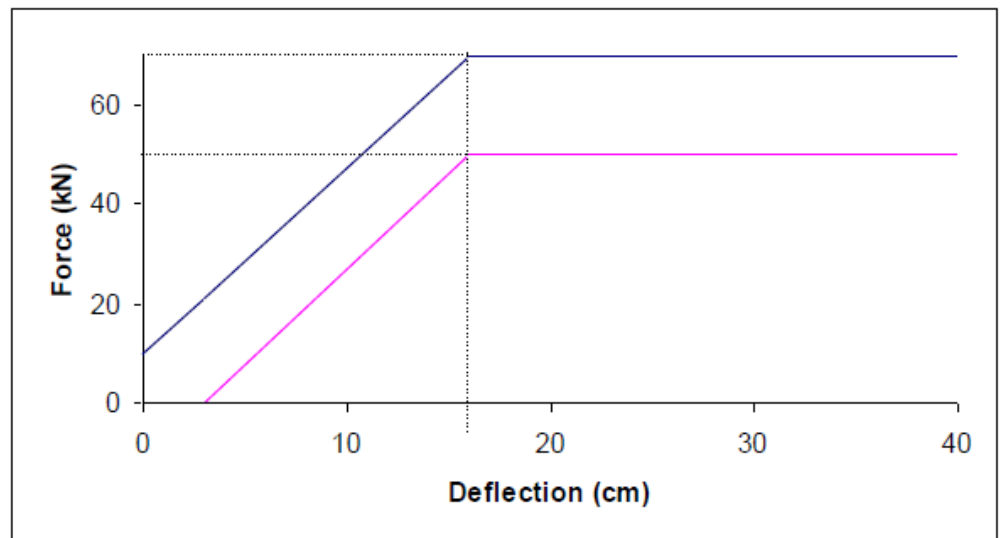

Block 4

Figure 2c

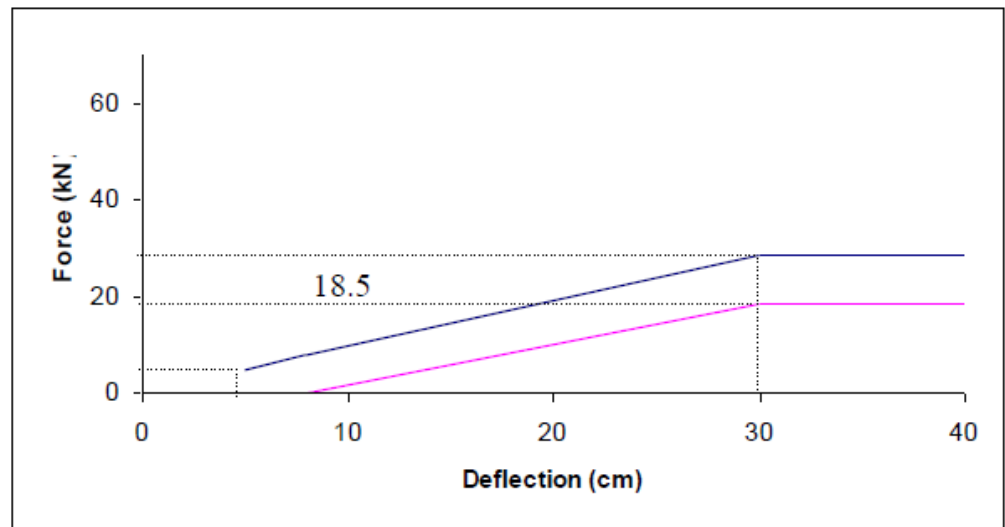

Blocks 5 & 6

Figure 2d

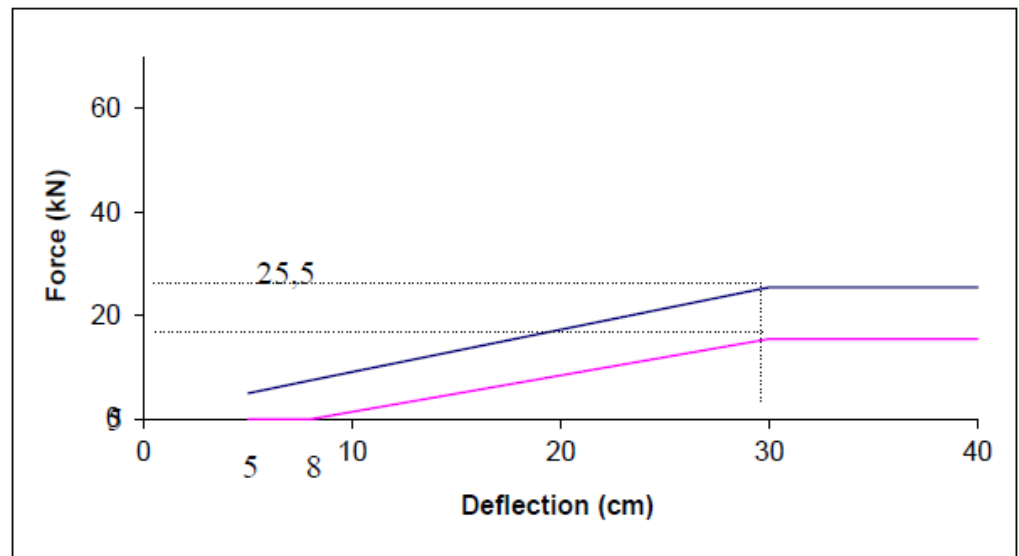

Blocks total

Figure 2e

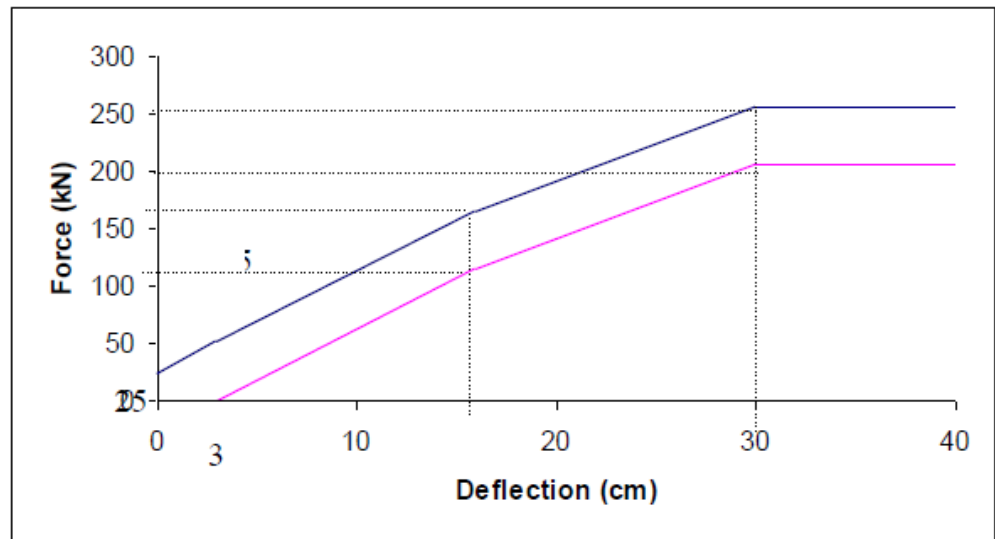

Side View

ASEAN NCAP Technical Committee

Mohd Hafzi Md Isa
Malaysian Institute of Road Safety Research (MIROS)

Khairil Anwar Abu Kassim
Malaysian Institute of Road Safety Research (MIROS)

Yahaya Ahmad
Malaysian Institute of Road Safety Research (MIROS)

Assoc. Prof. Dr. Saiprasit Koetnuyom
The Sirindhorn International Thai-German Graduate School of
Engineering (TGGS)

Assoc. Prof. Dr. Julaluk Charmai
The Sirindhorn International Thai-German Graduate School of
Engineering (TGGS)

Dr. Ir. Sigit P. Santosa
Institut Teknologi Bandung (ITB)

Dr. Ly Hung Anh
Ho Chi Minh City University of Technology (HCMUT)

Dr. Atsuhiko Konosu
Japan Automobile Research Institute (JARI)

Salina Mustaffa
Malaysian Institute of Road Safety Research (MIROS)

Special Acknowledgement:

This protocol is based on Euro NCAP Side Impact Testing Protocol Version 6.0 which is the intellectual property of Euro NCAP. Permission is granted for this material to be shared for non-commercial and educational purposes. Copying of parts of the original text is by permission of Euro NCAP.



ASEAN NCAP

Ground Floor, Lot 127,
Jalan TKS 1,
Taman Kajang Sentral,
43000 Kajang,
Selangor, Malaysia.



+603-8924 9200 (ext. 425)



+603-8733 2005



enquiries@aseancap.org



www.aseancap.org